

FORESPAR[®] MARELON[®]

ENGINE FLUSH OUT INSTALLATION

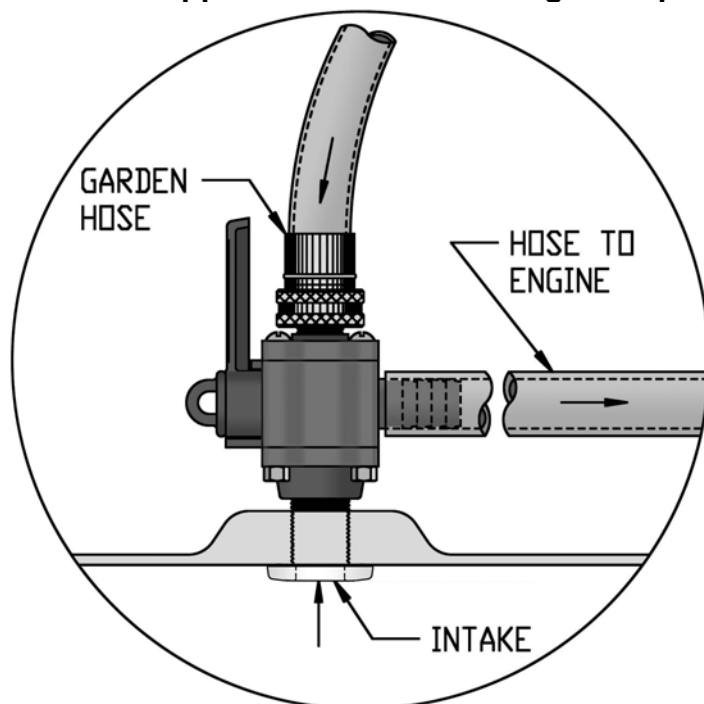

With the Marelon Engine Flush Out Valve system, all it takes is a garden hose and the throw of a handle to run fresh water or anti-freeze through your inboard engine. The “Y” valve is built into the U.L. approved seacock making this operation a breeze.

Regular fresh water flushing will extend the life of your engine’s cooling system. Now you can winterize easier and flush your engine regularly without the cumbersome changing of hoses, using pumps, or other equipment. This Marelon system makes it simple and fast.

- Marelon seacock attaches to your existing thru-hull Marelon or bronze
- Simple re-routing of engine intake hose to valve barb
- Available in 1”, 1-1/4”, 1-1/2”, and 2” hose sizes
- Marine U.L. approved valve
- Makes engine winterizing easier, faster
- For any inboard engine on power or sailboats

INSTRUCTIONS

- Hard plumb your engine to the horizontal barb (shown on the next page, on the right side of the valve) and then set your garden hose to the top connection.
- Throw the handle and you’re ready to flush.

It’s that simple!

Forespar[®]

22322 Gilberto Rancho Santa Margarita, CA. 92688

Ph: 949-858-8820 Fax: 949-858-0505

www.forespar.com

sales@forespar.com

www.facebook.com/foresparsailing

www.twitter.com/foresparsailing

FORESPAR[®] **MARELON[®]**

ENGINE FLUSH OUT INSTALLATION

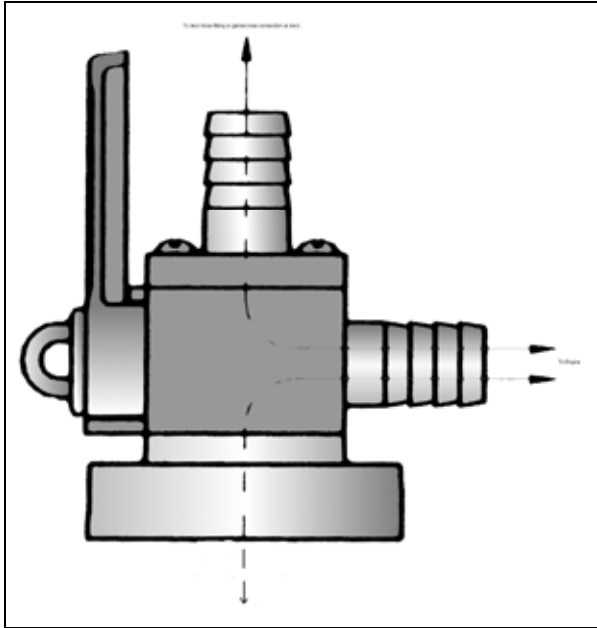

Flush out valve with hose barb top



Flush out valve with garden hose top