

FORESPAR[®] TECH-TIP

MF-850 Marelon[®] Ball Valve Installation

Trouble shooting

All Marelon[®] ball valves (MF 850 series) have two “hex” nuts molded into them, one at the top (part of the body of the valve) and one on the bottom (the “King” nut). The “King” nut is a separate part that screws into the body and holds the lower set of ball seals. This “King” nut is the last part to go on the valve during assembly. The valves seals pressure is then “tuned” by screwing this king nut down until the seal pressure is sufficient to stop water leaking past them and still allow the handle stem turn with reasonable force. This pressure is set at the factory to the U.L. standard.

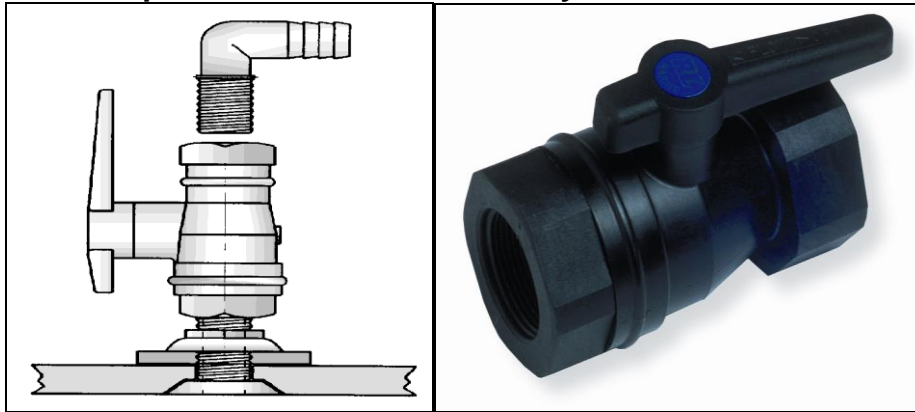

If the valve is installed on the through hull by using a wrench on the top hex nut, the installer can increase the “King” nut pressure on the valve’s seals. This will make the handle turn stiff, or seize the valve completely. The problem may not become apparent immediately but the increased stiffness of the handle’s operation can cause the handle stem to shear as more force than designed is now required to move the ball.

To properly install the MF 850 style ball valves, never use a wrench on the top hex. Always apply the wrench to the bottom hex “King” nut to screw the valve onto the through hull. The top hex is there only to hold the body while installing the tailpipe or elbow barbed fitting on the top.

If you have a stiff moving handle on a MF 850 valve installed on a boat, you may be able to ease the required handle force by holding the bottom “King” nut with a wrench, then, using a second wrench on the top hex, backing off (counter-clockwise) the body a bit. It doesn’t take very much of a turn to change the seal pressure. **Caution!** If you back it off too far, the valve will leak around the “King” nut to body joint.

Remember to activate the handles regularly and lubricate the valves during haul-outs. When in the water, the valves can be closed, hoses removed, and the valve lubricated by using a soda straw and winch grease, water pump grease or silicone lubes. Do not use any aerosol or “penetrating” lubricants (such as WD-40) as these may attack the Marelon[®] or the seals (or both) and cause them to swell and seize. We recommend using Forespar’s MareLube Valve Lubricant, which is available at your local marine supply store or at <https://www.forespar.com/marelube/>