



**FORESPAR<sup>®</sup>**  
**MARINE PRODUCTS THAT PERFORM**



• *Sail Handling Equipment*

• *Masts, Booms & Spars*

• *Custom Accessories*

• *Safety Equipment*

• *Sailing Hardware*

• *Composites*



**FORESPAR<sup>®</sup>**  
**SAILBOAT HARDWARE**

**2007-08**

# Forespar® Overseas Agents and Dealer Literature

## AUSTRALIA

DECKHARDWARE AUSTRALASIA  
PTY LIMITED  
6/224 Headland Road  
Dee Why, New South Wales 2099  
Australia  
Ph: (61) 02-9905-9400  
Fax: (61) 02-9905-9455  
Email: info@deckhardware.com.au

## AUSTRIA

ALLTECKNIK-ALLROUNDMARIN  
Griesfeldstrasse 1  
A-2351 Wiener Neudorf  
Austria  
Ph: (43) 02236-64676  
Fax: (43) 02236-63135

## BRAZIL

REGATTA  
R. Alvarenga, 2121  
Butanta, Sao Paulo-SP  
Brazil  
Ph: (55) 1130303400  
Fax: (55) 1138147015

## CARIBBEAN

FKG MARINE RIGGING  
Box 5011 Phillipsburg  
37 Wellington Rd, Cole Bay  
St. Maarten, Netherland Antilles  
Ph: (5995) 44732  
Fax: (5995) 42171  
Email: Kevin@fkg-marine-rigging.com

BUDGET MARINE - N.A. (Main Office)  
25 B Waterfront Rd, Cole Bay  
St. Maarten, Netherland Antilles  
Ph: (599) 544-3131  
Fax: (599) 544-4409  
Email: sales@budmar.an

BUDGET MARINE - ANTIGUA  
Jolly Harbour Boatyard  
Bolans, Antigua, West Indies  
Ph: (268) 462-8753  
Fax: (268) 462-7727  
Email: sales@budmar.ag

BUDGET MARINE-BONAIRE  
Kaya Carlos A. Nicolaas 4  
Kralendijk, Bonaire, Netherlands Antilles  
Ph: 599-717-3710  
Ph: 599-717-3523  
Email: peter@budgetmarinebonaire.com

BUDGET MARINE-GRENADA  
L'Anse aux Epines  
Prickly Bay, St. Georges, Granada  
Ph: 473-439-1983  
Fax: 473-439-2037  
Email: budmarGD@caribsurf.com

BUDGET MARINE - ST. MARTIN  
L'île Marine  
Sandy Ground Bridge  
Rue Lady Fish  
St. Martin, FWI  
Ph: 590-290860  
Fax: 590-290896  
Email: l.ile.marine@wanadoo.fr

BUDGET MARINE - ST. THOMAS, USVI  
Vitraco Park P.O. Box 7937  
St. Thomas, USVI 00801  
Ph: 340-774-2667  
Fax: 340-774-2667  
Email: budmarsl@islands.vi

BUDGET MARINE TRINIDAD  
Western Main Road  
Chaguaramas, Trinidad, West Indies  
Ph: 868-634-2006  
Fax: 868-634-4382  
Email: sales@budmar.co.tt

## DENMARK

PABLO DIVERSIFIED  
Silkeborgvej 901  
8220 Brabrand  
Denmark  
Ph: (45) 86265655  
Fax: (45) 86265265

## ENGLAND

NAUQUIP  
11 Harvey Crescent  
Warsash, Southampton, Hants, SO3-19TA  
United Kingdom  
Ph: (44) 1489-885336  
Fax: (44) 1489-885337  
Email: David@nauquip.com

## FRANCE

SVENDSEN'S INTERNATIONAL DIST.  
c/o Jean-Michel Bernasconi  
2029 Route du bouchet  
74400 Chamonix-Mont-Blanc  
France  
Ph: (33) 0450-558041  
Fax: (33) 0450-558041  
Email: export@svendsens.com

## GERMANY

SAILTEC VERTRIEBS GmbH  
Hasselbinnen 28  
D-22869 Schenefeld Bei  
Hamburg  
Germany  
Ph: (49) 4083-04279  
Fax: (49) 4083-04279  
Email: cg@sailtec.de

## GREECE

TECREP MARINE  
A. Moutsopoulou 36  
185 36 Piraeus  
Greece  
Ph: (30) 210-4521647  
Fax: (30) 210-4184280  
Email: tcrep@ath.forthnet.gr

## HOLLAND

BELSHIP  
Krommeweterig 61A  
3543 An Utrecht  
Holland  
Ph: (31) 346-265544  
Fax: (31) 346-265475  
Email: purchase@belship.com

## ITALY

TOMASONI FITTINGS  
Via Piandilucco 11 Ir  
16155 Genova  
Italy  
Ph: (39) 010-667-1055  
Fax: (39) 010-612-9153  
Email: tomasoni@tomasoni.it

## NEW ZEALAND

KZ MARINE  
39 Vesty Dr  
Mt. Wellington, Auckland  
New Zealand  
Ph: (64) 9 573-1939  
Fax: (64) 9 573-1959  
Email: rick@kzmarine.co.nz

## SOUTH AFRICA

CENTRAL BOATING  
85 Bree Street  
Cape Town 8001  
South Africa  
Ph: (27) 021-24-8026  
Fax: (27) 021-24-2564  
Email: david@centralboating.co.za

## SPAIN

TACK-VELAS  
Pg. Joan de Borbo, 92 Local 9  
08003 Barcelona  
Spain  
Ph: (34) 93-221-8212  
Fax: (34) 93-221-8950  
Email: tackvelas@telefonica.net

## SWEDEN

BENN'S MAST & RIGGING AB  
Prastkragens Vag 20  
S-13245 Saltsjo-Boo  
Sweden  
Ph: (46) 8 556-14700  
Fax: (46) 8 448-4499  
Email: pia@benns.se

FA ROD RIGG  
Drottningholmsvagen 312  
S-161 46 Bromma  
Sweden  
Ph: (46) 8 256-025  
Fax: (46) 8 266-895  
Email: pelle-brandt@swipnet.se

## Forespar® Dealer Literature, Displays & Videos

(available to dealers at no cost)  
SEE PRICE LIST FOR ADDITIONAL LITERATURE



Forespar® 5ft x 3ft banners - great for store usage or regatta events. Available to Forespar dealers only.

- #157037 - "Forespar" banner (blue with white lettering)
- #157038 - "Forespar Sailing Gear" banner (red with white lettering)
- #157039 - "Forespar Composite" banner (black with white lettering)
- #157040 - "Forespar Leisure Furl" banner (blue with white lettering)

### Dealer Literature:

- #151102 - Lightning Master brochure
- #153309 - Nova Lift & Nova Davit brochure
- #100049 - Downwind Sailing brochure
- #102050 - Tiller Extension brochure
- #152210 - Radar Spar brochure
- #866039 - Leisure Furl quick reference guide
- #866043 - Offshore Leisure Furl brochure
- #866045 - Coastal Leisure Furl brochure
- #401041 - Pole Comparison flyer
- #401042 - Whisker Pole checklist
- #401048 - Spinnaker Pole and Whisker Pole sizing by manufacture

### Videos:

- #401045 - Using a Whisker Pole with John Kretschmer
- #401046 - Mainsail handling using Leisure Furl with John Kretschmer
- #401047 - Spinnaker Pole work with John Kretschmer



Lightning Master Brochure #151102

Nova Lift Brochure #153309

Down Wind  
Sailing Brochure #100049



# TABLE OF CONTENTS

<b>ADAPTING COLLARS, END FITTINGS (POLES)</b> . . . . .	<b>8</b>	<b>RADAR SPAR™</b> . . . . .	<b>35</b>
<b>ALUMINUM TUBING</b> . . . . .	<b>8</b>	<b>RAILFAST® HARDWARE</b> . . . . .	<b>32-33</b>
<b>AWNING POLES</b> . . . . .	<b>29</b>	<b>REACHING STRUTS</b> . . . . .	<b>15</b>
<b>BOOM VANGS</b> . . . . .	<b>17-18</b>	<b>REPLACEMENT PARTS</b> . . . . .	<b>40</b>
<b>CARGO MATE™</b> . . . . .	<b>31</b>	<b>SHACKLE GUARDS</b> . . . . .	<b>24</b>
<b>CARS, MAST</b> . . . . .	<b>9-10</b>	<b>SPINNAKER POLES &amp; EQUIPMENT</b> . . . . .	<b>5-13</b>
<b>CHOCKS, DECK MOUNTED</b> . . . . .	<b>11</b>	<b>SPINNAKER POLE ORDER FORM</b> . . . . .	<b>14</b>
<b>CHOCKS, LINE</b> . . . . .	<b>23</b>	<b>TABLE PEDESTAL SYSTEM</b> . . . . .	<b>39</b>
<b>CHOCKS, MAST MOUNTED</b> . . . . .	<b>11</b>	<b>TILLER EXTENSIONS</b> . . . . .	<b>26-28</b>
<b>CHOCKS, STANCHION MOUNTED</b> . . . . .	<b>11</b>	<b>TILLER LOCK-BOX</b> . . . . .	<b>26</b>
<b>CLEATS</b> . . . . .	<b>23</b>	<b>T-TRACK</b> . . . . .	<b>11</b>
<b>EYE-STRAP, TERMINAL</b> . . . . .	<b>29</b>	<b>TRACK STOPS</b> . . . . .	<b>11</b>
<b>HOYT JIB BOOM™ SYSTEM</b> . . . . .	<b>16</b>	<b>TUBING CLIPS</b> . . . . .	<b>26 &amp; 29</b>
<b>JIB ROLLERS</b> . . . . .	<b>24</b>	<b>WHISKER POLES</b> . . . . .	<b>2-4</b>
<b>LIGHTNING MASTER™ (STATIC DISSIPATER)</b> . . . . .	<b>15</b>	<b>WINCH, MARELON®</b> . . . . .	<b>29</b>
<b>LANOCOTE®</b> . . . . .	<b>23</b>	<b>YACHT ROD™</b> . . . . .	<b>17-18</b>
<b>LEISURE FURL™</b> . . . . .	<b>36-37</b>	<b>REPLACEMENT/REPAIR PARTS</b> . . . . .	<b>40</b>
<b>LIGHTS, MAST &amp; LIGHT GUARD</b> . . . . .	<b>19</b>		
<b>LIGHTS, PERSONAL RESCUE</b> . . . . .	<b>22</b>		
<b>LOCK REPAIR KITS</b> . . . . .	<b>4</b>		
<b>MAN-OVERBOARD POLES &amp; ACCESSORIES</b> . . . . .	<b>20-21</b>		
<b>MINI GALLEY®</b> . . . . .	<b>34</b>		
<b>MOTOR MATE™</b> . . . . .	<b>31</b>		
<b>NASH LABEL SETS</b> . . . . .	<b>25</b>		
<b>NOVA DAVIT™ &amp; NOVA LIFT™, NOVA LIFT WITH WINCH</b> . . . . .	<b>30</b>		
<b>PAD-EYES, MAST</b> . . . . .	<b>8</b>		

FOR MARELON® PLUMBING PRODUCTS SEE MARELON® CATALOG



## LIMITED WARRANTY

1. Forespar Products Corp. warrants all products manufactured by it to be free from defects in material and workmanship under normal use and with normal maintenance for a period of thirty six (36) months from the date of initial retail sale\*. The Limited Warranty is extended only to the original retail purchaser and does not run to any subsequent purchaser. Proof of purchase is required.
2. It is a condition of this Limited Warranty that the product has been given reasonable care, and that damage has not resulted from improper installation, accident, negligence, misuse including undersized for performance required or from unauthorized alterations.
3. All claims under this Limited Warranty must be made directly to Forespar Products Corp. at the address set forth within thirty (30) days after discovery of the defect. Forespar Products Corp. may require any product to be returned to its factory for examination, transportation charges prepaid.
4. The obligations of Forespar Products Corp. under this Limited Warranty are limited to repairing or replacing such products which shall be determined by Forespar Products Corp. to have been defective in materials or workmanship. Forespar Products Corp. does not under any circumstances assume responsibility for any incidental or consequential damages incurred in connection with the use of its products.

5. Forespar Products Corp. reserves the right to improve its products through changes in design and material without incurring any obligation to incorporate such changes in products already completed or in the hands of purchasers.

**6. EXCLUSION OF WARRANTIES:** This Limited Warranty is in lieu of all other express Warranties, and shall expire thirty six (36) months from the date of initial retail sale. Any implied Warranty, including the Warranty of Merchantability and fitness for a particular purpose, is limited to the duration of this Limited Warranty.

7. Some states do allow limitations on how long an implied Warranty lasts or the exclusion of incidental or consequential damages, so the above limitations or exclusion may not apply to you. This Warranty gives you specific legal rights and you may also have other rights which vary from state to state.

**8. The following items are excluded from this warranty:**  
Spar Systems and Electrical Bulbs ( mast lights & strobe lights).

\* Some products are subject to limitation of warranty duration and are so identified in the product description.

Look for this icon



# WHISKER POLES



*"I can't imagine sailing downwind without my whisker pole". I make offshore passages for a living and I count on my Forespar® whisker pole. It's an aluminum and carbon, telescoping model that gives me great flexibility when poling out my headsail. The pole is robust, well engineered and easy to set. When the wind pipes-up I'm able to keep sailing on a deep reach and if it builds more I simply furl the sail, adjust the pole length and keep blasting along. I can't imagine sailing offshore without my Forespar® whisker pole.*

*John Kretschmer  
Professional Passagemaker  
Sailing Writer*

Whisker poles are used to "wing out" the jib when sailing downwind. Sailors who have experienced downwind sailing without one can appreciate the value of being able to stabilize the jib, enabling the sail to work more efficiently.

**Forespar®** manufactures the finest and most complete line of Whisker Poles in the world. All Whisker Poles are constructed of high strength anodized aluminum tubing, and both telescoping and fixed-length models are available.

Two styles of telescoping poles are offered—the **Twist-Lock** style and the **Line-Control** style.



Where wind conditions tend to be gusty, the double latch option is recommended to avoid accidental detachment of the sheet from the pole end (**Twist-Lock** style poles).

The table below is meant to be used as a general guideline for selecting the proper whisker pole. Shown are pole recommendations relative to the following three variables: Boat Length, Sail Choice, and Wind Conditions. **Boats with relatively heavy displacements or bowsprits should use the next larger pole.**

## LEGEND

Twist-Lock Poles (ADJ/HD)  
Boats 16 - 30 Feet LOA

Line-Control Poles (LC)  
Boats 30 - 55 Feet LOA



**1**

*Un-cleat the Line.*

**2**

*Pull Line out to extend the pole.*

**3**

*Re-cleat the Line.*

## WHISKER POLE SIZE RECOMMENDATIONS

### WORKING JIB

<u>Boat Length:</u>	<u>Light to Mod. Air</u>	<u>Mod. to Heavy Air</u>
Up to 16 ft.	ADJ 4'-8'	ADJ 6'-12'
Up to 22 ft.	ADJ 6'-12'	HD 6'-12'
Up to 25 ft.	HD 6'-12'	HD 6'-12'
Up to 28 ft.	ADJ 7'-15'	ADJ 7'-15'
Up to 33 ft.	LC 10'-18'	LC 10'-18'
Up to 35 ft.	LC 12'-22'	LC 12'-22'
Up to 46 ft.	LC 13'-24'	LC 13'-24'
Up to 55 ft.	LC 15'-27'	LC 15'-27'

### GENOA

<u>Light to Mod. Air</u>	<u>Mod. to Heavy Air</u>
ADJ 6'-12'	HD 6'-12'
HD 6'-12'	LC 8'-14'
ADJ 7'-15'	ADJ 7'-15'
ADJ 7'-15'	LC 10'-18'
LC 10'-18'	LC 12'-22'
LC 12'-22'	LC 13'-24'
LC 13'-24'	LC 15'-27'
LC 15'-27'	Carbon Fiber Custom Poles

## LINE CONTROL™

### 50/50 CARBON/ALUMINUM "COMBO" WHISKER POLES

These Line Control™ Whisker poles offer just the right blend of aluminum and carbon structures to provide the racing or cruising sailor weight and cost savings. They have the strength and weight savings of carbon on the inner tube and the abrasion resistance, durability and cost savings of aluminum on the outer tube. They also feature Forespar's exclusive "Ultra" end fittings (UTS socket inboard and UTR trigger outboard) for further weight reduction and ease of maintenance.

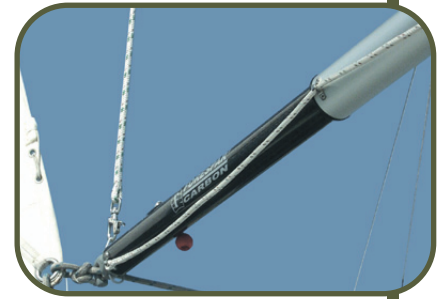

### "PATENTED" LINE CONTROL™ WHISKER POLES

Line Control™ is a proven concept in telescoping whisker pole design. So unique, that full patent protection has been secured. Line Control™ is only available on Forespar® whisker poles. See the chart below for pole lengths and tube sizes. The system is simple, and makes the extension and retraction of poles quick and easy. And most amazing of all . . . the entire operation can be executed while being positioned at the mast. It is no longer necessary to go forward to adjust buttons of any kind — simply uncleat the line and extend or retract (never attempt to adjust while under load). It's quick and easy even with the largest poles. Topping lift attachment points are on all poles. Attachment to outer end is with end fittings jaw facing down.



Part No.	Model No.	End fittings		Recommended Mast Fittings	Collapsed Length / Weight	Max. Working Length	Tubing Diameters
		Inboard	Outboard				
401106	LC 10-18 EL-UXP	EL	UXP	PE-3SC, RC-125, FC-125	121.75"/17 lbs.	218.13"	2" & 2-1/2"
401107	LC 10-18 EL-UTR	EL	UTR	PE-3SC, RC-125, FC-125	121.75"/17 lbs.	218.13"	2" & 2-1/2"
402200	LC 12-22 UXP-UTR	UXP	UTR	RC-125, FC-125	148.50"/27 lbs.	265.25"	2-1/2" & 3"
402201	LC 12-22 UTS-UTR	UTS	UTR	T-125, AT-125	148.50"/28 lbs.	265.25"	2-1/2" & 3"
800802	LC 12-22 UTS-UTR-CF	UTS	UTR	T-125, AT-125	148.50"/19 lbs.	265.25"	2-1/2" & 3"
402203	LC 12-22 COMBO	UTS	UTR	T-125, AT-125	148.50"/24 lbs.	265.25"	2-1/2" & 3"
403200	LC 13-24 UXP-UXP	UXP	UXP	RC-125, FC-125	162.00"/38 lbs.	272.00"	3" & 3-1/2"
403202	LC 13-24 UTS-UTR	UTS	UTR	T-125-S	162.00"/39 lbs.	272.00"	3" & 3-1/2"
800800	LC 13-24 UTS-UTR-CF	UTS	UTR	T-125, AT-125	162.00"/24 lbs.	272.00"	3" & 3-1/2"
403203	LC 13-24 COMBO	UTS	UTR	T-125, AT-125	162.00"/34 lbs.	272.00"	3" & 3-1/2"
405200	LC 15-27 UTS-UXP	UTS	UXP	T-125-S	182.00"/58 lbs.	324.00"	3-1/2" & 4"
405201	LC 15-27 UTS-UTR	UTS	UTR	T-125-S	182.00"/58 lbs.	324.00"	3-1/2" & 4"
800801	LC 15-27 UTS-UTR-CF	UTS	UTR	T-125, AT-125	182.00"/32 lbs.	324.00"	3-1/2" & 4"
405203	LC 15-27 COMBO	UTS	UTR	T-125, AT-125	182.00"/42 lbs.	324.00"	3-1/2" & 4"

SEE REPLACEMENT PARTS PAGE

(CF Indicates Carbon Fiber poles)

# WHISKER POLES

## SMALL TELESCOPING POLES (TWIST LOCK)

Telescoping models can be adjusted to any desired length and securely locked in position with an effortless twist of the inner tube. All small poles include strong corrosion-free Lexan end fittings and a Mast Pad Eye with stainless steel screws.



Part No.	Model No.	Size/Weight
404000	ADJ 4-8	Telescopes from 53" to 93"/3 lbs. 1" outer diameter
404100	ADJ 4-8 DL	With latch fittings on both ends
406000	ADJ 6-12	Telescopes from 72" to 134"/3 lbs. 1- 1/4" outer diameter
406100	ADJ 6-12 DL	With latch fittings on both ends
404011	PE-1	Pad Eye Only
300026	ADJ 4-8	End kit
300027	ADJ 6-12	End kit

## HEAVY DUTY TELESCOPING POLES (TWIST LOCK)

These telescoping whisker poles are heavy duty two section and three section aluminum spars which can be extended to lengths up to 17' and securely locked in position by an internal twist lock device. Poles feature self-latching **Ultra Series™** fittings on the inboard and outboard ends (**PE-3SF or PE-3SC Mast Pad Eyes recommended**). **SEE PAGE 8**



Part No.	Model No.	Size/Weight
406300	HD 6-12-DL	Two sections extending from 79" to 138", 1-7/8" outer tube diameter. With self-latching fittings on both ends/8 lbs.
407101	ADJ 7-15-DL	Three sections extending from 83" to 169", 2 in. outer tube diameter. With self-latching fittings on both ends/8 lbs.
304015 UEF-3	HD 6-12 DL	Special – inboard (big) end only
304018 UEF-5	HD 6-12 DL	Outboard end only (small)
304057 UEF-3	ADJ 7-15 DL	Inboard (big) end only
304018 UEF-5	ADJ 7-15-DL	Outboard end only (small).

## LOCK REPAIR KITS\*

To recondition any of our twist-lock telescoping poles, we offer lock repair kits. Complete instructions and all necessary parts are provided.



Part No.	Lock for:
400006	TAP's & ADJ 4-8's
400007	BHT's & TAP HD's
400008	ADJ 6-12
400009	HD 6-12
400010	ADJ 7-15 (Two-lock set)



Courtesy of Flying Scot, Inc.

**\*Individual sections and additional parts are available for repairing whisker poles.**

**SEE REPLACEMENT PARTS PAGE**

**Forespar®** offers a complete and diversified line of spinnaker poles. We manufacture eight complete end styles from which we create a multitude of combinations to fit the needs of all sailors - racers or cruisers.

## CUSTOM POLES & KITS

**Forespar®** offers "customized" poles built to specific dimensions, and also "kit" poles in which both ends are left loose to allow the marine dealer or yachtsman to finish the pole himself. End fittings and tubing are available separately for those who wish to assemble poles to their own specifications.

## DETERMINING POLE LENGTH

The length of your spinnaker pole is determined by the yacht's "J" measurement. This is roughly the straight line distance from the front of the mast at deck level to the headstay. The "J" measurement is available from your sailplan, or contact **Forespar®** and we will be able to assist you in determining the proper length.

The "kit" lengths that are shown on the following pages are the maximum we recommend for each tubing diameter. However, oversized poles are available.

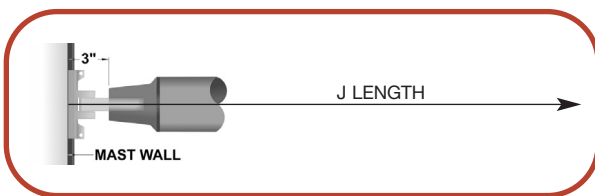

FOR POLES WITH OUR TS & UTS END FITTING, AND USING A **FORESPAR®** T-125-S CAR, 3" IS SUBTRACTED WHEN GIVEN A 'J' DIMENSION TO ESTABLISH POLE LENGTH.

## RETRACTABLE BRIDLE OPTION

For custom spinnaker poles 3" in diameter or larger only. Featuring internal outboard-end trip lines, and a retractable topping lift, this rigging allows the sailor to smoothly complete a spinnaker jibe without detaching the pole from the mast.

Part No.	Description
300032	Retractable Bridle Option

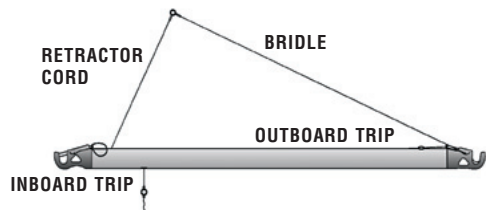
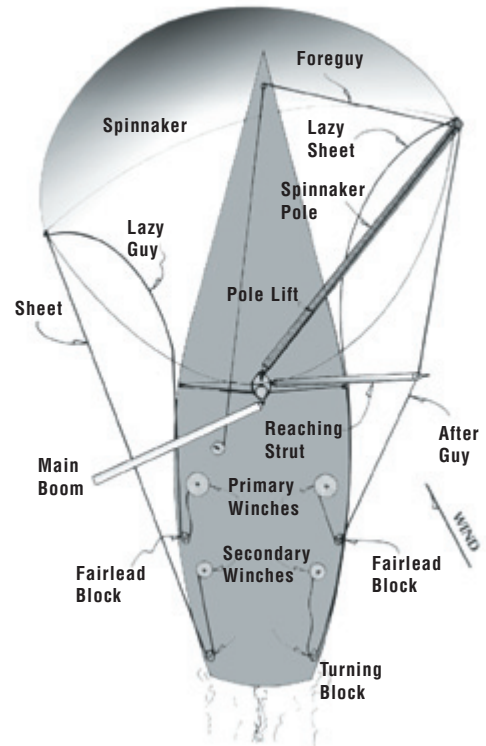

## TECH. TIPS - ABOUT THE CARE OF FITTINGS

Yachtsmen take particular care when painting or varnishing their hulls, looking after sails, spars and rigging, and then, for the most part, forget to maintain their poles, valves, and deck fittings. The most effective method of keeping deck hardware (e.g. pole ends, cams etc.) working freely is to wash them thoroughly with fresh water after every race or cruise. This is especially important when using spinnaker/whisker poles, tiller extensions or other telescoping equipment. Salt and sand that is not cleaned out can destroy the locks, cams, springs or rollers in a matter of months. **Forespar® strongly advises against the use of lubricants on pole ends and telescoping poles.** This can clog spring housings and ball bearings and can destroy twist-lock components. As a general rule, all fittings on deck, whether a dinghy or an ocean racer, should be maintained regularly. As previously mentioned, the best treatment is fresh water washing/flushing. This attention to maintenance will ensure that every fitting on your yacht will function at its best and attain a maximum performance life.

# SPINNAKER POLE END FITTINGS

## FORESPAR'S ULTRA SERIES™

Represents the cutting edge in spinnaker pole end fitting technology. Designed for high strength, very low weight and resistance to wear and corrosion the **Ultra Series™** composite end fitting is perfect for aluminum or carbon fiber spinnaker poles and whisker poles. The **Ultra Series™** is the sailor's choice for inshore and offshore racing and cruising. Available with or without triggers. Maximum LOA Boat Outboard End - 43'. Maximum LOA Boat Inboard End - 36'. All larger boats use GP Series.

Part No. w/ trip*	For Pole Model No.	Fits Diameter	Tube I.D.	End Fitting Length	End Fitting Weight
304054	UXP-150-EF	1.5"	1.370"	2.750"	6.97 oz.
304050	UXP-200-EF	2.0"	1.870"	2.750"	6.97 oz.
304051	UXP-250-EF	2.5"	2.334"	3.125"	9.25 oz.
304052	UXP-300-EF	3.0"	2.835"	3.000"	11.92 oz.
304053	UXP-350-EF	3.5"	3.260"	3.625"	15.72 oz.

"UXP" External Trip



"UTR" Internal Trip

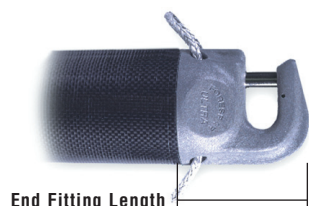

\*Trip line is Spectra™ with terminal eyestay included. Length is sufficient for standard pole lengths based on diameter.

Part No. w/ trip*	For Pole Model No.	Fits Diameter	Tube I.D.	End Fitting Length	End Fitting Weight
304060	UTR-200-EF	2.0"	1.870"	2.750"	6.97 oz.
304061	UTR-250-EF	2.5"	2.334"	3.125"	9.25 oz.
304062	UTR-300-EF	3.0"	2.835"	3.000"	11.92 oz.
304063	UTR-350-EF	3.5"	3.260"	3.625"	15.72 oz.

\*All ultra ends require minimum 1.5 inch i.d. rings to function properly. Undersized rings will damage ends and void warranty.

## AUTOMATIC SOCKET END - TS & UTS

This unique "socket" type fitting automatically locks onto the mast toggle pin with a quick and easy push. The release is just as quick with a press of the lever (fits Forespar® mast toggle pins only).

"TS" Style

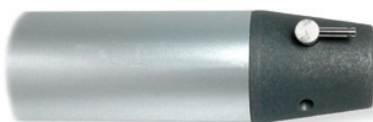

For Pole Part No.	Fits Model No.	Weight Diameter	Tube I.D.	w/o trip
309028	TS-300-EF (Aluminum)	3.0"	2.835"	1 lb 10 oz
304080	UTS-300-ULTRA	3.0"	2.835"	1 lb 4 oz
309031	TS-350-EF (Aluminum)	3.5"	3.260"	1 lb 13 oz
304081	UTS-350-ULTRA	3.5"	3.260"	1 lb 7 oz
405006	TS-400-EF (Aluminum)	4.0"	3.750"	2 lb 2 oz
309036	TS-450-EF (Aluminum)	4.5"	4.260"	2 lb 13 oz
304082	UTS-400-ULTRA	4.0"	3.750"	1 lb 7 oz
304083	UTS-450-ULTRA	4.5"	4.260"	1 lb 7 oz

## OFFSHORE SERIES GRAND PRIX END GP & ULTRA SERIES™-GPS

The **UGPS** end fitting comes with a stainless steel lined throat. As always, this deluxe ocean racing end fitting features a wide flared throat. Both the GP and **UGPS** ends also feature our proven spring loaded piston system with roller for positive lock and release. **All UGPS and GP ends for outboard pole end use only. Will not work with mast cars. All outboard ends are internal trip only.**

"UGPS" Style **MAXIMUM BOAT LENGTH 60'**

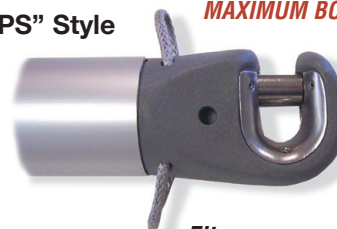

Part No.	For Pole Model No.	Fits Tube Dia.	Tube I.D.	Weight w/o trip	End Fitting Length
304021	UGPS-300-EF-ULTRA	3.0"	2.835"	2 lb 6 oz	5.00"
304022	UGPS-350-EF-ULTRA	3.5"	3.260"	2 lb 9 oz	7.00"
304023	UGPS-400-EF-ULTRA	4.0"	3.750"	2 lb 3 oz	7.25"
304024	UGPS-450-EF-ULTRA	4.5"	4.260"	3 lb 3 oz	8.50"

"GP" Style **MAXIMUM BOAT LENGTH 75'**



Part No.	For Pole Model No.	Fits Tube Dia.	Tube I.D.	Weight w/o trip	End Fitting Length
309030	GP-300-EF (Aluminum)	3.0"	2.835"	2 lb 12 oz	5.00"
309033	GP-350-EF (Aluminum)	3.5"	3.260"	3 lb 6 oz	7.00"
309035	GP-400-EF (Aluminum)	4.0"	3.750"	3 lb 14 oz	7.25"
309038	GP-450-EF (Aluminum)	4.5"	4.260"	4 lb 13 oz	8.50"

## ULTRA SERIES™ GRAND PRIX OUTBOARD POLE END

Forespar's **ULTRA SERIES™** composite pole end fittings have been a proven, overwhelming success. Their light weight and resistance to corrosion answer racing and cruising sailor's needs for strength and reliability. The Grand Prix **ULTRA SERIES** include sizes suitable for yachts sixty feet LOA. The **ULTRA Grand Prix, UGPS**, model with a stainless steel throat liner insert weighs only 38 ounces.



## STANDARD SPINNAKER POLES

Our Standard Spinnaker Poles have a double bridle topping lift/foreguy system. Unless otherwise specified, all standard poles are supplied with the throat (jaw) facing upward. See price page for information regarding charges for special tubing.

### STANDARD SPINNAKER POLES - KIT OR CUSTOM LENGTHS

(Requires a Forespar® Ring Style, Flange Style or Toggle Car See Pages 11 & 12)

Part No. Kit	Part No. Complete	Model Number	Shipping Weight	Kit Length (w/ends)	Description
304000	304100	UXP-150-UXP	6 lbs.	7'-8" Approx.	<b>ULTRA</b> Piston fitting both ends.
304001	304101	UXP-200-UXP	10 lbs.	9'-6" Approx.	<b>ULTRA</b> Piston fitting both ends.
304002	304102	UXP-200-UTR	11 lbs.		<b>ULTRA</b> Trigger one end/ <b>ULTRA</b> Piston other.
304003	304103	UTR-200-UTR	11 lbs.	2" Dia.	<b>ULTRA</b> Trigger fitting both ends.
304004	304104	UXP-250-UXP	14 lbs.	11'-6" Approx.	<b>ULTRA</b> Piston fitting both ends.
304005	304105	UTR-250-UXP	15 lbs.		<b>ULTRA</b> Trigger one end/ <b>ULTRA</b> Piston other.
304006	304106	UTR-250-UTR	15 lbs.	2 1/2" Dia.	<b>ULTRA</b> Trigger fitting both ends.
304007	304107	UXP-300-UXP	18 lbs.	13'-6" Approx.	<b>ULTRA</b> Piston fitting both ends.
304008	304108	UTR-300-UXP	19 lbs.		<b>ULTRA</b> Trigger one end/ <b>ULTRA</b> Piston other.
304009	304109	UTR-300-UTR	19 lbs.	3" Dia.	<b>ULTRA</b> Trigger fitting both ends.
304010	304110	UXP-350-UXP	33 lbs.	15'-5" Approx.	<b>ULTRA</b> Piston fitting both ends.
304011	304111	UTR-350-UXP	33 lbs.		<b>ULTRA</b> Trigger one end/ <b>ULTRA</b> Piston other.
304012	304112	UTR-350-UTR	34 lbs.	3 1/2" Dia.	<b>ULTRA</b> Trigger fitting both ends.

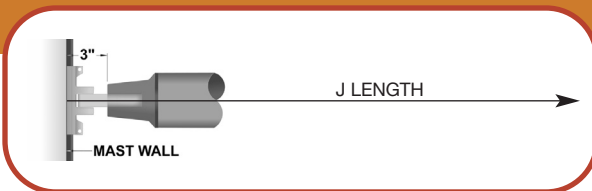

FOR POLES WITH OUR TS & UTS END FITTING, AND USING A FORESPAR® T-125-S CAR, 3" IS SUBTRACTED WHEN GIVEN A 'J' DIMENSION TO ESTABLISH POLE LENGTH.

## CUSTOM OFFSHORE SPINNAKER POLES

The Forespar® Offshore Series spinnaker poles provide the serious racer with rugged, reliable and efficient equipment. These poles are designed to withstand the rigors of extended offshore racing.

Note: Due to the variety of personal preferences concerning bridle and topping lift rigging on offshore end type poles, no "standard" rigging is included on the poles below. If so specified, an end-to-end or a single topping lift can be supplied.

**OFFSHORE POLES (Requires a Forespar® AT, T-125-S or AT-150-S Toggle Car See Page 11)**

Part No. Custom	Model Number	Shipping Weight	Kit Length (w/ends)	Description
302028	TS-300-GP	22 lbs.	14'	Socket Inboard/GP Outboard.
304115	UTS-300-UTR	18 lbs.	13.5'	<b>ULTRA</b> Socket Inboard/ <b>ULTRA</b> Trigger Outboard.
304116	UTS-300-UGPS	19 lbs.	13.5'	<b>ULTRA</b> Socket inboard/ <b>ULTRA</b> GPS Outboard.
302032	TS-350-GP	35 lbs.	15.5'	Socket Inboard/GP Outboard.
304117	UTS-350-UTR	33 lbs.	15'	<b>ULTRA</b> Socket Inboard/ <b>ULTRA</b> Trigger Outboard.
304118	UTS-350-UGPS	34 lbs.	15'	<b>ULTRA</b> Socket inboard/ <b>ULTRA</b> GPS Outboard.
302036	TS-400-GP	47 lbs.	19'	Socket Inboard/GP Outboard.
304119	UTS-400-UGPS	44 lbs.	18.5'	<b>ULTRA</b> Socket Inboard/ <b>ULTRA</b> GPS Outboard.
302040	TS-450-GP	52 lbs.	21'	Socket Inboard/GP Outboard.
304120	UTS-450-UGPS	49 lbs.	20.5'	<b>ULTRA</b> Socket Inboard/ <b>ULTRA</b> GPS Outboard.

## UTR 3 & 3.5 TRIGGER STYLE ENDS

All UTR 3 & 3.5 trigger style ends have adjustable screw for adjusting spring tension.



Anti-rotational pin allows activation at trigger end.

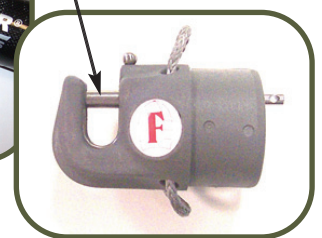

**NEW**

# ALUMINUM TUBING & SPINNAKER POLE KITS

## ADAPTING COLLARS

For sleeving **Forespar**® spinnaker pole end-fittings for use on larger diameter tubing, and other applications.



Part No.	Model No.	Adapts:
304049	AC-2 <b>"ULTRA"</b>	2.00" to 2.50"
304048	AC-3 <b>"ULTRA"</b>	3.00" to 3.50"
309020	AC-4 (Aluminum)	4.00" to 4.50"
309082	AC-5 (Aluminum)	5.00" to 3.00"
309083	AC-6 (Aluminum)	6.00" to 3.00"
304085	<b>"ULTRA"</b>	3.00" to 4.00"
304086	<b>"ULTRA"</b>	3.00" to 4.50"

## ALUMINUM TUBING

Clear anodized to military specification (triple commercial). Prime marine alloy 6063-T6. All tubing sold in stock lengths.

Part No.	O.D.	Stock Lengths	Wall	I.D.	Wt./ Ft.
500015	1-1/4"	20'	.050"	1.150"	.22 lbs
500018	1-1/2"	22'6"	.065"	1.370"	.35 lbs
408002	1-1/2"	7'2"	.065"	1.370"	.35 lbs
301005	1-1/2"	7'6"	.065"	1.370"	.35 lbs
500020	2"	21'6"	.065"	1.870"	.47 lbs
408003	2"	7'2"	.065"	1.870"	.47 lbs
401004	2"	9'1"	.065"	1.870"	.47 lbs
301006	2"	9'4"	.065"	1.870"	.47 lbs
301058	2-1/2"	20'2"	.083"	2.334"	.74 lbs
301056	2-1/2"	9'	.083"	2.334"	.74 lbs
301057	2-1/2"	11'2"	.083"	2.334"	.74 lbs
301065	3"	11'2"	.083"	2.835"	1.00 lb
301072	3"	12'2"	.083"	2.835"	1.00 lb
301019	3"	13'	.083"	2.835"	1.00 lb
301063	3"	16'	.083"	2.835"	1.00 lb
301030	3"	23'4"	.083"	2.835"	1.28 lb
301061	3-1/2"	24'4"	.120"	3.260"	1.50 lb
403004	3-1/2"	12'2"	.120"	3.260"	1.50 lb
301059	3-1/2"	14'	.120"	3.260"	1.50 lb
301024	3-1/2"	15'	.120"	3.260"	1.50 lb
301003	4"	20'	.120"	3.750"	1.72 lb
301069	4-1/2"	20'	.120"	4.260"	1.94 lb

\* CUSTOM TUBING IS ALSO AVAILABLE BY THE FOOT, CALL FOR PRICING



## TECH. TIPS - ABOUT ULTRA STYLE END FITTINGS

### Proper attachment of Ultra style end fittings to carbon & aluminum tubes

**Forespar**® Ultra Series composite ends requires careful attention to fasteners style and placement. The Ultra material is extremely strong and durable at half the weight of their aluminum counterparts but require the use of pan head machine screws-not rivets or glue-for proper attachment to carbon or aluminum tubing. Drill and tap the holes.

Placement of the fasteners is also critical to the strength of the attachment to the pole, especially when an adapting collar (i.e. 2" ends on 2-1/2" tube) is used.

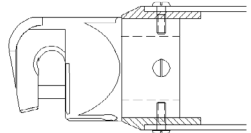

The S/S PHMS (pan-head machine screws) must be placed so they engage the adapting collar and the core of the end fitting to the tube. The fasteners for aluminum tubes should be placed 1/2" back from the end of the tube onto the (flange) collar on 2-1/2" and 3-1/2" sizes and the basic ends without collars on 2" & 3" sizes. Use a minimum of 4) 10-24 PHMS on ends 2", 2-1/2" and 3" and 5) on 3-1/2" to 4", 6) or more 1/4-20 PHMS may be needed on larger diameter tubes. On carbon tubes, place the fasteners 3/4" back from the end of the tube.

Be careful not to drill into the spring/piston housing on either style end (UTR & UXP) and not to hit the "set screws" on the sides (left and right side on the core) of the UTR style ends. Be sure to offset your hole pattern to clear these components and double check before you drill and tap! On carbon tubes, be sure not to over tighten and stress or crack the fiber laminate. If the carbon tube does not fit to the end fittings tight, wrap 2" masking tape around the core (bury of the end) until you achieve a snug fit.

## PE-3SF & PE-3SC PAD-EYES

To compliment our medium size Whisker Poles (LC 10-18); **Forespar**® designed the stainless steel **PE-3SF & PE-3SC Mast Pad Eyes**. Measuring 2-3/4" x 2", both pad-eyes have inside ring diameters of 1-5/8". **PE-3SF** is for flat mast surfaces. **PE-3SC** is slightly bent to better accommodate a curved mast.

#400001



#400002



#400012



Part No.	Model No.
400001	PE-3SF (Flat Base)
400002	PE-3SC (Curved Base)
400012	PE-3-SSF w/ struts (Flat Base)

**SEE REPLACEMENT PARTS PAGE**

## SMALL BOAT SPINNAKER POLE KITS

Each kit includes anodized aluminum tubing, Nylon latching end fittings, nylon lanyard, pad-eye and epoxy kit. One end is loose so you can cut tubing to desired over-all length and then fasten end fitting with epoxy supplied. Less than 10 minutes to complete.



Part No.	Model No.	Size/Weight
303600	Mini-6	1" dia.-6' Kit/4 lbs.
303700	Mini-7	1-1/4" dia.-7' Kit/4.5 lbs.

## TOGGLE CARS 1-1/4" & 1-1/2" (For Offshore Poles)

This car slide is offered both in stainless steel and hard coat anodized extruded aluminum. The toggle-pin is stainless steel in each case. Toggle assemblies available separately see replacement parts page. Our strong 1-1/2" toggle spinnaker car is for boats approx. 50' to 70' LOA. Fits the standard Schaefer 41-12 1-1/2" track. Low friction movement due to UHMW inserts.

To allow vertical storage on the mast of larger poles up to 6" diameter, specify our long toggle option. Our standard toggle works with poles to 4-1/2" diameter.

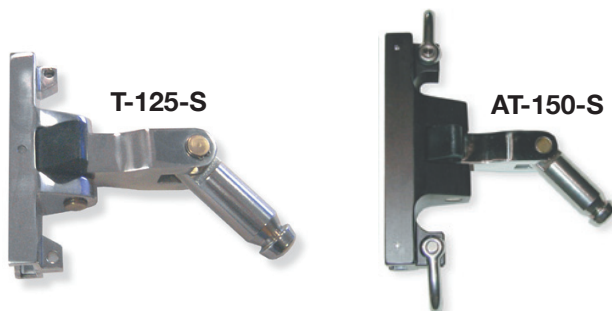

Part No.	Model No.	Track Size
333004	T-125-S (S/S Body)	1-1/4"
333020	Long Toggle Option	
333010	Toggle & Knuckle Assembly	
334100	AT-150-S (Alum. Body)	1-1/2"
331013	Replacement Runners	

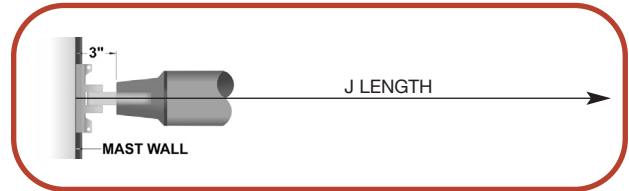

FOR POLES WITH OUR TS & UTS END FITTING, AND USING A **FORESPAR® T-125-S CAR**, 3" IS SUBTRACTED WHEN GIVEN A 'J' DIMENSION TO ESTABLISH POLE LENGTH.



### TECH. TIPS - MAST CAR & PAD EYE RING DIA.

Many masts on boats built through the 70's and early 80's came with mast pad eyes or ring cars for attachment of the spinnaker pole. These were fixed eyes or sliding cars with relatively small ring diameters. Some were as small as 1" I.D.

**Forespar®** "Ultra" series end fittings (both the UXP and UTR style) require a minimum of 1-1/2" I.D. rings for proper function. If the ends are used on rings less than 1-1/2" I.D. the jaws ("beak") can bind-up in the rings and with the leverage of an 8' pole, (or longer!) the ends will fail.

This is not the fault of the end fittings. A proper sized ring will avoid this and allow the ends to freely move under spinnaker pole compression loads as needed.

**Forespar®** offers S/S mast pad eyes (PE-3-SF & PE-3-SC) and sliding ring cars (RC-125) with 1-5/8" I.D. rings for use with our end fittings. Lesser diameter rings should be changed-out to avoid potential failure to ends due to insufficient clearance.

**Forespar®** will not warrant ends that fail due to improperly sized rings on the mast.



MINIMUM RING INNER DIAMETER MUST BE 1-1/2" OR MORE (UP TO 2" MAXIMUM) FOR PROPER FUNCTION OF FORESPAR END FITTINGS

## RING STYLE MAST CAR - RC 125

The ring and body of this unusually strong car is investment cast of 17-4 heat treated stainless steel to provide a superior product. Compatible with our "UXP" and "UTR" pole end fittings. Ring I.D. is 1-5/8".

The **RC-125** is for 1-1/4" T-track and has a screw lock-pin, our special UHMW polyethylene slides and provisions for up and downhaul shackles.

**RC-125 car is NOT recommended for use with poles that are to be stored vertically up the mast. Use FC-125, #332002**



Part No.	Model No.
331000	RC-125

**SEE REPLACEMENT PARTS PAGE**



Courtesy of Geri Conser

## HEAVY DUTY CAR — FC-125

These spinnaker cars are designed for the yachtsman who wants a safe, effective means of pole attachment for less than the price of the pin type car. The heavy duty FC-125 spinnaker car allows both vertical and horizontal movement while eliminating undesirable twisting motion of the spinnaker pole. The car slide is high strength, hard anodized aluminum alloy. The pole acceptance jaw is stainless steel.

Fits all standard 1-1/4" X 3/16" flat stainless or aluminum T-track. Recommended for "UTR" and "UXP" type spinnaker pole ends.



FC-125

Part No.	Model No.
332002	FC-125



## TECH. TIPS - ABOUT VERTICAL POLE STORAGE

Storing poles (whisker or spinnaker) vertically up the forward face of the mast has become very popular. It clears the decks and keeps the cruising sailor from having to lift the entire weight of the pole from the deck to the mast car. It can, however, cause a few problems or failures if not used with the correct components.

Selection of the proper mast car and inboard end fitting combination is critical. Ring style cars (ours or anyone else's) will not allow a pole to hang vertically without binding and eventually breaking the end fitting. Bear in mind that you have a significant "lever arm" effect on the end. A 10-foot pole can create enough leverage to fracture or bend ends and rings if they bind up without you ever feeling it from the opposite end of the pole. Therefore, **Forespar®** does not recommend ANY ring style mast cars if the pole is to be stored up the mast.

If using latch style ends ("UXP" & "UTR" Ultra ends or older "XP", "TR" & "EL" aluminum ends) the FC-125 (#332002) flange style car (this page) is designed to allow up to a 4-1/2" diameter pole to hang vertically without binding up. The Toggle style cars (preceding page) will also allow mast storage with the "offshore" style "TS" & "UTS" style ends.

To aid in vertical pole storage, **Forespar®** has designed the "VPC" (this page) vertical pole storage cars in 2-1/2" to 4" sizes. These cars are designed to attach to the FC-125 or toggle style cars with a short "tail" (line or wire) and run in tandem up and down the track. When the pole is in use, they hang below the mast car and out of the way. Most importantly, when the pole is raised to the vertical storage position, the VPC car is raised up the track and engages the pole near the top. This not only keeps the pole on the centerline (important with toggle cars) but also dampens the poles movement when at anchor. When used with the appropriate deck chock, (also on the mast) the pole can safely be stored up the mast and sheets will not foul on the outboard pole end that is captured by the deck chock on the mast. It is important that all components are on the mast so that the stored pole comes as close to parallel to the mast as possible.

If storage of the pole up the mast is your choice, we also strongly recommend securely mounted deck chocks be available for severe weather. It is advisable to remove poles from the mast and store them on deck in storm conditions. This removes the weight and windage aloft and keeps the poles available for an emergency should your rig be carried away.

If vertical pole storage is not desirable, **Forespar®** offers stanchion chocks (page 11) and standard deck chocks for pole storage as well.



## VERTICAL POLE STORAGE CAR

Available in four sizes; this mast fitting can be rigged with our FC-125 and T-125 mast cars.

This mast fitting is a simple solution to vertical pole storage problems. The VPC-125 retains the upper end of the stowed pole on the mast centerline. The chock slides on the track and eliminates rattle, vibration and binding of the pole end. All four cars fit 1-1/4" T-Track.



Part No.	Model No.
335100	VPC-125-250
335101	VPC-125-300
335102	VPC-125-350
335103	VPC-125-400

# POLE CHOCKS & SPINNAKER TRACK

## DECK CHOCKS

**Forespar**® deck chocks are used to stow our spinnaker poles or whisker poles on the deck. We strongly recommend poles be stored on deck for heavy weather. The "Ultra" deck chocks will accept all **Forespar**® pole fittings. These chocks have been designed and made from Marelon for rugged use while incorporating a "snag-proof" low profile.

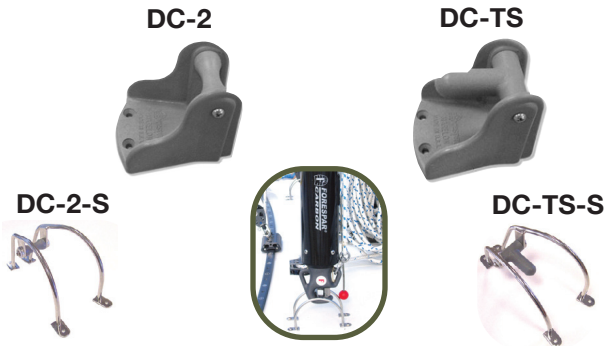

Part No.	Model No.	Description
300002	DC-2 "ULTRA"	(For UXP, UTR, GP & UGPS end fittings)
300013	DC-TS "ULTRA"	(For TS & UTS end fittings)
300028	DC-TS-S	(Stainless steel, for UTS & TS ends)
300029	DC-2-S	(S. steel, for UXP, UTR, UGPS & GP ends)

## STANCHION MOUNTED POLE CHOCKS

Clear the decks! Now you can stop stumbling over deck mounted poles. These chocks are molded from durable, weather-resistant urethane and mount easily onto 1" stanchions — no drilling necessary. For poles 2" to 3-1/2" in diameter. (Chocks are sold individually — two chocks are needed for each pole.) For spinnaker or whisker poles. Ideal for reaching struts!



Part No.	Model No.	For Pole Diameter
300050	SC 200	2"
300042	SC 250	2-1/2"
300043	SC 300	3"
300044	SC 350	3-1/2"

## MAST MOUNTED CHOCKS

**(For Vertical Pole Mounting on the Mast)**

Molded from durable high tech urethane, these chocks allow for stowing the pole vertically against the face of the mast. Off the deck and out of the way! Two MPC chocks mounted 2-3 feet apart will help stop the pole from rattling.

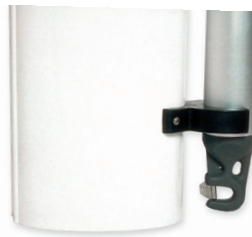

Part No.	Model No.	Description
300070	MPC 200	2" Mast Pole Chock
300071	MPC 250	2-1/2" Mast Pole Chock
300072	MPC 300	3" Mast Pole Chock
300073	MPC 350	3-1/2" Mast Pole Chock
300074	MPC 400	4" Mast Pole Chock

## T-TRACK 1-1/4"

**Forespar**® offers clear anodized aluminum T-track in one standard size. Track comes pre-drilled with alternating pin-stop and mounting holes. The base of the track is gently curved to better accommodate mast surfaces. Available lengths — 4', 6', 8', 10' and 20'. The recommended fasteners are 5/16" x 3/4" Flat-head machine screws.

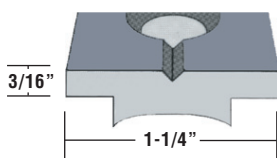

Part No.	Model No.
339003	T-Track (per ft.)

## ALUMINUM TRACK STOP — AS-125

Anodized aluminum construction prevents the cracking and shattering common with plastic stops. Sold individually.



Part No.	Model No.
339002	AS-125

## T-TRACK INSERT

These four foot sections of polypropylene inserts are for use on Z-Spar (Z Diffusion) masts found on many boats sold in the U.S. They will fill the slot found in the front center of the forward face of spars designed for cars not suitable for use with **Forespar**® end fittings. They provide a base for the mounting of standard 1-1/4" "T" track to allow the use of our various 1-1/4" mast cars. They are easily drilled and will not promote corrosion under the track.

Part No.	Model No.
339006	T-Track Insert (4 ft.)

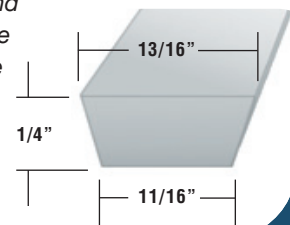

# CARBON SPINNAKER & WHISKER POLES

## FORESPAR® SETS THE STANDARD IN DOWNWIND SAILING EQUIPMENT!

Forespar® has perfected the art of manufacturing carbon fiber equipment not only for the blue water yachts and racers but now for the recreational sailor as well. We have manufactured standard composite poles for over 10 years. We made our first carbon fiber mast in 1979, ten years before anyone else in the U.S.

Forespar® is the world leader in standard composite whisker poles, spinnaker poles and reaching struts. Standard sizing is 2" – 6". Spinnaker poles are offered in double tapered as well as parallel configurations. In addition, we custom design and make poles or bow sprits specifically sized for the head sail of your choice; code zeros, asymmetrical chutes, spinnakers or roller furling genoas.

Typically a composite spinnaker pole will be 40% lighter than a similar aluminum pole yet almost 50% stiffer! Fixed length whisker poles and bow sprits are 50% lighter.

All Forespar® poles are manufactured in the U.S.A. and assembled in our California plant by professional riggers. HIGH MODULUS ENGINEERING, the premier composite design firm for the 2003 America's Cup racing, is our partner in design and brings to the Forespar® design efforts the wealth of composite engineering learned during this year's cup races.



### CARBON FIBER FIXED LENGTH WHISKER POLES

Forespar® carbon fiber poles available in deep epoxy clear coat or any Awlgrip color.

### CUSTOM POLES

California "carbonwood" poles are faux spruce painted poles which give poles the rich wood grain look.



### CARBON FIBER LINE CONTROL WHISKER POLES

Line Control pole inner tube is epoxy clear coat carbon fiber and the outer tube is Awlgrip white coated carbon fiber.

### CENTER POINT POLES

Smaller diameter poles can be made with "center point" pick up "D" ring attachments



### CARBON FIBER SPINNAKER POLES

Shown with optional Kevlar™ chafe protection.



## CLASS LEGAL CARBON POLES

Part No.	Model No.
800124	J24
800104	Tartan 10, UXP-250-UXP CF
800204	Beneteau 36.7, UTR-300-UTR CF
800306	Mumm 30
800405	Beneteau 40.7

# CARBON FIBER SPINNAKER POLES & WHISKER POLES

## CARBON FIBER SPINNAKER POLES & WHISKER POLES

Forespar's Composites Division has years of experience in the production of high performance poles for racing and cruising boats. Weight reductions over similar aluminum poles are typically 50% or better. Poles from 2.5" to 4.5" diameters are straight tubes unless custom 4.5" to 3.5" taper is requested. All 5" diameter and larger tubes have double tapered ends. Forespar® poles are produced from pressure cured intermediate modulus carbon fiber, and high performance epoxy resin systems.

Part No.	O.D.	Approx. Total Weight	End Fittings	Bridles	Maximum Length	Standard Finish
<b>Straight Non-Tapered Tubes</b>						
800901	2.0"	4 lbs.	UXP-UXP	Double	10.0'	EZ Grip
800101	2.5"	4.5 lbs.	UXP-UXP	Double	12.0'	EZ Grip
800102	2.5"	4.5 lbs.	UTR-UTR	Double	12.0'	EZ Grip
800201	3.0"	8 lbs.	UXP-UXP	Double	14.0'	EZ Grip
800202	3.0"	8 lbs.	UTR-UTR	Double	14.0'	EZ Grip
800203	3.0"	9.5 lbs.	UTS-UTR	Double	14.0'	EZ Grip
800301	3.5"	11.5 lbs.	UTR-UTR	Double	16.5'	EZ Grip
800302	3.5"	11.5 lbs.	UXP-UXP	Custom	16.5'	EZ Grip
800303	3.5"	12 lbs.	UTS-UTR	Custom	16.5'	EZ Grip
800304	3.5"	14 lbs.	UTS-UGPS	Custom	16.5'	EZ Grip
800404	4.0"	20 lbs.	UTS-GP	Custom	18.5'	EZ Grip
800405	4.0"	21 lbs.	UTS-UGPS	Custom	18.5'	EZ Grip
800501	4.5"	25 lbs.	UTS-GP	Custom	22.5'	EZ Grip
800503	4.5"	26 lbs.	UTS-UGPS	Custom	22.5'	EZ Grip
<b>Double Tapered Tubes</b>						
800502	4.5" to 3.5" 30.00		UTS-UTR	Custom	22.5'	EZ Grip
800504	4.5" to 3.5" 30.10		UTS-GP	Custom	22.5'	EZ Grip
800505	4.5" to 3.5" 30.10		UTS-UGPS	Custom	22.5'	EZ Grip
800601	5.0" to 3.5" 39.00		TS-GP	Custom	24.5'	EZ Grip
800701	6.0" to 4.0" 62.00		TS-GP	Custom	28.5'	EZ Grip
<b>Line Control Whisker Poles</b>						
800802		19 lbs.	LC-UTS-UTR		12'-22'	Clear/White*
800800		24 lbs.	LC-UTS-UTR		13'-24'	Clear/White*
800801		32 lbs.	LC-UTS-UTR		15'-27'	Clear/White*
<b>SPECTRA TRIP LINES STANDARD ON ALL POLES</b>						
<b>Options</b>						
800090	Retracting Bridle Option on 3" or Larger UTS Inboard					
800091	Kevlar Patches (per 2 foot section)					**White outer tube with clear coated inner tube standard
<b>Finish Options</b>						
800096	U.V. High Gloss Finish - 2" thru 3-1/2"					*Matterhorn white is standard
800094	U.V. High Gloss Finish - 4" and Larger Poles					
800093	AWLGRIP™ Color Coat on 2" - 3-1/2" Poles					
800089	AWLGRIP™ Color Coat on 4" and Larger Poles					



Shown with optional padded spinnaker pole cover (see inside front cover)

## Padded Spinnaker Pole Covers

Part No.	Model No.
882000	Small - Up to 3" O.D., 14' 6"
882001	Large - Up to 4" O.D., 18' 5"

## CARBON FIBER POLE FINISHES

Forespar offers 3 distinctive pole finishes to chose from:

Our standard "EZ Grip" rough textured finish is the "price conscious" choice. The "High Gloss" UV resistant clear coated glossy poles offers some protection from the elements and also affords a very shiny and good looking pole. The best protection and in some ways the best looking pole is an Awlgrip™ painted pole. A painted pole offers the best protection from the sun while matching any Awlgrip™ color in order to match the mast, deck or any other paint scheme on the boat.

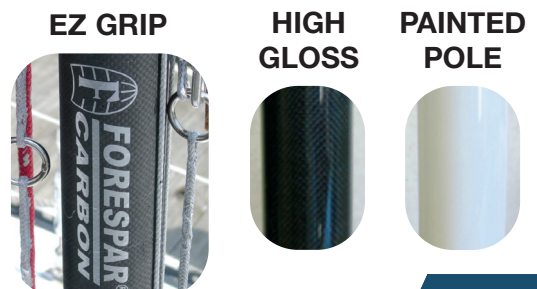

# SPINNAKER POLE ORDER FORM

CUSTOMER NAME: \_\_\_\_\_

DATE: \_\_\_\_\_

SHIPPING ADDRESS: \_\_\_\_\_

PHONE NO./FAX NO.: \_\_\_\_\_

VESSEL BRAND: \_\_\_\_\_

SIZE: \_\_\_\_\_

J DIMENSION: \_\_\_\_\_

PURCHASE ORDER: \_\_\_\_\_

3" IS SUBTRACTED FROM THIS 'J' DIMENSION TO ESTABLISH THE POLE LENGTH.

SIGNATURE/DEPARTMENT/STORE# \_\_\_\_\_

ALUMINUM  CARBON FIBER\*\*

1. UXP - UXP (LATCH END)

2. UTR - UTR (TRIGGER END)

3. UTS - UXP/UTR/UGPS (SOCKET - LATCH/TRIGGER/GRAND PRIX)

4. BRIDLE RETRACTOR OPTION (ON TS END POLES ONLY)

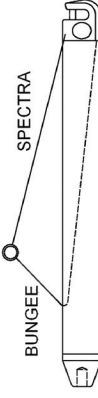
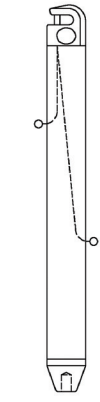
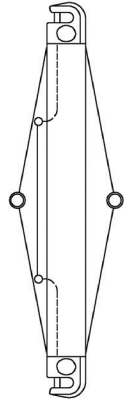
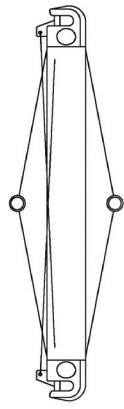

CUSTOM

CONFIGURATIONS

## FINISH SELECTION

STANDARD CLEAR ANODIZED ALUMINUM POLE YES \_\_\_\_\_ NO \_\_\_\_\_

EZ-GRIP FINISH\*\* (STANDARD ON ALL CARBON FIBER POLES)

HIGH GLOSS U.V. CLEAR COAT\*\* (OPTIONAL) YES \_\_\_\_\_ NO \_\_\_\_\_

AWLGRIP WHITE (OPTIONAL) YES \_\_\_\_\_ NO \_\_\_\_\_

KEVLAR PATCHES\*\* YES \_\_\_\_\_ NO \_\_\_\_\_ QTY. \_\_\_\_\_

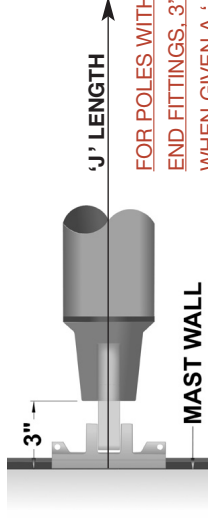

**FOR POLES WITH OUR TS & UTS END FITTINGS, 3" IS SUBTRACTED WHEN GIVEN A 'J' DIMENSION TO ESTABLISH THE POLE LENGTH.**

INBOARD END PATCH LOCATION: **A dim.** \_\_\_\_\_ **B dim.** \_\_\_\_\_ (SEE DIAGRAM BELOW)

POLE DIAMETER: \_\_\_\_\_ INBOARD END: \_\_\_\_\_ OUTBOARD END: \_\_\_\_\_

THE INFORMATION (DIMENSIONS, COLOR, ETC.) PROVIDED ON THIS FORM BY YOU, THE CUSTOMER, IS WHAT WILL BE BUILT. ANY CHANGES TO ANY PART OF THIS FORM, OR CANCELLATION AFTER IT IS RECEIVED BY FORESPAR® MAY INCUR ADDITIONAL CHARGES OR MAY NOT BE POSSIBLE AFTER CUSTOM CONSTRUCTION BEGINS. THE LEAD TIME BEGINS UPON RECEIPT AND ACKNOWLEDGMENT OF THIS FORM BY FORESPAR®.

**Please check YES or NO, and use feet and inches for dimensional inputs.**

**Vessel Brand and Size are very important.**

\*\* Denotes carbon fiber pole options



**FORESPAR®**  
**SPINNAKER POLES**

22322 GILBERTO, RANCHO SANTA MARGARITA, CA 92688

PHONE (949)858-8820 FAX (949)858-0505 EMAIL sales@forespar.com

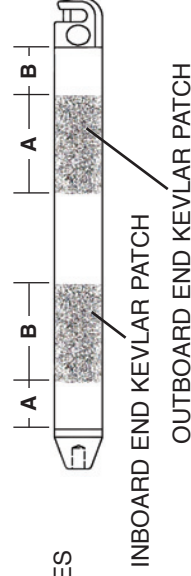

KEVLAR PATCHES MUST START AT LEAST 2 INCHES FROM THE END OF THE TUBE TO ALLOW FOR FASTENERS. THE WIDTH OF THE PATCHES MUST BE IN 2 FOOT INCREMENTS.

INBOARD END KEVLAR PATCH

OUTBOARD END KEVLAR PATCH



# REACHING STRUTS, LIGHTNING MASTER™

## SELF-LATCHING

These struts feature the easy-latching inboard fitting which easily and quickly snaps onto the mast ring. Use of our stainless steel **PE-3SF** or **PE-3SC** mast pad eyes is recommended for proper fit.



Part No.	Model No.	Kit Length & Weight	Dia.	Mast Fitting
341000	RS-200-UXP	5'7 lbs.	2"	PE-3SF or PE-3SC
341001	RS-250-UXP	6'9 lbs.	2 1/2"	PE-3SF or PE-3SC
341002	RS-300-UXP	7'10 lbs.	3"	PE-3SF or PE-3SC

## REACHING STRUTS AVAILABLE IN CARBON FIBER

## AUTOMATIC LOCKING

This series of strut features our special socket-type end that automatically locks onto the toggle-pin mast fitting with an easy push on the strut. A simple release lever allows the strut to be quickly removed. This strut is especially valuable in competitive racing situations. The **TMP** mast fittings are required.



Part No.	Model No.	Kit Length & Weight	Dia.
343000	RS-300-TS	7'11 lbs.	3"
343001	RS-400-TS	9'17 lbs.	4"



Part No.	Description
343002	Aluminum
343010	Stainless Steel

## STRUT END FITTINGS

The RSO-200 accepts up to 3/8" line while the RSO-300 and RSO-400 accept up to 5/8" line.

Part No.	Model No.	Strut End	Fits Tube I.D.
349000	RSO-200-EF	Outboard	1.870"
349001	RSO-250-EF	Outboard	2.334"
349002	RSO-300-EF	Outboard	2.835"
349003	RSO-400-EF	Outboard	3.750"
304050	UXP-200-EF	Inboard	1.870"
304051	UXP-250-EF	Inboard	2.334"
304052	UXP-300-EF	Inboard	2.835"
309028	TS-300-EF	Inboard	2.835"
405006	TS-400-EF	Inboard	3.750"

## LIGHTNING MASTER™ STATIC DISSIPATORS

**Lightning Master™ Static Dissipators** lower the exposure to a direct lightning strike by controlling the conditions which trigger direct strikes (i.e. they reduce the build-up of static ground charge and retard the formation of the ion "streamers" which complete the path for a lightning strike).

The Dissipator employs the point-discharge principle to continually leak off the lightning causing ground potential in low amperages over a long period of time instead of the short duration, high amperage discharge occurring with a lightning strike.

This is the same technology from the same manufacturer which is successfully employed to protect commercial broadcast and television towers from direct lightning strikes. This lightweight (5.2 oz.) 21" long Dissipator mounts to the masthead and extends vertically above all other masthead equipment.

We do not claim that this product is 100% effective in preventing a lightning strike. At the present collective level of understanding of the lightning phenomenon, no one can make that claim. This product does control the causes of lightning strikes and thereby reduces the incidence of direct strikes.

## Works Well for Power Boats & Sailboats!

Part No.	Description
151100	Lightning Master™ Static Dissipator

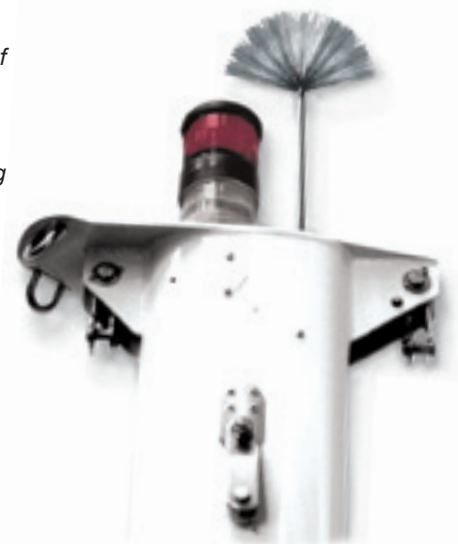

Lightning Master™ is the trade mark of the Lightning Master Corporation whose products are protected by U.S. patent.

# HOYT JIB BOOM™ SYSTEM

## HOYT JIB BOOM™

As your boat bears off downwind, and the sheets are eased, the **Hoyt Jib Boom™** maintains precise control of the jib's leach. This results in remarkable performance improvement and ease of handling.

**Proven on over 1,000 sailboats and numerous trans-oceanic passages**

- Leach twist perfectly trimmed downwind
- Self tacking upwind
- Self vanging downwind
- Up and downwind jib control based on a simple & effective principle

*"The Hoyt Jib Boom™ is one of the best cruising innovations I have seen or used".*  
Ken Read  
Vice Pres. North Sails



- Sail more easily and more efficiently!

- White Powder Coated (base only)

- Perfect trim of your 100% self-tacking jib Wing and Wing downwind



"Hundreds of Island Packets with these **Hoyt Boom™** staysail rigs have now logged countless miles cruising worldwide in all varieties of conditions. I'd be hard pressed to improve on any aspect of this setup and would heartily recommend it to all cruising sailors".

Bob Johnson  
President/CEO Island Packet Yachts



Universal swivel insures proper leach twist.



The typical base placement (center of the pedestal base) is 10% aft of the headstay. This is not a critical location, but rather a "Rule of Thumb". Various obstacles can obstruct the pedestal base position.

All knuckles are bent to 57 degrees. All pedestals are set at 23 degrees. All angles are calculated on a perfectly flat and level deck. Wedges will be required on many installations to make up for deck camber. A universal black molded urethane wedge which can be cut to fit is available from **Forespar®**

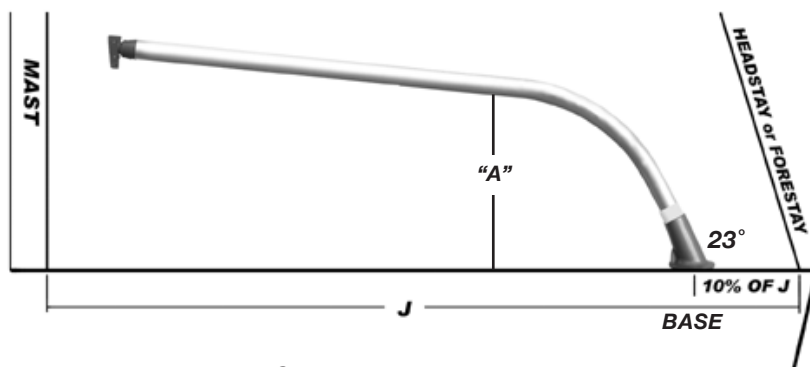

Part#	Model No.	Tube Dia	Weight	Knuckle Length	Boom Tube Length	Suggested Maximum J	Yacht LOA	Base Dia	"A"
313101	250	2.5" OD	16lbs	2.25"	6'	10'	25' - 29'	7"	14"
313102	300	3.0" OD	24lbs	2.50"	11'	13'	30' - 35'	7-3/4"	17"
313103	350	3.5" OD	37lbs	2.75"	13'	17'	35' - 42'	8-3/4"	21"
313155	Universal Wedge								

## YACHT ROD™

### *The High Performance Spring-Loaded Mechanical Boom Vang*

Precision design in three sizes. Excellent vang/boom support for performance cruising and racing. White powder coated aluminum & polished stainless steel. Supplied with spectra cable ready to add your tackle system. Your 4:1 equals 8:1 when installed on **Yacht Rod™**. Can be led to small winch for additional power. Spring return holds boom. Brackets for mast and boom sold separately. Mast and boom fittings are listed below. **Caution: Oversheeting or leaning heavily on aft end of boom can bend the boom or the Yacht Rod™. The main halyard shackle should be snapped to the outboard boom end, in port, to prevent damage to the Yacht Rod™.**



#### FEATURES:

- *Eliminates need for boom topping lift*
- *Supports boom in light air and when reefing and lowering the mainsail*
- *Faster than hydraulics – No messy hydraulics to leak*
- *More efficient than conventional tackles*
- *Tubing is white coated anodized 6061-T6 aluminum and electropolished 316 stainless steel*
- *Precision machined 6061-T6 aluminum clevis ends, sheaves and Nylatron® bearings*
- *Precipitation hardened stainless steel spring with fast-pin adjustment — rated for over 1 million compressions*
- *No gas spring to lose its charge*



**CUSTOM OEM  
VANGS AVAILABLE**



**“FOR RACING OR CRUISING”**

**Note of Caution:** Furling booms weigh as much as 3 times the weight of standard booms. Standard vang spring will not support their weight.

## YACHT ROD™ MAST & BOOM FITTINGS

	YR-M	YR-L	YR-XL
Stroke	7"	11-1/2"	11-1/2"
Adjustable Length			
Pin to Pin (min.)	58 1/2"	66 1/2"	79 1/2"
Pin to Pin (max.)	70 1/2"	80"	93"
Adjustable distance	12"	13-1/2"	13-1/2"
Pin Size	1/2"	5/8"	5/8"
Jaw Width	3/8"	11/16"	11/16"
Weight	9.8 lbs	17 lbs	19 lbs
Max. Return Force	600 lbs	1450 lbs	1450 lbs



YR-M Mast Fitting



YR-M Boom Fitting

### Part No. Model No./Description:

352003	Boom fitting for YR-M
352103	Boom fitting for YR-L & YR-XL
352005	Mast fitting for YR-M
352104	Mast fitting for YR-L & YR-XL
352007	Harken 8:1 Tackle YR-M
352130	Harken 8:1 Tackle YR-L
352131	Harken 8:1 Tackle YR-XL

Part No.	Model No./Description:
352000	YR Medium Yacht Rod for boats 34-40'
352100	YR Large Yacht Rod for boats 41-45'
352101	YR X-Large Yacht Rod for boats 46-55'

### YR-L & XLG Mast Fitting

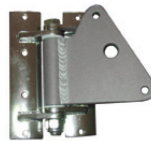

### YR-L & XLG Boom Fitting



Part No.	Package	Max. LOA	Includes
352050	1	40	YR-M Vang YR-M Boom Fitting YR-M Mast Fitting Harken Blocks & Tackle
352160	2	45	YR-LG Vang YR-LG Boom Fitting YR-LG Mast Fitting Harken Blocks & Tackle
352165	3	55	YR-XLG Vang YR-XLG Boom Fitting YR-XLG Mast Fitting Harken Blocks & Tackle



## TECH. TIPS - ABOUT YACHT RODS / BOOM VANGS

Forespar® makes three sizes of spring loaded boom vang for boats starting around 30 feet and up to about 55 feet. These units are rugged, a good value, and have many thousands of ocean miles under hundreds of boats all over the world. We do not offer the most purchase or have any "locks" or fancy stuff. These are work horses designed to do the job on a general cruising boat or club racer. They will work very effectively if installed correctly and not abused.

Some basic points to remember:

The boom must be fixed, non-rotating and non-sliding on the mast. Roller booms or sliding goosenecks will not work with any rigid vang. The boom fitting or the upper vang head will fail if the boom can roll.

The minimum angle from the boom should not be less than 30 deg. and no more than 45 deg. Lesser or greater angles increase the compressive load beyond what a spring-loaded vang can handle. Hydraulics is the only answer beyond these angles.

Yacht Rods do not "lift" the boom. Only hydraulics can do that. These do take the place of a topping lift. They will hold the boom up while dropping sails or reefing. Properly set up, they will keep the boom level when the main is furled.

Do not attempt using a standard spring-loaded vang with an in-boom furling system. These furling units are far heavier than a standard boom and these vangs are not suited for this type of boom.

The "stroke" is the total maximum compressed travel of the spring/piston. Once the spring bottoms out, the unit will fail if further compressive force is applied.

We offer a minimum of 7" on the medium Yacht Rod and 11-1/2" on the large and extra large units. This should be

plenty of travel. If, on an average 40' cruiser, they need to "vang" the main down more than 7", the sail is cut wrong!

We make mast and boom brackets to fit our ends. We require that they be used. They must handle a tremendous compression force and still articulate in line with the boom. They are every bit as critical as the booms gooseneck. The boom fitting must fit snugly to the vang end and "spread" the load on the boom. This fitting sees compression and tension. The boom attachment must be capable of handling these forces without kinking the boom. A lot of race boats loose their booms due to failure at the vang fitting.

Rigid vangs can rattle, squeak, or make other noises under sail. They all do to some degree. We cannot guarantee ours will be completely quiet, but from the hundreds of installations in the field, we are not hearing of any major noise problems. Do not oil these! The oil will simply flow out and end up on deck. Keep them clean by flushing with fresh water periodically. No other maintenance should be needed other than watching for worn line, dents or bends. Do not use a unit that has been damaged or over-compressed. Common care should keep the Yacht Rod working for many years and nautical miles.

### SIZING YACHT ROD BOOM VANGS

Choosing the correct size rigid vang requires the following information:

Distance from mast fitting to boom fitting at the proper angle from the boom per the previous spec sheet. This will tell you what length requirements you have for using the "pin to pin" dimensions on the Yacht Rod size chart. Note that it is possible to have a low boom on a large boat that makes this dimension inaccurate. Be sure to check angle and length. Be sure you do not have any obstructions (hatches, vents,

cabin tops) in the way of the Yacht Rod's arc of movement. Remember that it will need clearance through 180 degrees of movement from side to side.

Check above dimensions against the catalog's boat size recommendations. If you are close to the maximum, you may need to go up a size to support your boom and sails weight at rest. (Furled) Do not undersize!

Install mast fitting as low as possible on aft centerline of mast.

Install boom fitting to get proper angle per previous specs sheet. You may want to clamp the boom fitting in place first, before you drill any holes; to be sure it is in the correct position. This way, you can ease the weight of the boom and furled main sail onto the unit to find out how much the spring will be compressed at rest.

Adjust the cross pin as needed being sure the spring is between the pin and the inner piston tube. Do not set the pin through the spring!

Whenever the sail is furled, it is best to set the main halyard to the outboard end of the boom to support the booms weight. In this way, the Yacht Rod spring will not take a "set" from being compressed the whole time the boat is not in use.

Basic sizing:

34-40 feet- Yacht Rod Medium #352000 or package #352050  
41-45 feet- Yacht Rod Large #352100 or package #352160  
46-55 feet- Yacht Rod Extra-Large #352101 or package #352165  
Packages include the mast and boom brackets and tackle.

**Forespar®** now offers two mast light systems of superior quality. Model **ML-1** is a deck light designed primarily for installation on the mast just below the spreaders. Model **ML-2** is a combination deck-bow light with separate switching, to be mounted on the forward part of the mast.

**ML-1 & ML-2** lights feature a durable molded polymer housing assembly with a readily adaptable wraparound mounting apron to accommodate virtually any mast surface curvature. For 12 V systems. Replacement bulbs are available from **Forespar®** and most marine dealers.



## SPREADER/DECK LIGHT — ML-1

- Lightweight — Rugged Composite Material
- Adaptable to Mast Radius for Ease in Mounting
- 20W Easily Replaceable Halogen Type Bulb 1.4 amps
- Weighs 4 oz. — Measures 3-5/8" Vertically
- Provided with 6" of Twin-Lead Wire
- New Molded Body
- Available in black finish only

Part No.	Model No.
131000	ML-1
132035	Bulb
132009	Replacement bottom ring (Twist lock)
132006	Replacement bulb (Threaded old style)



## COMBINATION DECK/BOW LIGHT — ML-2

- Bow Light Meets Coast Guard Requirements for Yachts Up to 65' LOA\*
- Separate Switching
- 10 Watt Bow Light Bulb Is Easily Replaceable (WN-211) .8 amps
- Deck Light Features Identical to ML-1
- Provided with 6" of Triple-Lead Wire
- Weighs 7 oz. — Measures 5-3/4" Vertically
- New Molded Body
- Available in black finish only
- Mast Light Chafe Guard Will Also Work With Aqua Signal Model 254047-7 Combo Light

This top selling light has been completely retooled to provide better access for bulb replacement. At the same time, the decklight/bulb assembly has been greatly improved with a new prismatic reflector for enhanced deck illumination.

Part No.	Model No.
132000	ML-2
132025	WN-211 Top Bulb
132035	Bottom Bulb (New)
132009	Replacement bottom ring
132200	Stainless Steel Chafe Guard
132041	Complete top clear lense
132006	Replacement Bulb (Threaded old style)



**S/S LIGHT GUARD**  
(SOLD SEPARATELY, KEEP LINES FROM SNAGGING WHILE PROTECTING FITTINGS)



\*Copy of certification report available upon request from **Forespar®**.

SEE REPLACEMENT PARTS PAGE

# OVERBOARD SAFETY EQUIPMENT

## FLAG TUBE — OP-FT

To secure the flag on the overboard pole to the backstay or along the lifeline, our polyvinyl flag tube is superior to fabric flag-boots. Offering longer life and a faster release of overboard pole. Comes complete with fasteners and simple instructions. Maximum wire size = 3/8 in.



Part No.	Model No.
202013	OP-FT

## OVERBOARD POLE HOLDER — 300-M

The Railfast® overboard pole holder holds the base of the pole. Easily mounted to the stern rail, close to the horseshoe bracket, it helps provide a complete safety system—with all man-overboard items located in close proximity for speedy deployment when time is of the essence. This unit is made of stainless steel and corrosion proof nylon, and comes with all mounting hardware.



Part No.	Model No.
156003	300-M-1" Rail
156023	300-M-1-1/4" Rail



## TECH. TIPS - ABOUT THE OVERBOARD POLES

"Man Overboard"! Two of the most feared words ever to be heard on board a boat. For the many thousands of years people have plied the seas and to this day this one call can bring chills to the most seasoned sailor. These two words can cause panic or instant reaction, depending on how prepared the crew is and how much practice has been done in advance of the incident.

Preparation is the key. A crew that has practiced and prepared should not panic and be able to perform the needed functions for a successful retrieval. Some of the preparations are somewhat unique to your style boat. Others are time honored, basic methods that have been published dozens of times in magazines, books and flyers. It's the "unique to your boat" part that can be a problem. This is where the practice and preparation comes into play to make sure everyone knows his or her place and job during the procedure.

As mentioned, there are the accepted basics of a man overboard drill. The "quick stop" method is probably the most uniformly accepted "basic" maneuver used by sailors today. It simply makes sense to stop the boat as quickly as possible and return to the victim as fast as possible. Simple to visualize but not as easy to do! When you have everything flying, (main, staysail, jib or genoa, possibly a spinnaker) stopping the boat quickly is a bit harder than you think. Imagine if you're running before the trades in 20 knots plus with a 6 to 8 foot chop on top of a 20-foot ground swell. How do you stop the boat!

It is a fact that a boat moving at only 3 knots will be 50 feet away from a person in the water in only 10 seconds. 50 feet may not sound very far but in any chop at all, the person may as well be a mile away. Try finding a coconut in a chop. A person's head is not much bigger! Even with flotation and wild arm waving, if there is any kind of seas up, it's going to be very hard to keep a visual on the person, especially while trying to stop the boat, drop sails (remember that spinnaker!) and sail or power back. Now do it all at night!

This is why a Man Overboard Pole (or, to be politically correct, a Person Overboard Pole) is a vital component in the safety package arsenal on any boat going offshore. An overboard pole puts a flag (code flag "O") a minimum of 9 feet off the water. This flag also has reflective tape for better nighttime visibility. With the overboard pole, you can see the flag/pole at a much farther distance and in rough seas far better than just a person's head and flailing arms. Used with a proper water light (automatic strobe light) the crew overboard has a far better chance of being found, assuming all the gear goes into the water within a few seconds of the person going overboard. Remember the 50 feet in 10 seconds at only 3 knots of boat speed. Every second counts!

Storage or placement of the pole is important. They come in three pieces (for easy shipping) and should be assembled and ready to deploy at all times. You don't want to have someone dive below to find the overboard pole, put it together and bring it on deck in an emergency! It should be rigged in such a manner as to be immediately deployable with a minimum of fuss. Every crewmember on board should fully understand how to deploy the pole. You never know who will be closest to the pole when an event happens. If only one or two people on board are the "overboard pole deployment people", what happens when they are off watch or below eating or in the head when you go overboard. Not a pretty thought.

The overboard pole is designed to be stored vertically up a backstay or mizzen shroud or along the lifelines horizontally. The bottom and the top of the poles need to be supported so they do not whip themselves to pieces in a seaway. Poles that are placed in rod holders or PVC tubes and not supported at the top can fracture with the constant leverage and motion. Also, the storage "mounts" must allow the pole to be deployed quickly without the need to untie or disconnect anything. Proper mounts and upper "flag tubes" are made and available for this purpose. They allow the pole to simply be lifted and dropped over the side. There are also safety packages available that not

only mount the pole but also house the other safety items (water light, horseshoe buoy, whistle, drogue, etc.) as well.

Now back to the "unique to your boat" part from earlier. There are hundreds of different styles of boats, all with different cockpit arrangements, stern shapes, dodgers and biminis, boom gallows, railings, mizzen mast, helm stations and any number of winch placements, railings and push pits. All this can change your particular requirements in mounting and deploying the pole and the rest of the overboard equipment. This is why, in recent years, the Life Sling has become so popular.

Let's consider the Life Sling for a moment. It is very good at what it was designed for—retrieving a person in the water. What it lacks is the ability to find the person to retrieve! If you do the "loop-to-loop" that they instruct you to do but the person is not within that "loop", what then? How do you find them? We are back to the overboard pole! Used with the Life Sling, an overboard pole allows you to find the person and loop around them while dragging the sling. The overboard pole gives you a visual reference that you do not have with the Life Sling alone.

Many offshore race categories require a man overboard pole. The Trans-Pacific Yacht Club (for the Transpac race) recognizes this need and requires a Man Overboard Pole on every boat in the Transpac race. Many other offshore races also require overboard poles.

For all the reasons mentioned above, the overboard pole is an inexpensive life-saving tool that should be part of any boat's safety equipment. Going offshore or just down the coast, the overboard pole should be ready to deploy in a moments notice. Even with a Life Sling or other equipment (horseshoe buoy, ring buoy, rescue throw-ropes, PFD's, etc.) Without one, you will be hard pressed to find the person in the water to retrieve.

## OVERBOARD GEAR NEEDS TO BE DEPLOYED QUICKLY...



... Because, at only **3 knots** ...

... the person will be **50 feet** away in **10 seconds**, and ...

... in waves, the person will lose sight of the horseshoe buoy without an overboard pole!!

## OVERBOARD POLES — OP-120/150

**Forespar**® Man Overboard Poles are approved by both I.S.A.F. and Transpac Y.C. for offshore racing. These poles are constructed of the finest materials and reflect modern design and quality workmanship. The strong fiberglass shafts feature a highly visible yellow coating. The red and yellow flags are made of long lasting Dacron with a batten sewn in place to hold the flag in an open position. Now includes reflective tape to aid in night location.

**Forespar**® offers a special bright orange float which is made of a high impact, polyethylene jacket filled with closed-cell polyurethane foam. The float is slotted on the OP 120/150 model so it easily fits close to the backstay or life lines.

All poles are two-piece and feature a unique top shaft that can be custom sized by the user resulting in an overall pole length ranging from 11.5 to 15 ft. An epoxy kit is provided with each unit and no cutting is necessary. Simply telescope the top shaft to length desired and epoxy in place. A non-corrosive joining sleeve is standard to allow disassembly of the top shaft from the float for easy storage. The flag is included with Overboard Poles. Outside diameter of float is 4.25 inches.



### DIMENSIONS

Part No.	Model No.	Overall Length		Butt to Top of Float	Weight	Top Half	
		Minimum	Maximum			Minimum	Maximum
202018	OP-120/150	142 in.	176 -1/2 in.	64 in.	8 lbs.	78 in.	112-1/2 in.
202020	Top Pole Complete with Flag						
202026	Replacement Flag						

**WARRANTY RETURNS BASED ON UV EXPOSURE LIMITED TO 12 MONTHS**

## STERN TUBE OVERBOARD POLES

Functionally the same as model OP-120 overboard pole, the OPST is designed for boats with stern tubes.

Outside diameter of float is 3.25 inches.

Constructed from the same fine materials as our 'standard' poles.



### DIMENSIONS

Part No.	Model No.	Overall Length		Butt to Top of Float	Weight	Top Half	
		Minimum	Maximum			Minimum	Maximum
202019	OPST	143 in	178 in	65-1/4 in	8 lbs.	78-1/2 in.	112-1/2 in.

**WARRANTY RETURNS BASED ON UV EXPOSURE LIMITED TO 12 MONTHS**

# STROBE LIGHTS, PERSONAL & FLOATING

## FLOATING STROBE WATER LIGHT — WL-1

Recent intense technological developments in the camera industry enable **Forespar®** to bring you this advanced strobe light at a significantly lower price.

Built to meet Code of Federal Regulations sub part 161.010; this rugged water light produces brilliant omni directional (360 degrees) strobe flashes automatically when thrown overboard and is visible for miles at sea. When used with a 6 volt alkaline lantern battery (not included) it will flash at the U.S.C.G. required rate for over 52 hours and will still flash at least every 2 seconds after 7 days of continuous operation (meets U.S.C.G. requirements—46 CFR-161.010). A stainless steel mounting bracket is included. Dimensions are 11-1/2" long, and 4" maximum diameter, 1.85 lbs.

### U.S.C.G. Approval #161.010/20/0

Part No.	Model No.
205102	WL-1
205130	Replacement Strobe

WARRANTY RETURNS BASED ON UV EXPOSURE LIMITED TO 12 MONTHS 



## PERSONAL RESCUE LIGHT RL-2

**Forespar®**'s new approved personal strobe flasher should be an essential part of every yachtsman's safety gear. Meets U.S.C.G. 161.012 when powered by an alkaline "C" battery replaced annually. Batteries are not included. Waterproof to 120 feet Has a Velcro strap for attachment to upper arm or safety harness. Measures approx. 5" high, weighs only 5 oz. & flashes for over 24 hours.



Part No.	Model No.
202102	RL-2

## PERSONAL RESCUE LIGHT RL-SOLAS

The **RL-SOLAS** meets both U.S.C.G. (46 CFR 161.012) and S.O.L.A.S. (Saving of Life at Sea) requirements only when powered by a 3v lithium battery (included). S.O.L.A.S. standards are set by the International Marine Organization (I.M.O.) to which 176 countries are signatories. The 3V lithium battery has a 10 year shelf life and is also available from **Forespar®**. Similar in performance to the RL-2.

### U.S.C.G. Approval #161.012/12/0, #161.112/4/0 and SOLAS #74/83



Part No.	Model No.
202150	RL-SOLAS
202151	LB-3 Lithium battery for RL-SOLAS

WARRANTY RETURNS BASED ON UV EXPOSURE LIMITED TO 12 MONTHS 



# LANOCOTE®, MARELON® CLEATS & CHOCKS

## LANOCOTE®

**HOW DOES LANOCOTE® WORK?** LanoCote® works on these five basic principals: displaces water, absorbs corrosion, forms moisture barrier, penetrates and has high lubricity. LanoCote® prevents dissimilar metal galvanization. LanoCote® is extremely effective in preventing and stopping corrosion on all types of metals under all environmental conditions. Formulated to withstand salt water marine conditions, LanoCote® is particularly useful in preventing thread seizure due to all types of corrosion on boats and machinery. Applied during assembly, LanoCote® will greatly assist in easy dismantling years later. An example would be anchor shackles which are regularly immersed in salt water. LanoCote® also combats galvanization where dissimilar metals are fastened together, such as stainless steel fittings on alloy masts etc.

## CHOICE OF MARINE PROFESSIONALS

## LONG TERM CORROSION CONTROL



Part No.	Model	Offered In
770001	LanoCote® 4 oz. Jar	12 Packs Only
770002	LanoCote® 7 oz. Aerosol Spray Can	12 Packs Only
770003	LanoCote® 16 oz. Jar	Sold as Each

LanoCote® is a Registered Trademark of Lanocote, Inc.

## ASSORTED CLEATS

Molded from high-strength Marelon®, Forespar's cleats have been thoroughly tested by independent laboratories and manufacturers of yachts and power boats all over the world. Their strength, light weight and low cost have contributed to their increased use in the marine industry. **The use of Marelon® allows our cleats to take up the curve of a deck without breaking, while maintaining strength and resisting abrasion — will not soften on hot days or freeze in winter.**

### 3" - 8" CLEATS



Part No.	Model No.	Hole Dia.	Size
941018	MF 761/3	5/32"	3"
941016	MF 762/4	3/16"	4"
941013	MF 763/5	3/16"	5"
941014	MF 764/6.5	1/4"	6.5"
941015	MF 765/8	1/4"	8"

### 5" & 6" CLEAT



Part No.	Model No.	Hole Dia.
941000	MF 751/5	3/16"
941001	MF 751/6	3/16"

### LOW PROFILE 6" CLEAT



Part No.	Model No.	Hole Dia.
941006	MF 766/6	1/4"

## LINE CHOCKS — 3-1/2" & 6"



Part No.	Model No.	Hole Ctrs.	Hole Dia.
950001	MF 755	3-1/2"	3/16"
950000	MF 770	6"	1/4"

## EXIT BOX

This new exit box is made for use with the new high-tech fibers. Forespar® uses this new exit on all trip lines and topping lifts. It is suitable for aluminum and ideal for carbon fiber poles as there is no metal to metal contact to promote corrosion. The axles are stainless steel molded into a strong Marelon® cheek with no moving parts. Flange size: 3-1/4" L X 7/8" W  
Cut-out size: 2" X 11/16"  
Maximum line size: 1/4"  
Uses two 3/16" flat head fasteners.



Part No.	Model
030016	Marelon® Exit Box

# JIB ROLLERS & SHACKLE GUARDS

## SR-3 Sail Saver™ Jib Roller

These light weight, easily installed rollers can be used on the spreader tips or life lines to help skirt the foot of the jib. Sail Savers can also be used on backstays of catamarans or other boats with large roached mainsails. Center hole is 3/16" and can be drilled out to 3/8" maximum.

Simple installation with a small screw driver. The unique locking collar is held in place with a small stainless steel set screw so there is no need for rigging tape or wire. The two halves "mate" (slide them together and they lock) and two clips are snapped on for added safety. Quick and simple. Easy to put on and also easy to remove. Sold in pairs.

### Part No.

210020

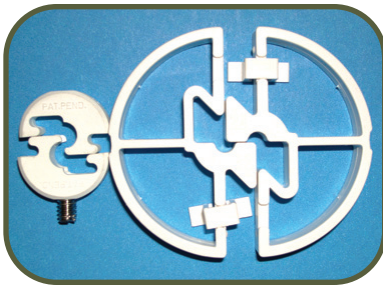

Locking collar with set screw.

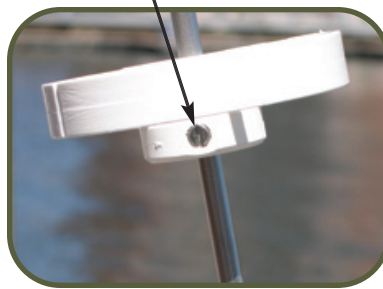

## SHACKLE GUARDS

Place a protective buffer between the spinnaker pole ends and your after-guy shackle. Made of high-strength polyethylene, these tough polymer guards are UV inhibited for long life. Shackle Guards can also be used on lifelines to skirt genoas. Sold individually.

### Part No. Model No. Size

300006	SG-1 White	2-1/4" Dia. X 3/8" ID
300007	SG-2 White	2-1/4" Dia. X 1/2" ID
300008	SG-3 White	3" Dia. X 1/2" ID
300009	SG-4 White	3" Dia. X 5/8" ID
300010	SG-5 White	3" Dia. X 3/4" ID
300085	SG-1 Red	2-1/4" Dia. X 3/8" ID
300086	SG-2 Red	2-1/4" Dia. X 1/2" ID
300087	SG-3 Red	3" Dia. X 1/2" ID
300088	SG-4 Red	3" Dia. X 5/8" ID
300089	SG-5 Red	3" Dia. X 3/4" ID
300090	SG-1 Green	2-1/4" Dia. X 3/8" ID
300091	SG-2 Green	2-1/4" Dia. X 1/2" ID
300092	SG-3 Green	3" Dia. X 1/2" ID
300093	SG-4 Green	3" Dia. X 5/8" ID
300094	SG-5 Green	3" Dia. X 3/4" ID

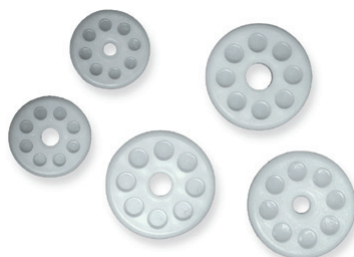

## JIB ROLLER — SR-2

Jib rollers for wire sizes 3/16" to 3/8". Extend the life of your genoa by reducing chafe on the spreader tips.

Jib rollers can also be used on lifelines for helping pass foot of jib over stanchions. Sold in pairs.

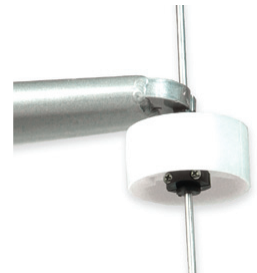

### Part No. Model No. Wire Size

210003	SR-2 (pr.)	Accepts wire 3/16" to 3/8"
--------	------------	----------------------------

## TURNBUCKLE COVER

Deluxe aluminum turnbuckle covers give a fine yacht the "finished" look. Functional (keeps sheets from snagging on turnbuckle clevis pins) and durable, the turnbuckle covers come in three sizes to handle rigging from 7/32" to 1/2" wire diameter. They are available in a white finish or clear anodized (silver) aluminum finish. The bases (bottom) come square and can be notched (to fit over chain plates) or cut to match your deck/shroud angle. Sold individually.

**Small**-(1-1/2" diameter tubes) for 7/32", 1/4" and 9/32" wire sizes.

#210013 Anodized

#210010 White

Length - 22"

**Medium**-(2" diameter tubes) for 5/16" and 3/8" wire sizes.

#210014 Anodized

#210011 White

Length - 26"

**Large**-(2-1/2" diameter tubes) for 7/16" and 1/2" wire sizes.

#210015 Anodized

#210012 White

Length - 36"



## NASH MARINE LABELS

These popular label sets are great for any racer or cruiser. Add safety and organization to your above and below deck systems. Remember, not everyone on board knows your boat as well as you do. All labels are self-adhesive, vinyl plastic, waterproof and won't fade. Perfect for flat, round or irregular surfaces of metal, fiberglass or paint.

### SAILBOAT LABELS

**201**

FOREGUY	MAIN HALYARD	BOOM LIFT
	JIB HALYARD	
	STAYSAIL HAL'YD	
	SPINNAKER HAL'YD	
OUTHAUL	TOPPING LIFT	DOWNHAUL
	CUNNINGHAM	
	BOOM VANG	
	MAIN SHEET	

**202**

TRAVELER	TACK REEF	JIB SHEET
	CLEW REEF	
	JIB WIRE	
	JIB CLOTH	
TRAVELER	JIB FURLER	JIB SHEET
	CENTERBOARD	
	BARBER HAUL	
	BARBER HAUL	

**203**

1	1
2	2
3	3
4	4
5	5
6	6
7	7
8	8
9	9
10	10
11	11
12	12
13	13
14	14

**204**

-10-
-9-
-8-
-7-
-6-
-5-
-4-
-3-
-2-
-1-
-0-

**206**

RUNNING BACK	BABYSTAY	FORESTAY
	#2 JIB HALYARD	
	#2 SPINN. HAL'YD	
	#2 CLEW REEF	
RUNNING BACK	SLAB REEF	BACKSTAY
	SHOOTER SHEET	
	BUTT LIFT	
	BUTT DOWNHAUL	

**214**

STAYSAIL FURL	#1 TACK REEF	MAIN HALYARD
	#2 TACK REEF	
	#3 TACK REEF	
JIB FURLER	#1 CLEW REEF	MAIN SHEET
	#2 CLEW REEF	
	#3 CLEW REEF	
	STAYS'L SHEET	
	STAYS'L SHEET	

**207**

### MECHANICAL LABELS

**208**

GASOLINE	WATER	WATER	PROPANE
	WATER	WATER	
	DIESEL	DIESEL	
GASOLINE	FUEL	FUEL	PROPANE
	ENGINE OIL	WATER OVERFLOW	
KEROSENE	AIR	VACUUM	PROPANE
	PUMP OUT	HOT WATER	ALCOHOL
	HOLDING	SUMP	

**209**

BILGE PUMP OUTLET	COCKPIT DRAIN
GALLEY SINK DRAIN	COCKPIT DRAIN
HEAD SINK DRAIN	ICE BOX DRAIN
FWD TOILET INTAKE	FWD TOILET OUTLET
AFT TOILET INTAKE	AFT TOILET OUTLET
PROPANE DRAIN	BRINEWATER OUTLET
BAIT WELL INTAKE	WASH DOWN INTAKE
RAIN WATER INLET	SALT WATER INTAKE
HOLDING-TANK OUTLET	ENGINE COOLING INTAKE
ANCHOR LOCKER DRAIN	GENERATOR COOLING INTAKE
AIR COOLING INTAKE	REFRIG. COOLING INTAKE

**210**

FORWARD	KEEP OPEN	KEEP CLOSED
FORWARD	KEEP OPEN	KEEP CLOSED
PORT	STARBOARD	KEEP CLOSED
PORT	STARBOARD	KEEP CLOSED
ON	FEEDWATER (SEAWATER)	KEEP CLOSED
OFF	PRE-FILTER	
AFT	PRODUCT WATER	Y-VALVE
AFT	BRINEWATER	

**211**

LUBE OIL FILTER	FUEL BLEED	FRESH WATER FILL
WATER OVERFLOW	FUEL BLEED	
RAW WATER STRAINER	FUEL BLEED	
INJECTOR OIL FILL	FUEL BLEED	
INJECTOR OIL DRAIN	FUEL BLEED PUMP	OIL PRESSURE ALARM
FUEL FILTER	ZINC FINGER	OIL PUMP-OUT
OIL FILTER	ZINC FINGER	
OIL COOLER	ZINC FINGER	

**212**

DOCK POWER	12v D.C.	HOUSE BANK
120v A.C.	12v D.C.	
240v A.C.	POSITIVE (+)	
ALTERNATOR	POSITIVE (+)	
INVERTER	NEGATIVE (-)	START BANK
CHARGER	NEGATIVE (-)	
BATTERY MONITOR	MOTOR GENERATOR	
SOLAR PANEL	WIND GENERATOR	BATTERY 4

### ELECTRICAL LABELS 213

NAVIGATION DISPLAY	GPS	VHF RADIO	WEATHERFAX RECEIVER
TELEVISION	RADAR	HAM/SSB RADIO	
	LORAN	AM/FM RECEIVER	
SMART REGULATOR	CHART PLOTTER	CD PLAYER	MICROWAVE OVEN
	AUTOPILOT	CASSETTE PLAYER	
	WATER MAKER	KNOTMETER	
	DESKTOP COMPUTER	DEPTH SOUNDER	PROPANE VALVE
	LAPTOP COMPUTER	FISHFINDER	

### SAFETY LABELS 205

PACKAGED FOOD	LIFE JACKETS	FRESH WATER
	FIRE EXTINGUISHER	
	FIRST AID KIT	
	FLARES, HORN	
CANNED FOOD	GROUND TACKLE	GASOLINE
	FENDERS, DOCK LINES	
	TOOLS, SPARE PARTS	
	COOKWARE	



Part No.	Model	Nash No.
100010	Track numbers	203
100011	One 0"-10" scale	204
100012	Stowage locker labels	205
100013	Spar labels	206
100014	Cleat and winch labels	201
100015	Tank labels	208
100016	Control lines	202
100017	Racing flag signals	207
100018	Thru-Hull Labels	209
100019	Plumbing Labels	210
100021	Engine Labels	211
100022	Electrical Labels	212
100023	Instrument Labels	213
100024	Stoppers Labels	214

**HELP**  
**PREVENT**  
**CREW**  
**SNAFU!**

# TILLER EXTENSIONS - Proven Quality & Performance

## TWIST-LOCK TILLER EXTENSIONS

The industry standards are set by **Forespar's**® complete line of hiking sticks with designs and lengths to satisfy every sailor. Our telescoping models offer a choice of three excellent fastening devices: **TFP (Quick-Release)**; **SF (Sta-Fast™)**; and **SL (Speed-Lock)** our new composite universal.

A long time favorite of serious sailors around the world, the **TFP (Quick-Release)** model can be instantly fastened to the tiller by simply depressing the plunger and inserting the detent pin into the special tubular fitting supplied. Again, an easy push on the plunger and the hiking stick is released from the tiller. Stow it or take it home with you. It's fast, simple and secure.



TFP QUICK RELEASE



EXTENDS FROM HERE StaFAST™

**THE ULTIMATE RACER'S CHOICE.**

Part No.	Model No.	Telescopes	Tube Dia.
104016	TFP-S	19" to 32"	3/4" - 5/8"
104017	TFP-M	27" to 48"	3/4" - 5/8"
105110	STX 30"	Fixed	3/4"
105120	STX 36"	Fixed	3/4"
108100	SF-S	19" to 32"	3/4" - 5/8"
108101	SF-M	27" to 48"	3/4" - 5/8"

*New composite cam locks give our time tested twist lock tiller extensions a crisp, positive bite while freely unlocking with a quick turn of the wrist.*

## StaFAST™ END FITTING (SF)

Patented design holds the tiller extension exactly where you leave it. No more sliding down out of reach (not sold separately).



StaFAST™  
STX & SF

5/16" X 2-1/2" bolt

## TILLER CLIPS

Molded of **Marelon**® for exceptional strength.



Part No.	Model No.	Size
941020	MF-671	3/4" Tubing Clip
941021	MF-672	7/8" Tubing Clip
941022	MF-673	1" Tubing Clip
941023	MF-674	1-1/8" Tubing Clip

## TFP QUICK RELEASE



Part No.	Description
104004	TFP Assembly Complete With Socket
104006	TFP Socket (receptacle only)

## TILLER LOCK BOX — TLB

This inexpensive product turns any boat with a ball-grip **Forespar**® tiller extension into a boat with a simple, effective and adjustable tiller lock. Install one into your cockpit coaming and you have it in minutes!

Cut-out dimensions :  
3-3/8"w X 4-3/4"h X 1-1/2"d.

Part No.	Model No.
100000	TLB

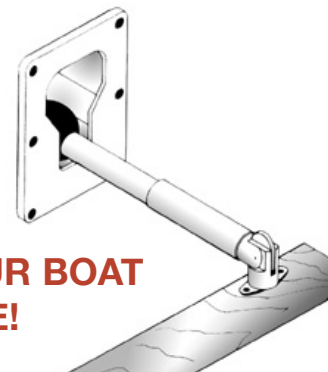

**LOCKS YOUR BOAT ON COURSE!**

# TILLER EXTENSIONS - Proven Quality & Performance

## THE BALL END & GOLF GRIP SWIVEL STICK

Forespar's economical fixed length tiller extension is now a better value. Featuring our removeable Speed Lock (SL) rubber universal end fitting mounted on rugged 5/8" dia. black anodized aluminum tubing with rubber Ball End or Golf Grip style handle. For the small boat (up to 22' maximum) sailor. Available in four of the most popular lengths: 18", 24", 30" & 36".

Part No.	Model No.	Length
102000	SW-18	18 in.
102001	SW-24	24 in.
102002	SW-30	30 in.
102003	SW-36	36 in.
102117	Replacement Speedlock Universal	
102119	Curved Base	
102120	Speedlock Base	

Tube Diameters 5/8"  
(Uses Tiller Clip Part # 941020)



Part No.	Model No.	Length
102008	SWG-18	18 in.
102004	SWG-24	24 in.
102005	SWG-30	30 in.
102006	SWG-36	36 in.
102117	Replacement Speedlock Universal	
102119	Curved Base	
102120	Speedlock Base	

Tube Diameters 5/8"

## SPEED-LOCK UNIVERSAL END (SL)

Forespar® has taken "universal" tiller end fittings to the next level. Our unique "Speed-Lock" end allows for a full 360° of rotation (twist) without binding or failure. It is quickly and easily removed from the tiller by simply depressing the "button" in the base plate and sliding the end out. The base plate is a polymer material for maximum longevity and the universal can be easily unscrewed from the tiller handle and replaced with simple hand tools, if replacement ever becomes necessary

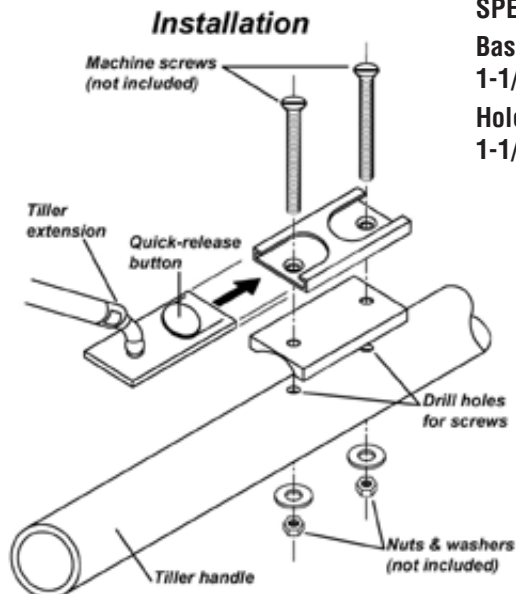

### SPEED-LOCK (SL)

Base dimensions  
1-1/4" x 2"  
Hole Spacing  
1-1/4" Centers



TILLER EXTENSION PARTS KIT  
INCLUDING 7/8" DIAMETER ADAPTOR  
P/N 102220

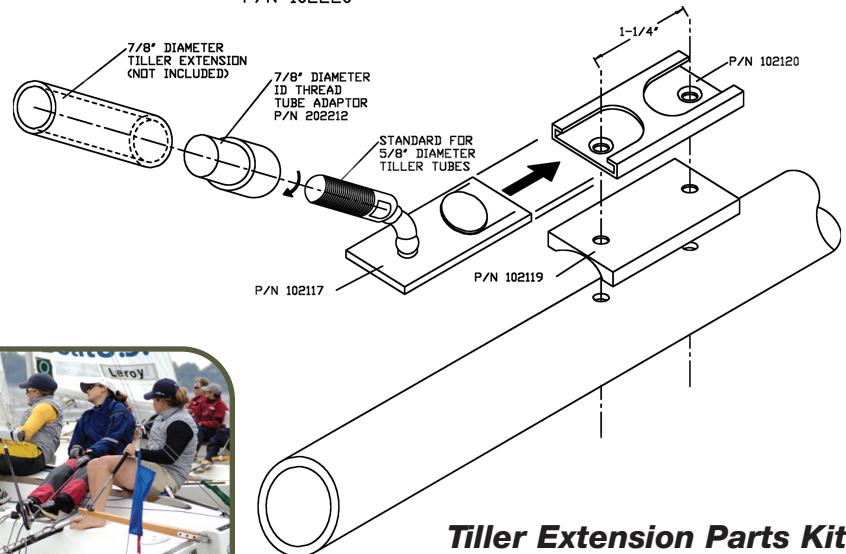

### Tiller Extension Parts Kit

Part No.  
102220

# TILLER EXTENSIONS - Proven Quality & Performance

## “BIG STICKS” CARBON FIBER TILLER EXTENSIONS

- Light, Stiff, Rugged
- Precise Helm Control



Our rugged, light weight tiller extensions are built to stand the test of time on any go fast dinghy or keel boat. They are simple yet elegant. Nothing to go wrong. 7/8” diameter shaft for a solid grip for either men or women. NO Frills, just an extension! Black only.

Part No.	Model No.	Length	
102214	Big Stick Carbon	30”	All straight tubes so that they can be modified by each sailor to tailor fit his/her boat. Simply cut the tube to length on the outboard end. All come with our proven “speed lock” design (see page 27) for quick mount/dismount and easy replacement if necessary. The extensions are shipped loose for custom lengths to suit your class requirements.
102217	Big Stick Carbon	48”	
102216	Big Stick Carbon	72”	

## “GIANT STICKS” CARBON FIBER TILLER EXTENSIONS

- Speed-Lock or StaFAST **NEW**
- Texture Finished for Positive Grip

“The Forespar **Big Stick** is incredibly light and stiff, it provides a great feel in light air and does not flex in the breeze”.

The Big Stick’s big brother, the Giant Stick offers all the features of the Big Stick with a larger diameter tube for a more comfortable and positive feel. 1-1/4” diameter shaft for a solid grip for either men or women. Black only.



**SALLY BARKOW**  
Yngling World Champion  
ISAF Match Race World Champion  
2005 Rolex Sailor of the Year

Part No.	Model No.	Length	Part No.	Model No.	Length
102221	Giant Stick, Speed-Lock	30”	102225	Giant Stick, StaFAST	30”
102222	Giant Stick, Speed-Lock	48”	102226	Giant Stick, StaFAST	48”
102223	Giant Stick, Speed-Lock	72”	102227	Giant Stick, StaFAST	72”

## OCEANRACER™

- Comfortable Grip
- Infinite Lock Positions
- Stainless Steel TFP Universal Joint
- White Powder Coated Anodized Aluminum or Carbon Fiber



The Forespar® OceanRacer™ has been the choice of offshore and inshore racing helmsmen for years. Major world events see the OceanRacer™ on top boats from every port. This year, these extensions have been optimized with the addition of a sturdy remote operating trigger and optional StaFAST™ connection.



Constructed of white powder coated anodized aluminum with a stainless steel attachment fitting, this tiller extension is built to withstand the rigors of offshore competition. The OceanRacer™ is unmatched for comfort and control.

Part No.	Model No.	Telescopes
106025	OR-2 (Aluminum w/ TFP Quick Release)	31" to 41"
106225	OR-2-SF (Aluminum w/ StaFAST option)	31" to 41"
106400	OR-2 (Carbon Fiber w/ TFP Quick Release)	31" to 41"

Tube Diameter 1-1/4”

# MARELON® WINCH, TUBING CLIPS & AWNING POLES

## MARELON® WINCH

Molded of **Marelon®** for exceptional strength, this lightweight winch will easily handle up to 200 square feet of sail. This little winch is ideal for use on the modern trailer-sailor or the small racer. On larger boats it is great for out-hauls and other control lines with relatively low loads. Weighing in at less than one pound you will find many uses for this tough little winch. Use four 1/4" fasteners (not included).

- PRODUCT OF ULTRA LIGHT COMPOSITE TECHNOLOGY
- FOR UP TO 200 SQ. FT. OF SAIL
- ONLY WEIGHS .86 lbs.
- ALL **MARELON®** CONSTRUCTION
- NO CORROSION
- ACCEPTS STANDARD STAR DRIVE WINCH HANDLE
- 8:1 POWER RATIO WHEN USED WITH A 10" HANDLE
- 6:1 POWER RATIO WHEN USED WITH AN 8" HANDLE



**Ideal Halyard & Sheet Winch**

Part No.	Description	Model No.
960003	Marelon® Winch	MW-6

### DIMENSIONS

Height: 3-3/8", Base diameter: 3-5/8"  
 Top diameter: 3-1/4", Drum diameter: 2-7/16"  
 Four 1/4" fastener holes in 1-7/8" square pattern

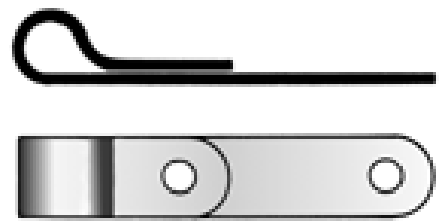

## TERMINAL EYE STRAP

Electropolished 16 ga 316 Stainless Steel Terminal Eye Strap measures 3/8" X 2" with two mounting holes for #8 screws or 1/8" dia. pop-rivets.

Part No	Model No.
301008	TES-1

## TUBING CLIPS

Molded of **Marelon®** for exceptional strength.

**Great For Storing**

- Boat Hooks
- Fishing Poles
- Paddles



Part No.	Model No.	Size
941020	MF-671	3/4" Tubing Clip
941021	MF-672	7/8" Tubing Clip
941022	MF-673	1" Tubing Clip
941023	MF-674	1-1/8" Tubing Clip

## TELESCOPING AWNING POLES

Ideal for boat awnings, **Forespar®** Telescoping Awning Poles are available in four length ranges to accommodate all boat sizes. Featuring our renown internal twist lock mechanism, the poles feature "eye" type end fittings. For larger boats we offer a special Heavy Duty option. Standard size poles have 7/8" and 1" diameter tubing. Heavy Duty poles are 1" and 1-1/8" in diameter.



Part No.	Model No.	Telescopes
503000	TAP 3-6	45" to 71"
504000	TAP 4-8	57" to 96"
505000	TAP 5-10	69" to 120"
506000	TAP 6-12	81" to 144"
505100	TAP 5-10 HD	69" to 120"
506100	TAP 6-12 HD	81" to 144"

# NOVA DAVIT™ & NOVA LIFT™

## NOVA DAVIT™

The **Nova Davit™** system represents the "State of the Art" for styling and function. Versatile mounting designs assure a perfect fit with an offshore strength standard. Like all Nova products, a very high standard of finish will make the right statement about your boat. The neat folding feature stows the davit system flush with your boat's stern. The maximum safe working load is 350 lbs. per pair (175 lbs. per arm).

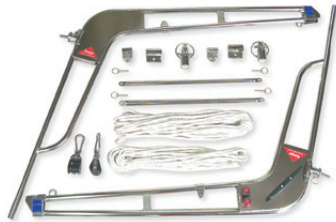

**Light Weight, Strong, all 304 Stainless Steel Davits, with New Attractive Lines.**

**Nova Davit™** Conveniently folds inwards to maintain boat slip length or remove them completely for stowage or racing.

**350 lbs. Safe Working Load per Pair**

Part No.	Model No.
153302	<b>Nova Davit™</b>
153447	<b>Optional 1-1/4 Rail Mount Kit</b>

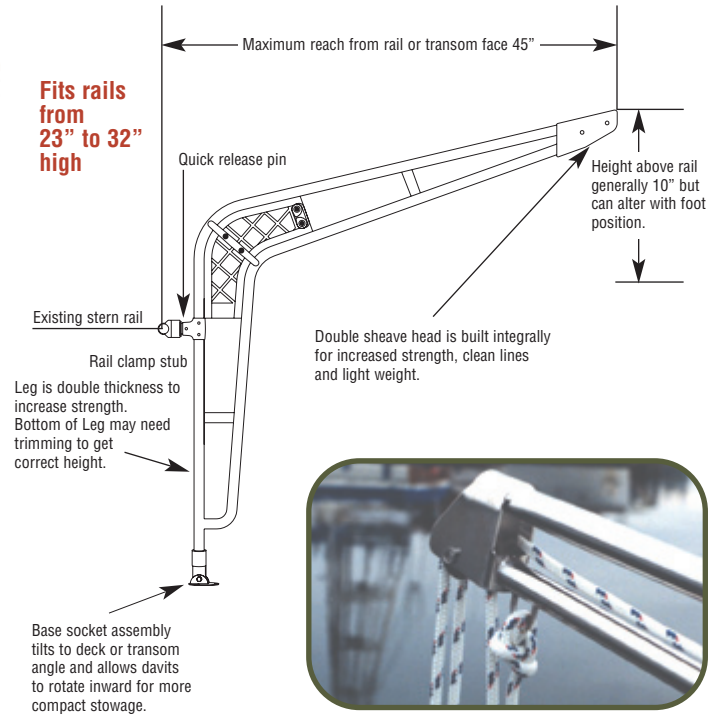
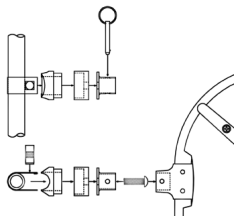

## NOVA LIFT™

Forespar's Nova products combine elegant styling with superb strength and function. The Patented Nova Lifts use internally led purchase to keep the lifting arm centered over the load. Other brands swing left and right without control. Another valuable feature is the internal lead to your cockpit winch where you have loads of lifting power to make the job easy! **No external block & tackle.**

**Nova Lift™** comes with a stainless steel lower mounting tube that will accommodate 30" height rails. Vessels with rails higher than 30" will require the use of a deck pad (not included) to raise the installation to the proper height.

The **Nova Lift™** with winch is ideal for trawlers and motor yachts where sailboat winches are not available.

Part No.	Description
153311	<b>Nova Lift™</b>
153312	<b>Nova Lift™ With Winch</b>
153308	Outboard Motor Sling
153387	1-1/4" Rail Adaptor
153303	Plastic Outboard Motor Mount - 1" Rail
153318	2-5" Optional Stand Off Bracket

### Stand Off Bracket

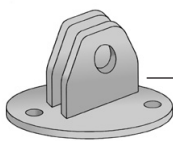

Foot Base  
Diameter = 3"  
Max. angle = 60°  
3 x 1/4" holes  
Base Swivels

**220 lbs. Maximum Load**

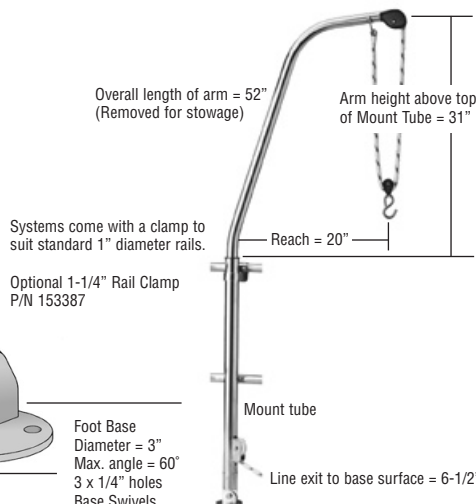

**Nova Lift™**



**Nova Lift™ With Winch**



# MOTOR MATE™ & CARGO MATE™

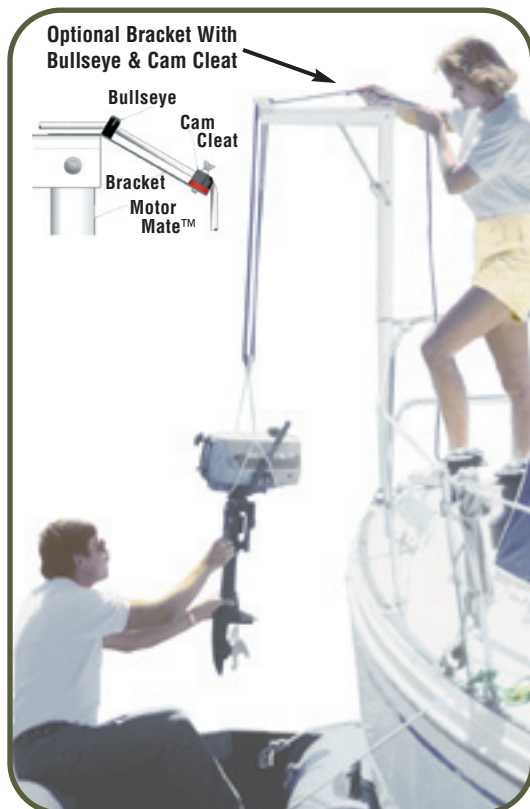

## MOTOR MATE™

Features heavy duty anodized aluminum, powder coated white for added corrosion resistance. The unit stores in its own 31" X 6" bag. Comes with tackle and will lift anything from the dinghy to the cockpit (or vice-versa) up to 100 lbs. Great for the dinghy motor, but also good for SCUBA tanks, ice, duffel bags, groceries, etc.

The **Motor Mate™** uses a **Railfast®** mounted ring on the rail and a "toe" on the cockpit coaming directly under the rail.

- **Light-Weight, Portable, Compact**
- **Ideal for Lifting Outboard Motors, Sea Bags, SCUBA Gear**
- **Lifting Capacity: 100 lbs. (the weight, approximately, of a 15 hp. outboard)**
- **Works Great for Both Power Boats & Sailboats**

**Boom length: 20"**

**Assembled height: 54"**

**Weight: 12 lbs.**

Part No.	Description
153100	Motor Mate™
153104	Base Mount *
153105	Rail Mount *
153130	Cam Cleat Bracket
153109	Vinyl Bag *

\*Included with MOTOR MATE™

## CARGO MATE™

This heavy duty white powder coated aluminum heavy lifter mounts and dismounts with ease. **CargoMate™** stows neatly in a quality bag, and complete tackle is included. Winch drum capacity provides for 13 vertical feet of lift.

With greater lift capacity, the unit should be thru-deck mounted on sailboats and coaming or transom/swim step mounted on power boats. Deck flange and universal base mount provided as standard. 33" column extensions available.

- **The Big Brother to Motor Mate™**
- **Lifting capacity: 250 lbs.**
- **Integral ratchet type winch provides 15 to 1 lift ratio.**
- **For both Power & Sail.**

**Boom length: 34"**

**Assembled height: 54"+**

**Weight: 32 lbs.**

Part No.	Description
153200	Cargo Mate™
153207	33" Extension Tube
153209	Storage Bag*
153230	Deck Mounting Flange*
153233	Power Boat Mounting Ring

\*Included with CARGO MATE™



## RAILFAST® HARDWARE - ATTACH ACCESSORIES TO YOUR BOAT'S SIDE RAILS SO YOU DON'T TAKE UP VALUABLE DECK SPACE!

This great family of truly unique attachment mounts allows you to attach a wide variety of accessories to your round rails on either a sailboat or powerboat. Fish cleaning boards, stoves, flag poles, GPS receivers, fenders, solar panels, your imagination is the only limit to how you can use these products. A boat railing is an excellent place to attach brackets for holding a variety of safety and boating gear, but until now there has been no easy means of making a secure installation.

Now, there's a solution.

The patented **Railfast®** mounting system offers an attractive, yet functional method for mounting gear to a boat railing.

This exploded diagram shows the components and demonstrates the ingenious simplicity of the system. It installs in minutes on any 7/8", 1" or 1-1/4" rail and requires no drilling.

All **Railfast®** system parts are corrosion-proof nylon or stainless steel. An assembly tool and all necessary hardware included.

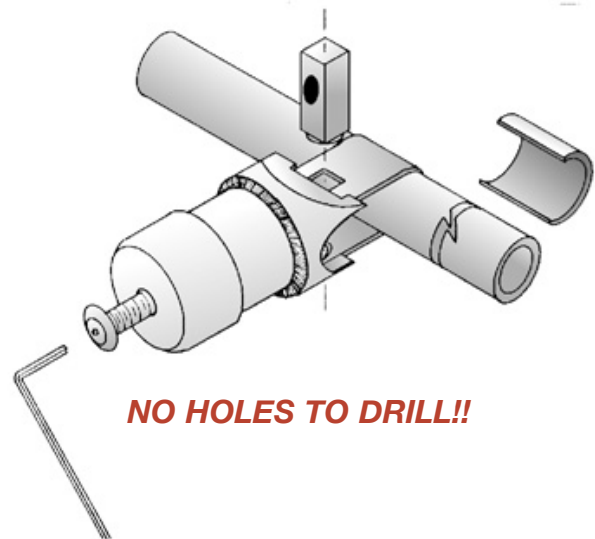

**NO HOLES TO DRILL!!**

**SEE REPLACEMENT PARTS PAGE**

### DO IT YOURSELF!

The number of uses for the **Railfast®** mount is as unlimited as your own imagination!

Assemblies are available that make it easy for you to create your own device to mount almost anything to your railing.

#### MOUNTING BOSS ONLY — 300

The **Railfast®** mounting boss consists of the rail clamp assembly and a cover piece with a flat surface, all secured by a single bolt. Mount fender baskets, running lights, solar panels, barbecues, etc.

**"NEW"  
NOW AVAILABLE  
FOR 1" OR  
1-1/4" RAILINGS**

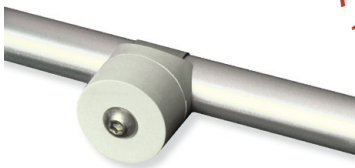

Part No.	Model No.
156011	300-1" Rail
156031	300-1-1/4" Rail

#### MOUNTING FLANGE ONLY — 350

**Railfast®** mounting flange-350 provides a flat, 4-hole mounting surface that can be adapted to a variety of uses. Mount cutting tables, outboard brackets etc. The 350 is also used with the Mini-Galley bracket.



Part No.	Model No.
156012	350-1" Rail
156032	350-1-1/4" Rail

#### FLAG POLE SOCKET 324-FPH

**Railfast®** assembly and flag pole holder make installing flag poles a breeze. The holder can mount at any angle on a horizontal bow or stern rail and will accommodate flag poles with 1" base diameters. A set screw holds flag pole in place.

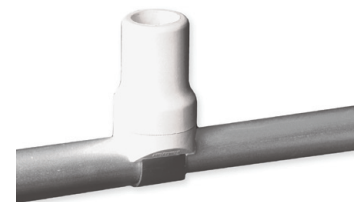

Part No.	Model No.
156006	324-FPH-1" Rail
156026	324-FPH-1-1/4" Rail

## ANTENNA MOUNTS

**Railfast®** offers an ingenious solution to a common problem on boats—where to install antennas without using valuable deck space.

**Railfast®** antenna mounts attach quickly to 7/8", 1" or 1-1/4" railings, horizontally, vertically, or at any angle, providing a professional and secure mounting for standard VHF, CB, and Loran antennas up to 8' in length. A special internal feed-through channel accommodates Loran cable that is routed directly out the bottom of the coupler.

### NYLON ANTENNA MOUNT — 311-N

This version of the nylon **Railfast®** is made without the laydown handle, but is secured to the rail using an allen key which is provided. This mount is ideal for permanent fixed installation of antennas.



Part No.	Model No.
156009	311-N-1" Rail
156029	311-N-1-1/4" Rail

### NYLON ANTENNA MOUNT & HANDLE — 311-NLH

This nylon **Railfast®** is molded with a fiberglass additive, giving it superior strength. The laydown handle makes it easy to raise and lower antennas for passing under bridges and for easy storage or trailering.

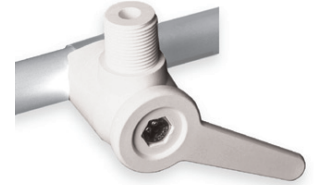

Part No.	Model No.
156008	311-NLH-1" Rail
156028	311-NLH-1-1/4" Rail

## UTILITY HOLDER 300-R

The **Railfast®** ring mounting bracket has a variety of safety equipment uses. A pair of these stainless steel brackets can mount on any 7/8", 1" or 1-1/4" horizontal rail to hold a life ring, or a single bracket can be used to hold line or various other accessories.



Part No.	Model No.
156000	300-R-1" Rail
156020	300-R-1-1/4" Rail



**"NEW"  
NOW AVAILABLE  
FOR 1" OR  
1-1/4" RAILINGS**

## HORSESHOE BUOY HOLDER — 300-H

The **Railfast®** horseshoe mounting bracket is a must for any sailboat. The electro-polished stainless steel bracket is bent precisely so it will hold a standard horseshoe ring securely without the need of a retaining strap, speeding deployment in case of emergency.



Part No.	Model No.
156001	300-H-1" Rail
156021	300-H-1-1/4" Rail

## OVERBOARD POLE HOLDER — 300-M

The **Railfast®** overboard pole holder holds the base of the pole. Easily mounted to the stern rail, close to the horseshoe bracket, it helps provide a complete safety system—with all man-overboard items located in close proximity for speedy deployment when time is of the essence. This unit is made of stainless steel and corrosion proof nylon, and comes with all mounting hardware.



Part No.	Model No.
156003	300-M-1" Rail
156023	300-M-1-1/4" Rail

# MINI-GALLEY® 2000

## MINI-GALLEY® 2000

The **Mini-Galley® 2000** is a compact, versatile, fully gimballed marine stove. This modern, attractive unit includes a low profile mounting bracket which allows the entire stove to be easily detached and stowed when not in use. It features an all stainless steel gimballed "basket" with springs that secure the cooking pot. The **Mini-Galley® 2000** allows cooking under adverse weather conditions in the cockpit or below. The burner can be turned off and on instantly with no preheating or priming necessary. A disposable propane cartridge gives up to 8 hours of hot, clean heat. A simple valve permits any flame intensity. Designed to accept U.S. Department of Transportation approved self-sealing propane bottles. This handy compact stove is ideal for smallcruisers and racers where space is at a premium. On larger yachts, the **Mini-Galley® 2000** is a quick, simple alternative for heavyweather cooking, late night watches or quick hot drinks while underway. It is ideal for any yacht sail, power, racer or cruiser.

### SPECIAL FEATURES:

- EASY TO RELOAD SELF-SEALING FUEL CANISTER \*
- DOUBLE GIMBALING
- STAINLESS STEEL CONSTRUCTION
- INSTANT HOT HEAT
- COMPACT-STOWS EASILY
- ACCEPTS U.S. DEPT. OF TRANSPORTATION APPROVED PROPANE BOTTLES
- PROPANE BOTTLES AVAILABLE WORLDWIDE \*
- 1000-5000 BTU

### SET INCLUDES:

- 1 QT. STAINLESS STEEL COOKING POT
- STAINLESS STEEL MINI FRYING PAN

Part No.	Model No.
150002	MG-2000 <b>MINI-GALLEY® 2000</b>
150001	Optional S/S Tea Pot
150003	Optional Aluminum 6 Cup Percolator
156012	Optional 350 Mounting Flange (See Page 32)
150007	Mounting Bracket Only (Options Sold Separately)

### Optional 6 Cup Percolator

### Optional Tea Pot



Pot & Pan Included



### DIMENSIONS

Diameter: 8"  
Height: 7" (Without fuel canister)  
Weight: 1.5 lbs. (Including mounting bracket)

\* **Forespar®** does not sell the D.O.T. approved propane canisters. They are available from your marine hardware dealer, camping supplies or major department stores in the U.S. and Canada. For European or other cartridges sold outside of the United States, an adapter may be needed for the various threaded canister tops sold outside of North America. These adapters should be secured prior to any long distance voyages outside the U.S. and may vary from country to country. **Forespar®** has designed this unit for use with U.S./ D.O.T. propane cartridges and cannot be responsible for their availability outside the U.S.

# ALUMINUM OR COMPOSITE RADAR SPAR KITS



- Choice of fixed platform or platform that articulates either mechanically or electrically
- Choice of aluminum pole with aluminum platform or carbon pole with composite platform
- Electric motor is Mil. Spec. marinized alignment mechanism
- Choice of deck, transom or thru-deck mounting
  - Provisions for optional antenna arm(s)
- Versatile installation kit
- Two sizes of platforms for 16nm and 24nm radomes
  - Carbon has a 30% weight saving advantage 10 – 12 ft above the waterline
  - Poles come 12 ft long to be cut to custom length as needed
  - Painted Awlgrip Matterhorn White unless otherwise specified

## ALUMINUM RADAR KITS

### FIXED PLATFORM

Part No.	Model *	ALUMINUM	Size
152204	15" Stern Rail Mount		24nm range radomes
152205	15" Thru-Deck Mount		24nm range radomes
152206	12" Stern Mount		16nm range radomes
152207	12" Thru-Deck Mount		16nm range radomes

## CARBON FIBER RADAR KITS

### FIXED PLATFORM

Part No.	Model *	CARBON FIBER	Size
800960	15" Stern Rail Mount		24 nm range radomes
800965	15" Thru-Deck Mount		24 nm range radomes
800950	12" Stern Rail Mount		16 nm range radomes
800955	12" Thru-Deck Mount		16 nm range radomes

## MECHANICAL HAND CRANK ALUMINUM RADAR KITS

### ARTICULATING PLATFORM

Part No.	Model *	ALUMINUM	Size
152200	15" Stern Rail Mt. Mech.		24nm range radomes
152201	15" Thru-Deck Mt. Mech.		24nm range radomes
152202	12" Stern Rail Mt. Mech.		16nm range radomes
152203	12" Thru-Deck Mt. Mech.		16nm range radomes

## MECHANICAL HAND CRANK CARBON FIBER RADAR KITS

### ARTICULATING PLATFORM

Part No.	Model *	CARBON FIBER	Size
800913	15" Stern Rail Mount		24 nm range radomes
800911	15" Thru-Deck Mount		24 nm range radomes
800912	12" Stern Rail Mount		16 nm range radomes
800910	12" Thru-Deck Mount		16 nm range radomes

## ELECTRIC TILT ALUMINUM RADAR KITS

### ARTICULATING PLATFORM

Part No.	Model *	ALUMINUM	Size
152225	15" Stern Rail Mt. Mech.		24nm range radomes
152227	15" Thru-Deck Mt. Mech.		24nm range radomes
152226	12" Stern Rail Mt. Mech.		16nm range radomes
152228	12" Thru-Deck Mt. Mech.		16nm range radomes

## ELECTRIC TILT CARBON FIBER RADAR KITS

### ARTICULATING PLATFORM

Part No.	Model *	CARBON FIBER	Size
800900	15" Stern Rail Mt. Elec.		24 nm range radomes
800905	15" Thru-Deck Mt. Elec.		24 nm range radomes
800920	12" Stern Rail Mt. Elec.		16 nm range radomes
800925	12" Thru-Deck Mt. Elec.		16 nm range radomes

## CARBON FIBER & ALUMINUM RADAR SPARS

(STANDARD POLE LENGTHS - 12 FT. AND CUSTOMERS SIMPLY CUT TO LENGTH)

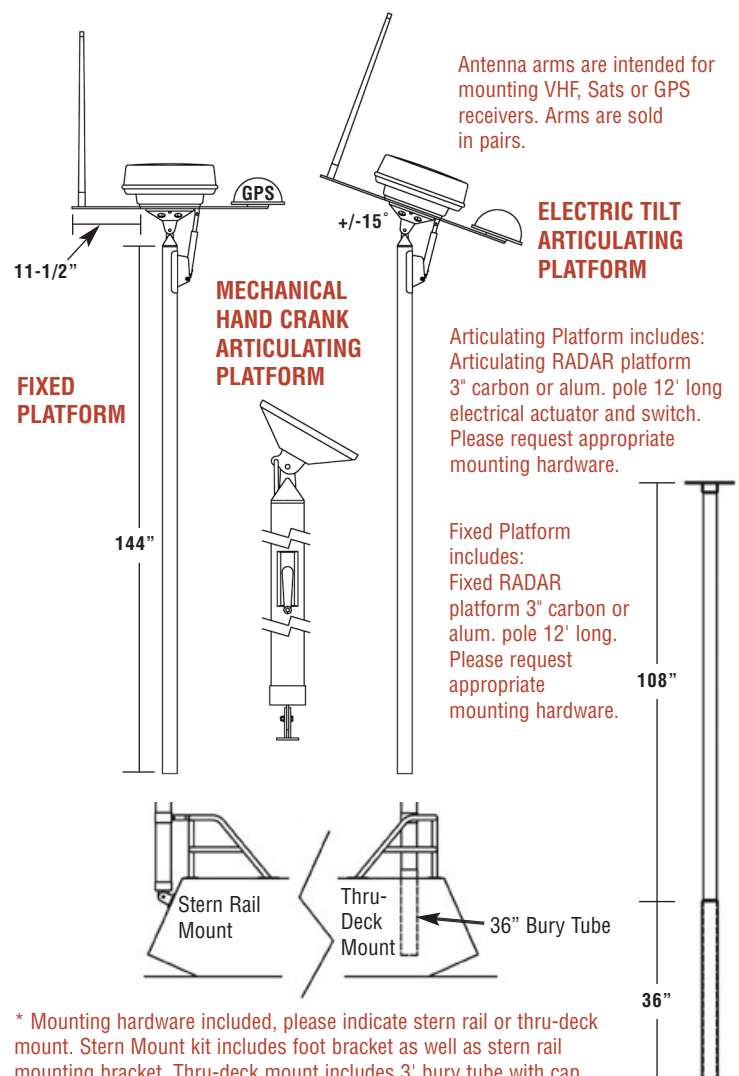

\* Mounting hardware included, please indicate stern rail or thru-deck mount. Stern Mount kit includes foot bracket as well as stern rail mounting bracket. Thru-deck mount includes 3' bury tube with cap and locking rotational pin.

## ANTENNA ARMS

Part No.	Model *	Size
152230	Aluminum Antenna Arms (pair)	12" long each
152240	Aluminum Antenna Arms (pair)	15" long each
800930	Carbon Antenna Arms (pair)	12" long each
800940	Carbon Antenna arms (pair)	15" long each



\* Standard Carbon and aluminum tubing painted Awlgrip Matterhorn White unless otherwise specified.

# LEISURE FURL™ MAINSAIL BOOM FURLING SYSTEM

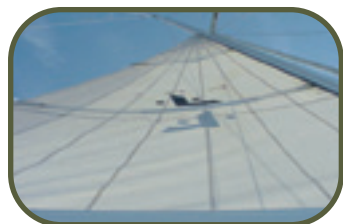

## THE OFFSHORE SYSTEM

**THE SMART CHOICE** - Worldwide recognized leader for in-boom systems for boats 33' - 85'. There are over 4,000 systems in use making passages all over the world's oceans in all sea conditions. With over 15 years of development; the Leisure Furl™ in-boom furling system is a highly efficient, safe and simple method of reefing and controlling the mainsail.



## LEISURE FURL™ FEATURES

- Each boom is custom engineered and fabricated for your boat
- Each boom is elegantly tapered for attractiveness and weight savings
- Easily fitted to an existing mast without the need to unstep your mast
- Aluminum extrusions are spar grade 6005 T5 heat treated alloy for superior strength
- All gooseneck fittings are high-strength 17-4 investment cast stainless steel
- Limited 5-year warranty

## LEISURE FURL™ CONVENIENCE

- Remove Sail Cover & Ties and Stow Away
- Lower and Flake the Sail
- Tie Sail and Replace the Sail Cover

### Conventional Boom

- 15 minutes
- 10 minutes
- 15 minutes

### Leisure Furl™

- 30 seconds
- 90 seconds
- 30 seconds

## LEISURE FURL™ OPTIONS INCLUDE

- Aluminum Construction
- Carbon Fiber Construction
- Hydraulic Drive Option
- Anodized or painted in any Awlgrip® Color



## SAILKOTE

RECOMMENDED  
FOR LUFF TRACK  
AND BOLT ROPE  
APPLICATIONS



### Built-in Sail Cover

Each Leisure Furl™ boom comes standard with a built-in sail cover for convenience and ease of handling. The Sunbrella® sail cover protects the sail from the harmful elements.



### Manual Override

Each offshore system has a built-in manual backup in case of halyard or furling line failure. Winch handle control is easily accomplished at the mast. The internal ratchet allows the system to be locked in place for long passages.



### Load Bearing Points

Leisure Furl's unique design offers 3 separate load bearing points. The mainsail and boom loads are distributed primarily to the mandrel and drive shaft bearing while the mainsheet and vang loads are carried by the gooseneck fitting.

# LEISURE FURL™ MAINSAIL BOOM FURLING SYSTEM

## THE COASTAL SYSTEM

### HEAVY WEATHER IN-BOOM FURLING & REEFING

### FOR SAILBOATS 26'-35' Maximum luff (P)=40' Maximum foot (E)=14'

This powerful boom system incorporates an end boom drive system with a minimum of moving parts which is effective for smaller boat applications. Our Offshore, through the mast, drive system is used on more powerful mainsails on boats from 35 ft – 85 ft.

The aft drive mandrel uses fiber impregnated composite bearings similar to those used in the construction of big boat high load blocks. The forward universal allows complete freedom of rotation under the highest loads.

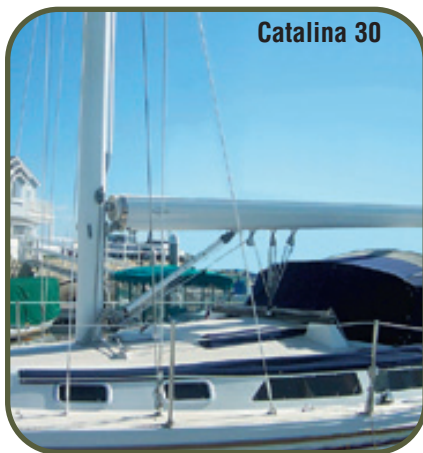

Catalina 30

### Hand Crafted Boom

Each boom is custom made at our plant in Southern California by professional riggers. The boom is tapered for refined styling and weight savings.



Morris 36

### Luff System

Leisure Furl™ uses high modulus PVC luff track.



### Reinforced Entry Area

Each Forespar Leisure Furl has an additional stainless steel frame at the front of the boom. This reinforces the already tough aluminum section.

## WHY SHOULD I CHOOSE LEISURE FURL™?

- **Safety** – With all lines lead aft, Leisure Furl™ gives you the ability to reef and control the main from the safety of the cockpit. Leisure Furl™ eliminates the need for complicated lazy jacks or sending crew members forward in heavy weather.
- **Ease of use** – Hoisting, furling or reefing is a one person operation.
- **Reefing** – A Leisure Furl™ boom allows infinite reefing positions on all points of sail.
- **Appearance** – Leisure Furl™ The sail furls neatly into the boom protecting the sail from harmful ultraviolet rays. Boom is elegantly tapered for attractiveness and weight savings.



Morris 52



Hunter 44



Seguin 52



Ted Hood Portsmouth 48



Stevens 53



## **FORESPAR<sup>®</sup>** **CARBON**



Custom Carbon Boom -  
Nantucket Splinter



## **FORESPAR<sup>®</sup>** **CRUISING SPARS**

Hylas 66 -  
Mast &  
Leisure Furl  
Boom



Schock 40  
Carbon  
Mast



## **FORESPAR<sup>®</sup>** **RACING SPARS**



Courtesy of Richard Spindler

*Forespar<sup>®</sup> builds superior quality aluminum and carbon fiber spar systems for builders of the finest yachts, worldwide.*

*Our sales department establishes the customer relationship, develops the order and serves as the conduit for information during the project.*

*Engineering develops the design data using CAD systems and several proprietary computer programs to optimize the spar system.*

*The manufacturing team then fabricates the spars in conjunction with a multilevel quality control system. The spar systems are finished using Awlgrip marine coatings, then assembled using the high quality components that our customers demand.*

*After passing the final inspection, the spars are packaged to be shipped anywhere in the world.*

*The result of the process is superior reliability and function for the offshore sailor.*





# TABLE PEDESTAL SYSTEMS

## TABLE PEDESTAL SYSTEMS

The **Forespar**® Table Pedestal System features the choice of gas charged, non-gas high/low and fixed length table pedestals and incorporates bases molded from our exclusive light weight and corrosion resistant **Marelon**®. This polymer composite material assures that the table bases will not corrode, blister or crack in the marine environment.

Forespar's table systems feature top quality gas lifting springs and a positive locking device. Columns are marine grade anodized aluminum. Surface bases are available in powder coated "hammer-tone" silver or molded "teak-look" finish. Flush bases are "hammer-tone" silver only.

### SPECS

The bases are 9-3/4" diameter. The standard gas and non-gas high/low systems are 13" collapsed measured from the flange of each base with a 5" bury below the sole. The lower base is epoxied to the tube. Maximum height is 26". The base can be moved up or down upon request however, the overall length of the tubes stays constant. For example if you request a 2" bury, you will have a 16" collapsed height(see diagram). The upper mounting flange is a tapered "slip fit" to the tube. This may also be epoxied for added stability and strength. All tube is sold by the inch and includes any/all tapers required.

Part No.	Model
161001	Gas spring set-silver coated surface bases
161004	Gas spring set-"teak-look" surface bases
161003	Non-gas high/low set-silver coated surface bases
161006	Non-gas high/low set-"teak-look" surface bases
164021	3"(76mm) silver coated surface base only
164009	3"(76mm) "teak-look" surface base only
164011	2-3/8"(60mm) silver coated surface base only
164008	2-3/8"(60mm) "teak-look" surface base only
164034	3"(76mm) plug/cap/cover
164035	2-3/8"(60mm) plug/cap/cover
170001	2-3/8"(60mm) fluted aluminum tube*
170002	3"(76mm) fluted aluminum tube*
170003	2-3/8"(60mm) brown anodized fluted aluminum tube
170004	3"(76mm) brown anodized fluted aluminum tube



## STANDARD DIMENSIONS

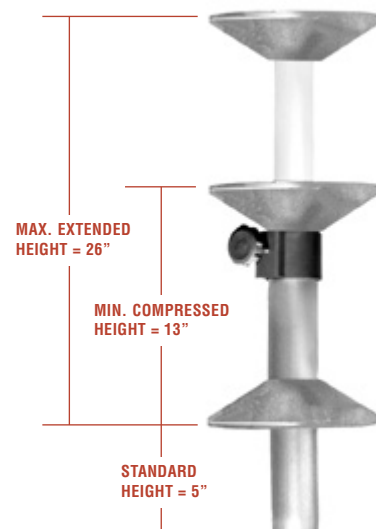

**29" MAXIMUM FIXED LENGTH**

# REPAIR & REPLACEMENT PARTS

## AWNING POLES

For TAP 3-6, TAP 4-8, 6-12, 5-10 HD and 6-12 HD

Part No.	Model No./Description
504003	End Kit

## MAST CARS

AT-125-S/T-125-S

Part No.	Model No./Description
333010	Toggle/Knuckle assembly
331013	Plastic Runners
333000	Shackles

FC-125/FC-125-SP

Part No.	Model No./Description
332003	FC Flange only
332005	Hinge Pin
331013	Plastic Runners

## DECK CHOCKS

Part No.	Model No./Description
332007	DC-2 Spool replacement spool only
300005	DC-TS Post replacement post only

## DECK FILLS

Part No.	Model No./Description
907024	Red Fuel Cap
907025	Blue Water Cap
907026	Black Waste Cap

## SPINNAKER POLES

For EL-150 thru EL-300-EF

Part No.	Model No./Description
408025	Repair Kit

For XP-200 thru XP-450-EF

Part No.	Model No./Description
309080	Repair Kit

For TR-200 thru TR-450-EF

Part No.	Model No./Description
309049	Repair Kit

For TS-300 thru TS-450

Part No.	Model No./Description
309050	Repair Kit

## MAST LIGHTS

ML-1 Part No.	Description
132009	Replacement Lens ring (new)
132035	Bottom Bulb Assy.

ML-2 Part No.	Description
132009	Replacement Lens ring (new)
132025	WN 211 Top Bulb
132035	Bottom Bulb Assy.
132041	Top Lens and Cap Assy.

## RAILFAST®

Part No.	Description
002066	Screw 3/8"
156050	Base-Fiberglass
156052	Bracket strap
156053	Pin-square
156055	Bracket shim-7/8"
156056	Allen wrench
156058	Boss cover

## WHISKER POLES

ADJ 4-8

Part No.	Model No./Description
300026	Repair Kit
400006	Lock Repair Kit
404010	7/8" inner tube w/ lock
504002	1" outer tube

ADJ 6-12

Part No.	Model No./Description
300027	Repair Kit
400008	Lock Repair Kit
406015	1 1/8" inner tube w/ lock
406001	1 1/4" outer tube

HD 6-12 DL

Part No.	Model No./Description
304015	UEF-3 special inboard end
304018	UEF-5 outboard end
400009	Lock Repair Kit
406211	1 3/4" inner tube w/ lock
406202	1 7/8" outer tube

ADJ 7-17 DL

Part No.	Model No./Description
304018	UEF-5 outboard end
304057	UEF-3 inboard end
400010	Lock Repair Kit
407007	1 3/4" inner tube w/ lock
407008	1 7/8" middle tube w/ lock
406210	2" outer tube

## CARGO MATE™

Part No.	Description
153230	Deck Flange
153204	Base Mount
153207	33" extension
153232	Plug for Deck Mount
153233	Transom Ring Mount (Power)
153209	Storage Bag

## MOTOR MATE™

Part No.	Description
153104	Base Mount
153105	Rail Mount
153107	Bottom Tube only
153109	Vinyl Bag

## THRU-HULL PARTS

Part No.	Description
907007	CF 249 1/2" nut only
907008	CF 249 3/4" nut only
907009	CF 249 1" nut only
907010	CF 249 1 1/4" nut only
907011	CF 249 1 1/2" nut only
907012	CF 249 2" nut only
403125	Small Mold Plug (OEM only)
403135	Large Mold Plug (OEM only)

## MARELON® PLUMBING SYSTEM PARTS

Parts No.	Description
930072	Cap/Plug/Bung
930073	Cap/Plug/Bung
930074	Cap/Plug/Bung

## Line Control™ Whisker Poles

Replacement Inboard Ends

LC 8-14

Part No.	Model No./Description
408041	EL-200-LC EF

LC 10-18

Part No.	Model No./Description
401035	EL-250-LC EF

LC 12-22

Part No.	Model No./Description
402037	EL-300-LC EF
304038	Ultra Collar

LC 13-24

Part No.	Model No./Description
403104	LCC-1 Collar

LC 15-27

Part No.	Model No./Description
405102	LCC-2 Collar

## TILLER EXTENSIONS

Part No.	Description
104004	TFP - Assembly Complete w/ Socket
104006	TFP - Socket (Receptacle) Only

## ULTRA END FITTINGS

Part No.	Description
304029	UXP - Repair Kit
304030	UTR 200 & 250- Repair Kit
304031	UTR 300 & 350- Repair Kit

## SAFETY GEAR

HLD-1 Launcher

Part No.	Model No./Description
080056	Shock Cord
080057	Shock Cord
204102	Stainless Steel Stand

SP-2 Package

Part No.	Model No./Description
204100	HLD-1 Launcher
204002	CH-5-Y Horseshoe Buoy
205102	WL-1 Water Light
205103	Drogue
205104	Whistle
205105	Dye Marker

OP-120, OPST-120 Overboard Poles

Part No.	Model No./Description
202026	Flag
202132	Stainless Steel Clip
202020	Replacement Top Half With Flag

Forespar®  
uses  
AWLGRIP®  
Marine Coatings  
**AWLGRIP®**

# Forespar® Products, Policies and Contacts

## QUALITY COMPONENTS

Whatever you order, you'll receive more for your money from **Forespar®**. For example, we only use Spectron 12® composite line on our bridles and heavy duty vinyl on our lanyard wire, not the thin coated type for sailmakers. Our castings are prime type 356 aluminum alloy, heat treated to T-6 condition for strength and a higher coefficient of elongation. This means a reduction in brittleness without reducing the heat treated strength.

## SUPERIOR ANODIZING

The clear anodizing used on our tubing meets military specifications, which means approximately three times the coating thickness of "commercial" grade anodizing. Our end fittings, where corrosion resistance is particularly important, are carefully machined, extensively deburred and then finished with a high quality, hard coat finish of 2 mil. minimum thickness anodizing. Our fittings are not dyed painted or stained to cover up lesser quality, and we invite you to compare **Forespar®** fittings with those of any other manufacturer.

## ORDERING OPTIONS

**IMPORTANT** - There are three distinct ways to order our spinnaker poles, reaching struts and jib booms.

- 1. CUSTOMIZED:** Poles may be ordered to the specific length required for your boat. Simply specify our Model No. and the exact overall length required.
- 2. "KIT" FORM:** Everything for a complete pole job is included in our "Kit" packages. The tubing is supplied in the maximum length recommended for the particular diameter ordered. One end fitting is left unfastened so that the tubing can be cut to length, before final customizing. By keeping an inventory of kit poles, you can quickly and easily customize them to whatever length your customer requires. This eliminates "single item" freight costs and keeps your customer happy with fast immediate service.
- 3. FITTINGS AND TUBING:** If you have the know how, and the simple tools necessary, you can order the component parts and save money by doing the assembly yourself. Simply specify the model numbers of the end fittings and tubing sizes required.

## PACKING

Every boom or strut is individually packed in its own shipping container for maximum protection and a "new" look when it arrives at its destination. Multi-packed items are protected by individual polyethylene bags.

## RETURNED MERCHANDISE

No returns will be accepted without prior agreement from **Forespar®** including instructions on method of shipment and return authorization number. Customized merchandise is not returnable. Any unused, undamaged merchandise accepted for return will be subject to a 20% return and handling charge.

## REPAIRS

Repairs necessary due to accident, misuse or normal wear and tear, will be made at customer's request. Charges for such repairs will include published price of replacement parts and reasonable labor costs. All merchandise being returned for repair must be shipped prepaid and include return address and repair instructions.

**A Return Authorization Number from our Customer Service department is required.**

**Forespar®** is a registered trademark of Forespar Products Corporation.

Product pricing, design and specifications are subject to change without notice.

## WEBSITE

[www.forespar.com](http://www.forespar.com)

## EMAIL

Customer Service  
[sales@forespar.com](mailto:sales@forespar.com)

## Spar Division

[sparman@forespar.com](mailto:sparman@forespar.com)  
[alan@yachtprojectsetc.com](mailto:alan@yachtprojectsetc.com)

## Spar Engineering

[sparman@forespar.com](mailto:sparman@forespar.com)  
[schetelat@forespar.com](mailto:schetelat@forespar.com)  
[peterh@forespar.com](mailto:peterh@forespar.com)



Forespar Corporate Headquarters

Catalog Printed in Hong Kong

Catalog Price  
\$2.00

Catalog Design by  
Mink Graphic Design (714) 434-1405



# **FORESPAR<sup>®</sup>**

**MARINE PRODUCTS THAT PERFORM**



## **FORESPAR PRODUCTS CORPORATION**

22322 Gilberto, Rancho Santa Margarita, CA USA 92688

Ph: 949.858.8820 • Fx: 949.858.0505

Customer Service Email: [sales@forespar.com](mailto:sales@forespar.com)

Spar Division Email: [sparman@forespar.com](mailto:sparman@forespar.com)

[WWW.FORESPAR.COM](http://WWW.FORESPAR.COM)



# **FORESPAR<sup>®</sup>**

**SAILBOAT HARDWARE**

