



FORESPAR[®]
LEISURE FURL[™]

***OFFSHORE
IN-BOOM FURLING SYSTEM***

**UPDATED
VERSION**

May 19, 2011

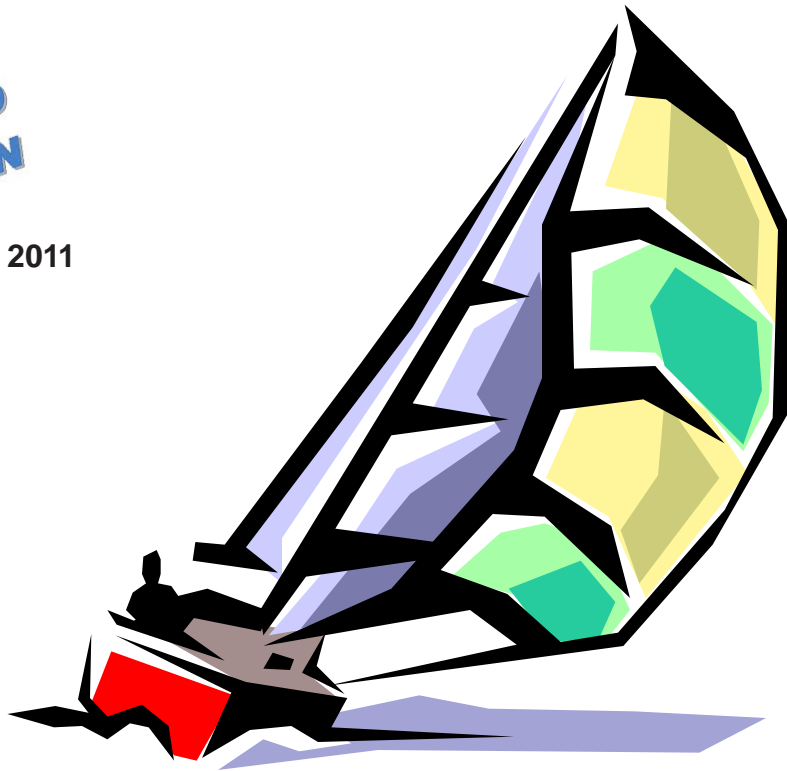

Owner's Manual

Maintenance and Operation

THE INFORMATION CONTAINED IN THIS MANUAL IS TO BE USED AS A GUIDE FOR THE SAFE OPERATION OF THE LEISURE FURL SYSTEM. WE RECOMMEND YOU KEEP THIS MANUAL ON BOARD FOR REFERENCE.

Index

Disclaimer	3
Component list	4
Sail Fitting	5
Setting the boom height	6
Hoisting the sail	7
Furling the sail	8
Sail control	8-10
Sail adjustments	11
Sail feeder alignment	12
Operating tips	13
Trouble shooting	14
Maintenance schedule	15
Manually setting the boom height	16
Your questions	17
Glossary of terms	18
Agents world wide	19
IMPORTANT INFORMATION	20, 21

FORESPAR PRODUCTS CORP.

22322 GILBERTO
RANCHO SANTA MARGARITA, CA 92688
PHONE 949-858-8820 FAX 949-858-0505
EMAIL alanm@forespars.com

IMPORTANT

Read this manual from cover to cover before attempting to use the Leisure furl. It contains important operating and sail fitting instructions. The “Your Questions” section contains important tips and troubleshooting advice.

Follow the instructions in this manual. We accept no responsibility if you fail to do so.

If you are uncertain of any points please contact an authorized distributor listed on the back cover.

We have made every effort to explain the operating and sail fitting procedures as clearly and completely as possible. Nonetheless, it is not possible to anticipate, or address every conceivable problem that might arise under actual sailing conditions. Hence, we cannot accept responsibility for errors or omissions in this manual.

This manual is intended to provide general guidance to owners of a Leisure furl system. For specific guidance and technical support, contact the person who sold you the Leisure furl system, or an authorized distributor listed on the back cover.

Learn how to use the Leisure furl system before taking your boat out on open waters.

The operator is expected to have prior sailing experience, including knowledge of generally recognized safe sailing procedures. The operator should also have an understanding of such basic sailing techniques as hoisting and reefing a sail. The instructions in this manual should be read in conjunction with such techniques and safe sailing procedures. Such techniques and procedures shall be deemed to supplement the instructions in this manual.

Use the Leisure furl at your own risk. We accept no liability for personal injury or property damage resulting from your failure to follow the instructions in this manual or generally recognized safe sailing procedures. As the manufacturer did not install the Leisure furl, we accept no liability for personal injury or property damage resulting from faulty installation.

WARNING — It is possible for the furling mandrel to slide off the aft spigot, if the boom is lowered to the deck, resulting in possible damage to the mast area and universal if raised into position without realignment. Ensure the mandrel is aligned with the spigot before lifting up to the desired height.

Boom vang & topping lifts

In-boom furling systems require both a rigid boom vang and a traditional boom topping lift for safety and ease of sail trimming.

When furling or reefing, the boom should be adjusted to the required 87° angle and held at that angle with the support of the boom vang during the furling process. In heavy weather the boom topping lift should be used to arrest the motion of the boom during furling.

When the boat is moored a boom topping lift will extend the life of your boom vang, no matter what type; spring, pneumatic, hydraulic or electric.

Leisure furl Components list

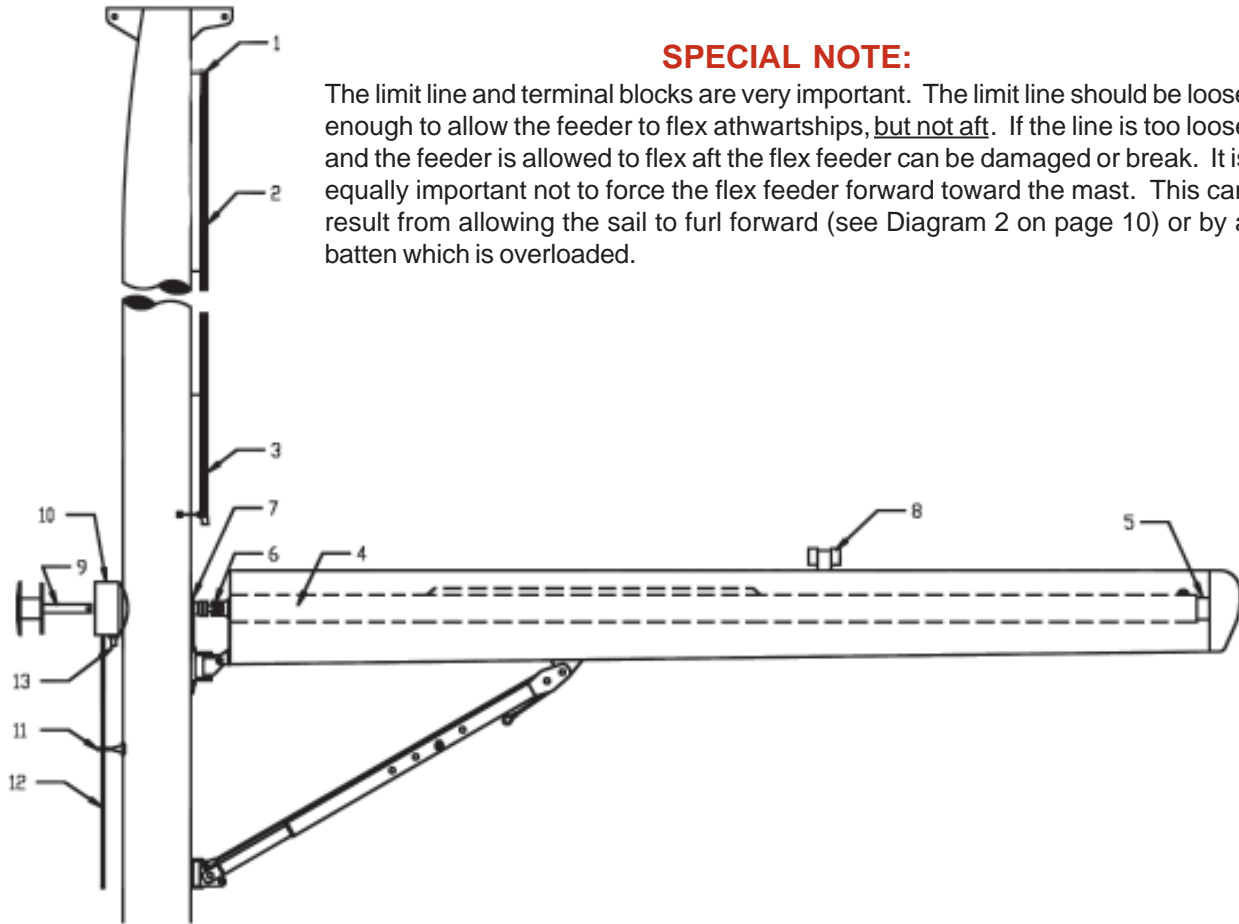

SPECIAL NOTE:

The limit line and terminal blocks are very important. The limit line should be loose enough to allow the feeder to flex athwartships, but not aft. If the line is too loose and the feeder is allowed to flex aft the flex feeder can be damaged or break. It is equally important not to force the flex feeder forward toward the mast. This can result from allowing the sail to furl forward (see Diagram 2 on page 10) or by a batten which is overloaded.

- 1 Luff track cap
- 2 Sail track
- 3 Flex feeder
- 4 Mandrel
- 5 Outer bearing
- 6 Universal
- 7 Inner bearing
- 8 Support bracket
- 9 Spool & Shaft
- 10 Spool cover
- 11 Rope guide
- 12 Furling line
- 13 Ratchet lock

Leisure furl Sail fitting instructions

Initial check

- Ensure the furling mandrel rotates freely. Lubricate as per “maintenance schedule” if necessary.
- Ensure the feeder is correctly aligned with the sail track, see dia 5. Adjust to correct if necessary, see sail feeder alignment.
- If already fitted remove the furling line before fitting the sail

Sail fitting

1. With the sail laid on the port side, lift the foot up to the furling mandrel, then slide the foot boltrope into the track, from either forward or aft.
2. Attach first the tack to the furling mandrel, leaving around 1-1/4” between the tack web and tack ring on the universal, see *adjustment A*, dia 4.
3. Now lash the clew to the outhaul saddle, see *adjustment C*, dia 4. ***Do not pull the foot out tight***, leave fullness in the foot for efficient down wind sailing. The in built sail controls will generate outhaul tension.
4. ***Lash the clew with a minimum of three wraps around the furling mandrel, using a separate lashing, pulling the clew down to within 3/8” of the mandrel.***
5. Using a winch handle inserted into the drive gear, roll the sail onto the port side of the mandrel. (We recommend two persons assist by pulling either the luff or leach, so as to ensure the boltrope remains in the area between the boom edge and the mast, whilst the sail is being furled).
6. In some special cases, hoisting the sail from the deck may be preferred, as the spool and boom height from the deck may inhibit manual fitting. In this instance the furling line will need to be pre-wound on the spool before the sail is attached, and the boom set to the correct angle for furling, see *setting up boom height*, before the sail is hoisted.
7. With the sail rolled fully on the mandrel, fasten one end of the furling line to the spool, by firstly placing five turns around the spool drum in a counterclock wise direction, looking aft, then pass the free end through the hole in the spool. Tie a single knot as close to the end as possible, and push the knot into the counter bore of the spool drum.

The sail fitting is complete, however minor adjustments may need to be made as the lashings stretch. ***A luff lube with a PTFE or similar base should be applied to the luff tape as needed to reduce the friction in the luff foil.***

Leisure furl setting up boom height

See *Hoisting the sail*

To establish the correct operating angle for the boom, once at full hoist, over tension the main halyard. This will give an accurate indication of the tack angle. Pull on the topping lift, cleat this off and substantially mark a position at the rope clutch for future reference. This is the correct boom angle for furling. Release the topper if interfering with the mainsail. It is probable that the topping lift will stretch, so review the height as above or as suggested on page 16 regularly.

Release the load of the main halyard until wrinkles just start to appear at the luff. Engage the main halyard clutch, and mark a position on the main halyard at the entrance of the rope clutch for reference. This position will be normal maximum hoist. With the foot track on the mandrel in its uppermost position, ensure adequate fullness has been allowed for. This should now be a relatively full and powerful down wind sail. Adjust if required see *sail adjustments page 11*.

With the main halyard clutch still engaged, pull on the furling line. This will flatten the foot and tension the luff, as if an outhaul and cunningham had been applied. This becomes an efficient up wind sail. (Note – on larger yachts and in stronger winds it is desirable to use the ratchet lock to avoid creep). When the furling line is released, the mandrel will rotate back to the down wind position.

Setting up the reef points for the sail.

- Snub the main halyard around a winch or T cleat, to take the halyard load once the rope clutch is released.
- Release the main halyard rope clutch, ensuring load on the halyard is maintained.
- Pull in on the furling line, as you ease the main halyard. Apply the desired amount of resistance to the halyard so as to control the amount of “pull back”. See *sail control page 8 and 9*.
- When each batten is approximately 1” from the furling mandrel, engage the main halyard rope clutch, then flatten the sail further by pulling in on the furling line, over tensioning the luff each time. The batten should lie along the mandrel, and the sail should flatten along the foot. The batten in this position avoids fullness creeping into the foot, so where possible reef on any of the batten positions.
- At each of the reef positions mark the main halyard at the clutch position for future height reference.

Leisure furl operating instructions – Hoisting the sail

Apply a substantial coat of the luff lube supplied ensuring that there is an adequate coating at the inside of the boltrope and batten ends. From there on a couple of times a season should suffice.

Pre check before hoisting the sail

- *Guide the sail into the feeder. Attach the main halyard*
- *Check that the boom is at the correct, 87° angle to the mast.*
- *Ensure the ratchet lock is disengaged.*
- *Release the main sheet, and position the yacht head to wind, so as to unload the sail.*

Sail hoisting

1. Load the halyard winch with the main halyard and release the furling line rope clutch.
2. Proceed to hoist the sail, allowing the furling line to pull lightly through the hand. (If windy snub the furling line around a winch or similar to avoid the sail unraveling uncontrollably if the sail should unintentionally fill but still with only light resistance)
3. Hoist the sail fully, or to a reef position.
4. Lock off the furling line rope clutch.
5. Proceed to sail.

Controlling sail shape (luff tension & outhaul)

The in built sail controls allow sail shape to be controlled without the use of a cunningham or outhaul, by simply tensioning the furling line.

To flatten the sail for upwind conditions.

1. Lock off the main halyard rope clutch, then over tension the furling line.

This rotates the furling mandrel and draws fullness out of the foot as with an outhaul, at the same time as tensioning the luff as with a cunningham. Do not adjust the main halyard.

Pre check prior to reefing or furling the sail

- Check that the boom is at the correct, 87° angle to the mast, *see setting up boom height.*
- Release the main sheet, with the yacht on a close reach, so as to unload the sail.
- If reefing while on a reach, ensure the boom is not out more than 45 degrees.

Sail furling

1. Snub the main halyard around a winch or T cleat, to take the halyard load once the rope clutch is released.
2. Release the main halyard rope clutch, ensuring load on the halyard is maintained.
3. Pull in on the furling line, as you ease the main halyard. Apply the desired amount of resistance to the halyard so as to control the amount of “pull back”. *See sail control page 8 and 9.*
4. Once at the desired reef position, engage the main halyard rope clutch, then flatten the sail further by pulling in on the furling line until the foot is completely flattened.
5. Proceed to sail.

Notes

The mandrel locking ratchet has been incorporated into the system so the load can be released from the furling line. It does not have to be used, but when engaged, can be extremely useful in the following circumstances.

- When the sail is to be reefed for a long period of time.
- In the event of deck gear, or furling line failure, a winch handle can be inserted in the faceplate of the spool. With the ratchet engaged it will allow for manual furling without fear of a counter rotation.
- Whilst racing the yacht, when an effective outhaul and cunningham is required, it is necessary in stronger winds to engage the ratchet to avoid the creep that will occur as the furling line pulls into the turns of rope on the spool. Without the ratchet, the furling line will have to be re-tensioned. Due to the load on the locking pin, the system will need to be unloaded prior to the locking ratchet being disengaged. To do so just pull on the furling line.

Pull back

Pull back is a term used to refer to the sail gradually working back along the mandrel as it is furled and is visible as lines on the sail, stretching back from the feeder at an angle to the furling mandrel. A system that is set up and operated correctly will control the amount of pull back, and sail shape. Ideally the sail should always furl neatly, and directly under the feeder. Indications that the sail is pulling back excessively will be highly visible by lines stretching through the sail from the feeder.

If the sail shows these signs of substantial pull back, reduce the resistance on the main halyard. You will notice that the lines of pull back gradually start to decrease as you continue to furl. *Severe pull back can damage the boltrope.*

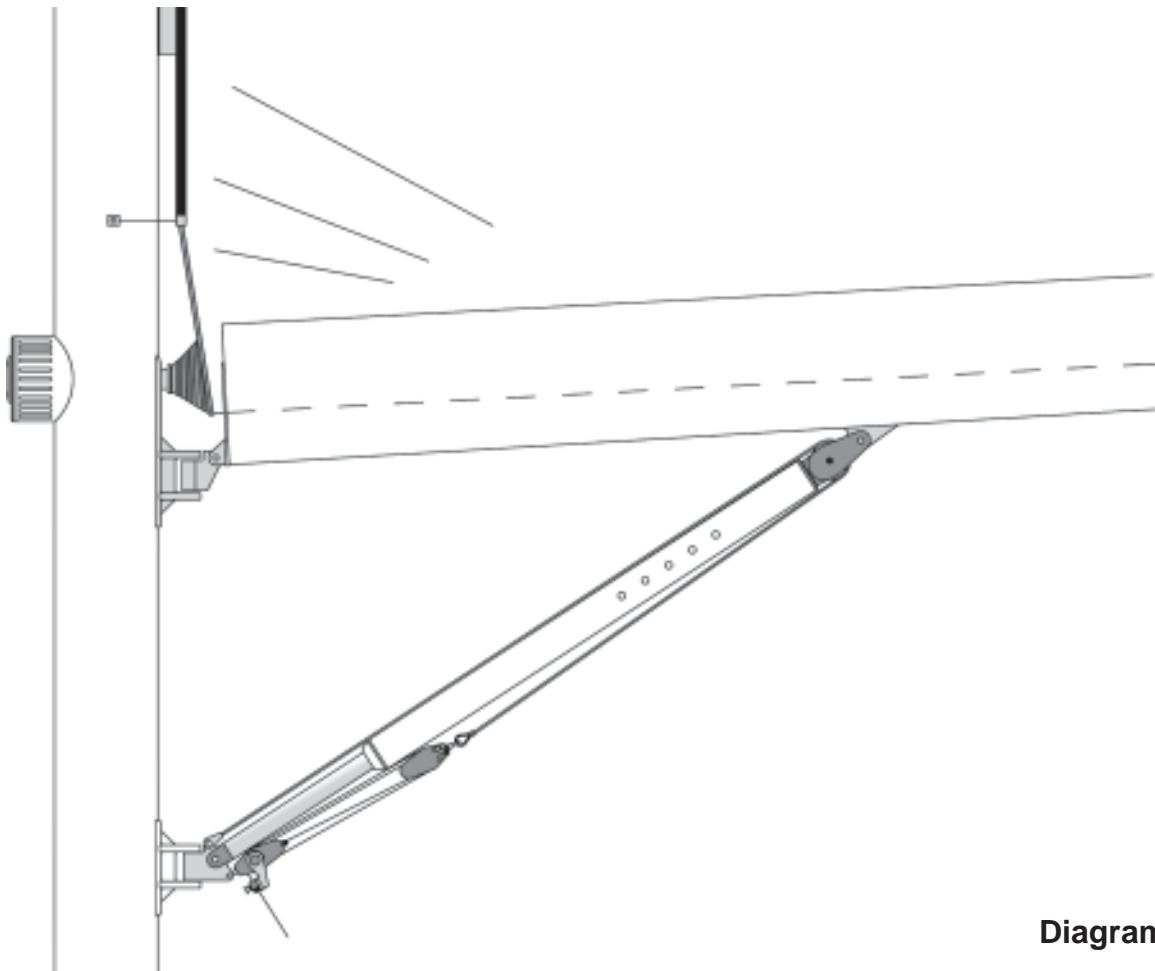

Leisure furl Tailing the Halyard

Sail works forward

In this instance increase the resistance on the main halyard, also ensure the sail is unloaded and the boom height is correct.

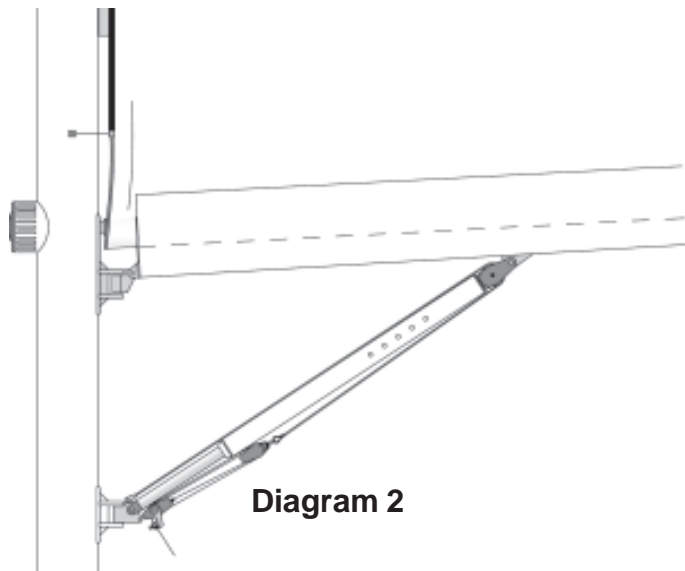

Do not release the main halyard in spurts, *see dia 3.*

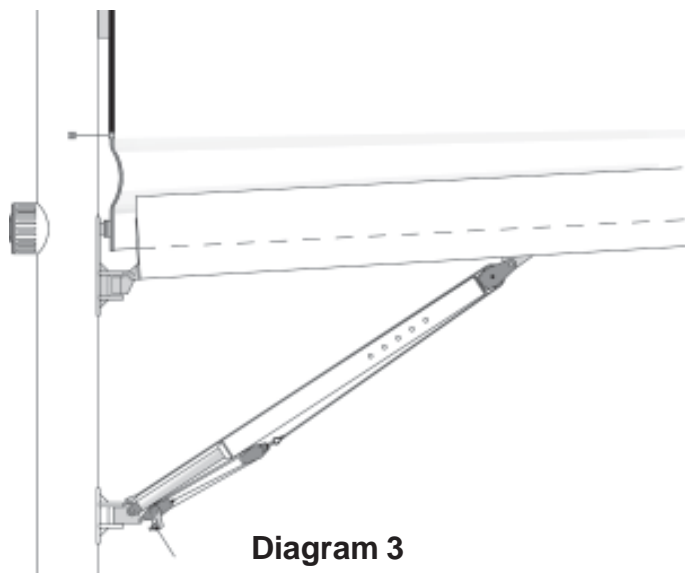

A consistent amount of halyard resistance is necessary for efficient furling. If the pull back does not appear to be controllable as explained consider the following:

- The boom height is not set correctly

- The sail has not been unloaded

- The sail is not positioned correctly on the mandrel *see sail adjustments*

Leisure furl Sail adjustments

Small adjustments to perfect the furl can be made as follows

- If the sail shows signs of pull back, without resistance on the halyard, make adjustment at the tack (A), pulling the tack closer into the saddle artificially creates luff round down low. Use the aft tack web if necessary for greater adjustment. This may cause slight distortion at the luff area around the first batten.
- Ease adjustment (C) to return fullness to the foot. Adjustment (B) will not need to be moved from its original setting.
- If the sail works forward as it furls, release adjustment (A) approximately 2". Leave adjustment (B) as it is and pull adjustment (C) out by 2". Also it may help to pull the topper on a little to increase the boom to mast angle to say 86.5°.

If these adjustments do not rectify the problem, sail modifications may be required. Contact an authorized dealer for further assistance.

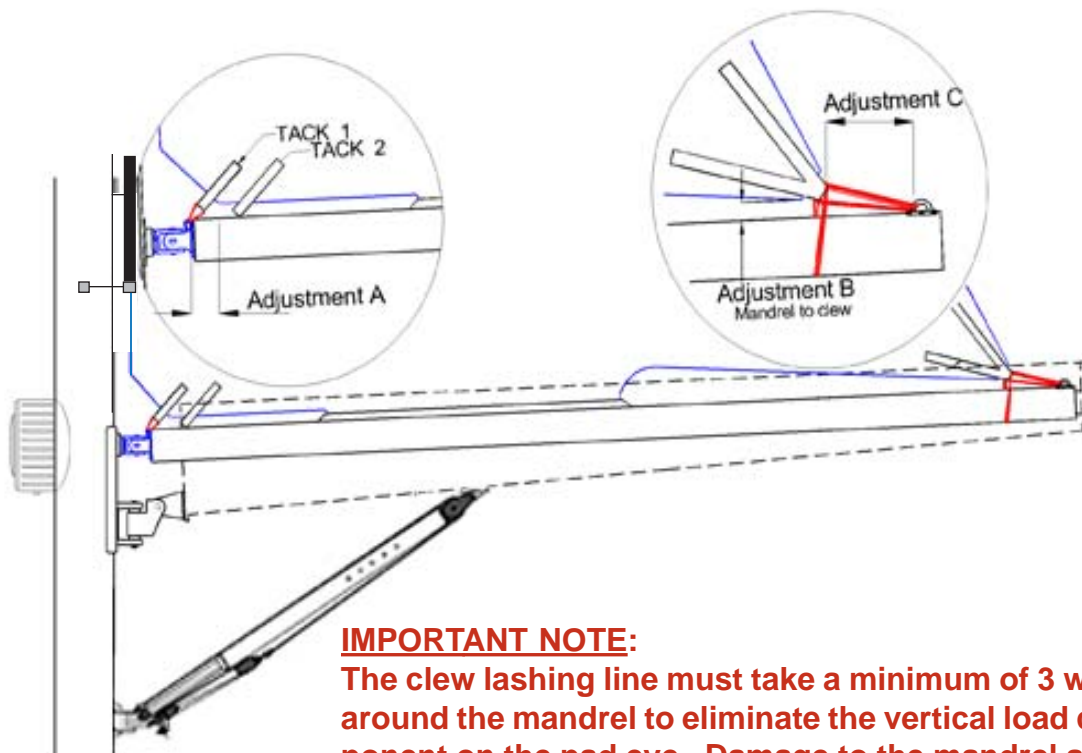

Diagram 4

IMPORTANT NOTE:

The clew lashing line must take a minimum of 3 wraps around the mandrel to eliminate the vertical load component on the pad eye. Damage to the mandrel and the foot of the sail WILL result if this process is not followed.

Leisure furl Flexible feeder limit line instructions

The limit line assembly consists of two stainless steel termination blocks and a fixed length of Spectra™ line which passes through the eye on the forward face of the luff feeder.

The termination blocks have been installed on the mast, port and starboard blocks at an equal distance from the aft face of the mast. The limit line should be loose enough to allow the feeder to flex athwartships, but not aft.

Each installation is a little different, and the desired amount of flex has to be determined by hoisting and furling the sail. The furling operation should be done several times with eyes on the luff of the sail. Ensure that the 87° boom angle is correct, then watch as sail the rolls into the boom. Furling should be checked at different angles to the wind, since this is the true test of the flexible feeder setup.

Once the termination blocks have been installed on the mast, the only way to effect the amount of flex in the unsupported portion of the luff track is to change the length of the limit line. If less flex is deemed necessary the line can be shortened. If a longer line is required for additional flex, Spectra™ line can be purchased from your local chandlery. Use a figure eight stopper knot in each end then trim the ends as necessary.

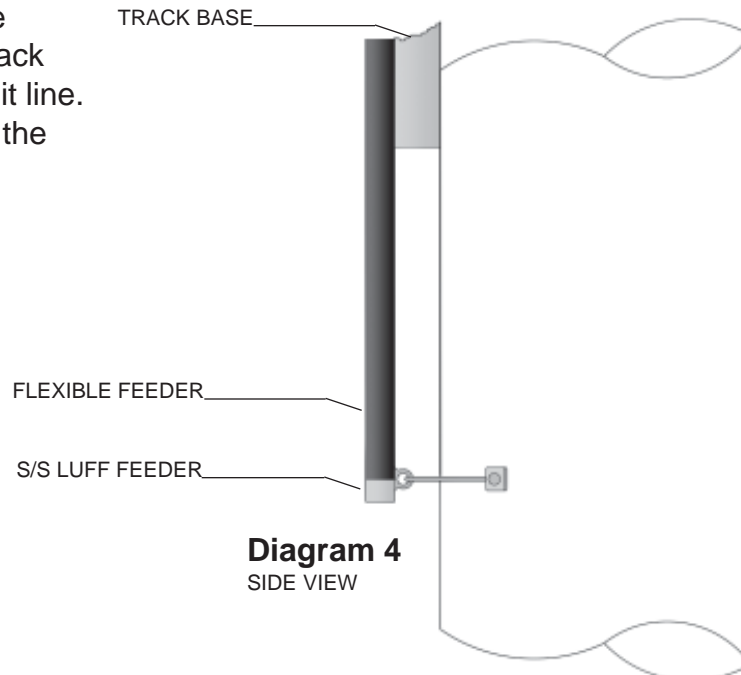

Diagram 4
SIDE VIEW

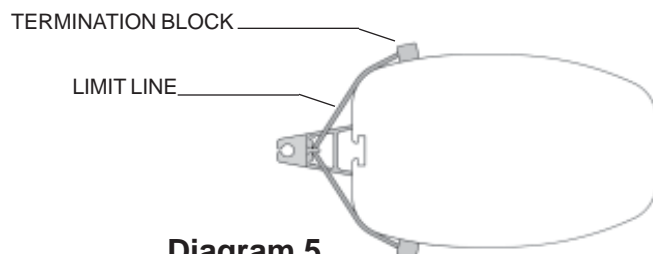

Diagram 5
BOTTOM VIEW

Use of the Ratchet Lock

A ratchet lock is built into the system to enable manual furling, without the fear of a counter rotation. It has proven useful also when reefed for extended periods. The ratchet will eliminate “creep” which is experienced on the furling line through stretch, and the rope pulling in on the other turns on the spool. Use of the ratchet will also remove load from the deck fittings. To disengage the ratchet lock, simply over tighten the furling line, as you disengage the locking pin.

Reef on a batten

Whilst possible to reef at any point of hoist, it remains desirable to reef on a batten as fullness may creep into the foot, and some efficiency lost for up wind sailing.

Luff tension

Luff tension is essential for efficient sail shape in an up wind heavy weather sail. It is a good idea to over tension, rather than under tension, as sail shape will suffer in the later circumstance.

Tension with the furling line

The system uses the main halyard as a means of hoisting the sail only. When luff tension is desired we normally use the furling line. Lock the main halyard off at the desired position, then pull against this with the furling line to achieve a flatter sail with tensioned luff.

Furling down wind

If it is necessary to furl down wind, we introduce a modified procedure to furling the Sail as was stated earlier.

- Square away to a broad reach, or flat run.
- **Pull the mainsheet in so the boom is approx. 45° to the centerline.**
- Release the vang a little and cause the boom to rise a bit, and pull in on the topping lift.
- Snub the main halyard off before releasing the main halyard rope jammer. Do not release any of the main halyard.
- Initiate furling without releasing any main halyard, then slowly allow the halyard to pull against the power of the winch. A lot of power will be required.

Leisure furl Trouble shooting

Sail cannot hoist

- Furling line rope clutch is not disengaged
- Locking ratchet is still engaged
- Furling line has a knot in it somewhere
- Sail has not been fed into the feeder correctly

Sail is hard to hoist

- Sail is partially loaded
- Main halyard or sail is catching somewhere. (Check head is not hooked on runners etc.)
- Furling line is catching somewhere
- Furling line is jammed in the spool

Sail cannot furl

- Main halyard rope clutch is not disengaged
- Main halyard is jammed somewhere
- Sail is caught somewhere – (*Would only occur if something is not set up correctly*)
Always remember that at any time the sail can be lowered by simply releasing the halyard

Sail pushes forward when furling

- Sail has not been unloaded
- Boom height is set to low
- Insufficient halyard resistance applied during the furl
- Sail is positioned too far forward on the mandrel

Sail pulls back excessively when furling

- Boom height is set to high. A small amount of extra height is not normally critical
- Too greater halyard resistance applied
- Sail is positioned too far back on the mandrel

Broken or damaged furling line, deck gear

- Bring the yacht head to wind, Insert a winch handle in the spool, engage the locking ratchet, ease the main halyard as the spool is rotated. At the desired level of hoist engage the main halyard rope clutch, and continue rotating the spool to tension the luff and flatten the foot. *It may be necessary to winch up the main halyard also under these circumstances.*

System makes a noise whilst at anchor

- Take the load of the topping lift or attach a shock cord from the support bracket to the topping lift, then pull tight.
- If the sail cover rattles at night, pull the cover along the boom to open.

Leisure furl MAINTENANCE SCHEDULE

LUFF TAPE: With a new sail on first hoist apply an even coat of “luff lube” to the full length of the sail on both sides during hoist, ensuring the head and batten ends are well coated.

After several weeks use, apply a further coat mainly to the head and batten ends.

Thereafter apply to head and batten ends approx. three times a season.

BEARINGS: Use Super lube or similar, once a season.

Aft spigot *Apply several drops through accessible holes.*

Forward Mast Bearing *Remove grub screws & apply several drops.*
Aft Mast Bearing

Universal *Apply several drops to accessible moving parts*
Gooseneck
Support bracket roller
Cover Rollers
Locking Ratchet

COMPONENTS: Check once a season.

Vang Tang *Ensure that all machine screws are tight & there is no sign of movement.*
Mainsheet Tangs
Preventer Tangs
Locking Ratchet *Ensure plunger is free & When disengaged is well clear of spool.*

ROPES: Main Halyard *Check for any signs of chafe at rope clutches, rope guides, sheaves etc*
Furling Line *Check retrieving line & where lines are joined.*
Sail Cover

RIG: Leisure Furl Track *Check the attachment slug nuts are tight and lubricate the sheave box at the mast crane.*

SAIL: Lashings *Check foot lashings for chafe.*
Inner batten ends *Check for any signs of chafe.*
Bolt rope

Leisure furl

Manually setting the boom angle

The easy way to set the boom is to hoist the mainsail to full height and substantially tension the luff. However, there could be occasions where it is felt there is a need to set the boom angle without the sail or there are suspicions that the tack angle is incorrect. If so, follow this procedure.

1. Fit the head slug to the track and transfer a mark on the universal out the same distance from the mast as the head slug. This distance should be just aft of the universal pins.
2. Place the tape on the universal mark and measure out the maximum distance you can achieve from the chart below (AB). Mark this point.
3. Pull the head slug up the mast with the tape attached until measurement (AC) is achieved. Carefully lock off the halyard ensuring the exact measurement is maintained.
4. Now swing the tape out to mark B and have the boom moved up or down until measurement (CB) intersects at point B. The boom is now at 87°.

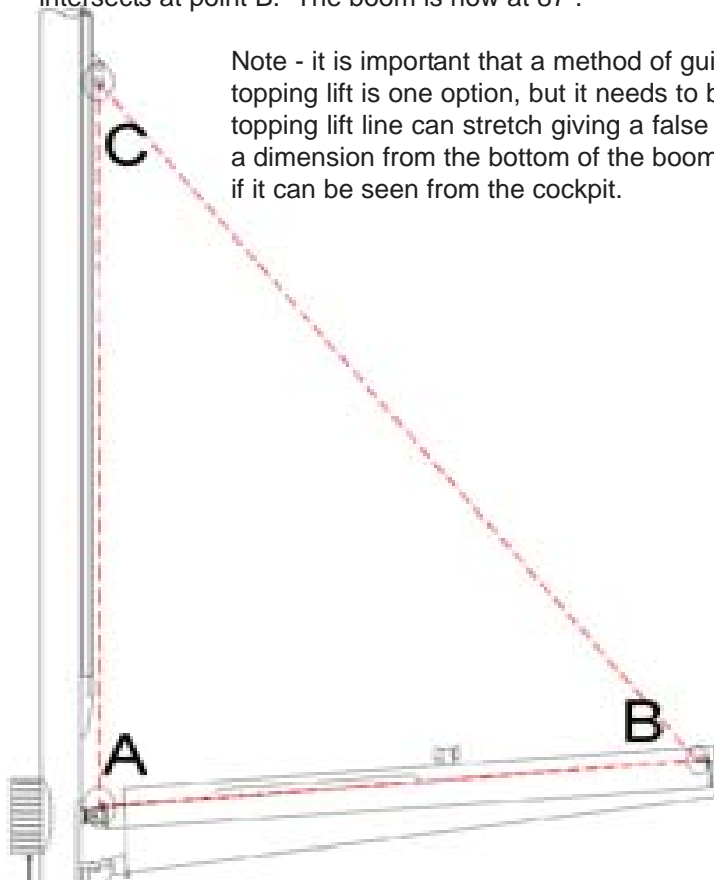

Note - it is important that a method of quickly confirming this set-up. Marking the topping lift is one option, but it needs to be checked from occasionally as the topping lift line can stretch giving a false reading. Additionally, you can establish a dimension from the bottom of the boom to the cockpit floor. Mark a solid vang if it can be seen from the cockpit.

Boom measurement - AB	Mast measurement - AC	Diagonal intersect measurement - CB
10'-0"	13'-4"	16'-3"
12'-0"	16'-0"	19' 5-7/8"
14'-0"	18'-8"	22' 8-7/8"
16'-0"	21'-4"	25' 11-7/8"
18'-0"	24'-0"	29' 2-7/8"
20'-0"	26'-8"	32' 5-7/8"
22'-0"	29'-4"	35' 8-3/4"
24'-0"	32'-0"	38' 11-3/4"

Must I always reef with a batten on the mandrel?

No. You can reef at any point, but the batten on the mandrel is the most efficient position in terms of holding the foot totally flat. The least efficient position is with the batten just outside the boom.

Must I go head to wind, to reef?

No. Under normal circumstances. As with a slab reef a close reach is the best point of sail to reef. It's desirable to have the main completely unloaded. However, if the boom is out more than 45 degrees the universal will bind and damage will result.

Do I need to snub the furling line when hoisting?

If the mainsheet is totally free, the furling line only needs to be snubbed if blowing hard. It's good practice to let it run through the hand while hoisting.

Does corrugation in the sail roll damage the sails?

Corrugations are caused by small sail faults, but do not cause any problems. They will gradually disappear as the sail softens up.

For racing, can I get degrees of fullness in the foot and still get luff tension?

Yes. Degrees of fullness can be achieved by pulling small amounts on the furling line but, if this is required, luff tension will need to be achieved with conventional cunningham at full hoist. Remember to ensure it's removed before furling.

Do I have foot control after reefing?

No, it's not required. If correct procedures are followed, the sail will always be totally flat on the foot. If more power is required, simply unwind more sail.

Can I still operate the system if my winch should fail?

Yes. Take controls to another winch or operate from the mast.

Can I still operate the system if I break a furling line or some of my deck gear fails?

Yes. Go forward with a winch handle and engage locking ratchet. Wind sail down with winch handle to desired position and tension with main halyard against ratchet.

What do I need to watch in very strong winds?

Only that the mainsheet is totally released and that the bow is not allowed to drop off far enough for the sail to start filling. Also make sure furling line is snubbed when hoisting and main halyard snubbed adequately when furling.

Can I use a solid vang in place of a topper?

Yes. Hydraulic vangs are quite satisfactory, but the angle has to be watched before furling. If using a gas or spring vang without a topper, there must be considerable upward pressure on the boom at its normal furling height, otherwise in a seaway the boom will start bouncing while furling.

Can I get away without a vang if I only cruise?

No. A vang is essential maintain 87 degree angle and to stop the boom riding up when furling.

Leisure furl Glossary of terms

Bolt Rope	The rope used in the luff tape.
Clew	The outer corner of the sail between the foot and the leach.
Cunningham	The rope that tensions the luff of the sail by pulling down.
Down Wind	With the wind aft of the beam.
Drive Shaft	The shaft that connects the mandrel to the spool in front of the mast.
Feeder	The block at the bottom of the sail track that guides the boltrope.
Flat Run	With the wind directly from the stern.
Foot	The edge of the sail that attaches to the boom.
Furling Line	The line that is used to lower the sail.
Gooseneck	The fitting attaching the boom to the mast.
Head	The top of the sail.
Head to wind	With the bow of the yacht directly into the wind.
Leach	The back edge of the sail between the clew and the head.
Leisure furl track	The sail track on the aft face of the mast.
Luff	The front edge of the sail closest to the mast.
Luff Lube	PTFE or similar based lubricant to be applied to the luff tape
Luff Tape	The tape at the sail luff which feeds up the sail track.
Topping lift	The rope that holds the boom up from the aft end.
Main Halyard	The rope that pulls the sail up the mast.
Main Sheet	The rope that pulls the boom in and out.
Mandrel	The tube that the sail furls around.
Outer Bearing	The bearing at the outer end of the mandrel.
Outhaul	The tensioning device on a conventional setup (not required with L/f as L/f has its own unique totally efficient foot tensioning system).
Ratchet	The mandrel locking device that is located at the bottom of the spool.
Roach	The area of sail that extends out from the leach.
Rope guide	The guide that centralizes the furling line in the spool.
Spool	The drum on the front of the mast that the furling line winds around.
Support bracket	The device in the middle of the boom that limits the flex of the mandrel.
Support bracket guides	The stainless steel rods that guide the sail around the support.
Tack angle	The angle between the foot and the luff.
Tack	The corner of the sail between the foot and the luff.
Universal	The swiveling joint that attaches the mandrel to the drive shaft.
Unload the main	Allow the mainsail (and mainsheet) to become totally slack.
Vang	The strut or rope purchase system that controls the boom angle.

Leisure furl Global Service

ASIA

KZ Marine Ltd
39 Vestey Dr, Mt Wellington
Auckland New Zealand
Ph +64 9 573 1939
Fax +64 9 573 1959
Email kz@xtra.co.nz

AUSTRALIA

KZ Marine Ltd
39 Vestey Dr, Mt Wellington
Auckland New Zealand
Ph +64 9 573 1939
Fax +64 9 573 1959
Email kz@xtra.co.nz

CARIBBEAN

FKG Rigging
Philipsburg, St Maarten
Netherlands Antilles
Ph +5995 44733
Fax +5995 42171
Email fkf@megatropic.com

ENGLAND

Romar b.v.
De Hagen 17, 8325 DB Vollenhove, Holland
Ph +31 527 241 735
Fax +31 527 244 181
Email romarbv@worldonline.nl

EUROPE

Romar b.v.
De Hagen 17, 8325 DB Vollenhove, Holland
Ph +31 527 241 735
Fax +31 527 244 181
Email romarbv@worldonline.nl

FRANCE

Gremco S.A.R.L.
1955 Ch De St-Bernard
06220 Vallauris Cedex
Ph +33 4 93 64 1919
Fax +33 4 93 64 8018

P.L.M. Yachting
70, rue des Saints Peres
75007 Paris
Ph +33 1 42 22 07 07
Fax +33 1 42 22 31 31
Email plemaout@aol.com

*Leisure furl International PO Box 22800
Otahuhu Auckland New Zealand
www.leisurefurl.co.nz*

GERMANY

Reckmann GmbH
SiemensstraBe 37-39
D-25462 Rellingen
Ph +49 4101 38490
Fax +49 4101 384950

HOLLAND

Romar b.v.
De Hagen 17, 8325 DB Vollenhove, Holland
Ph +31 527 241 735
Fax +31 527 244 181
Email romarbv@worldonline.nl

Proctor Holland b.v.
Middenhavendam 1
4511 AX Breskens
Ph +31 117 381 397
Fax +31 117 382 594
Email proctor@proctor.nl

ITALY

G & G rigging
Via San Giuseppe 15
20099 SESTO SAN GIOVANNI (MI)
Ph +39 2 24 00 980
Fax +39 2 26 22 1422

NEW ZEALAND

KZ Marine Ltd
39 Vestey Dr, Mt Wellington
Auckland
Ph +64 9 573 1939
Fax +64 9 573 1959
Email kz@xtra.co.nz

SPAIN

Yacht tech
C/Ca'n Valero 40
Poligono Can Valero 07011
Palma de Mallorca
Ph +34 9 71 20 0052
Fax +34 9 71 29 6504

A+ Rigging Mallorca s.l.
C/ Miguel de Cervantes,
14 Bajos
07181 Costa d'en Blanes
Ph +34 9 71 67 6713
Fax +34 9 71 67 5353
Email arigging@arrakis.es

UNITED STATES

Forespar Products Corp.
22322 Gilberto,
Rancho Santa Margarita, CA 92688
Ph +1 949 858 8820
Fax +1 949 858 0505
Email sparman@forespar.com
Web Site www.forespar.com

Important information for both installers and owners.

- **Ensure there are a minimum of 3 wraps of the clew lashing around the mandrel at initial setup and each time the sail is reinstalled.**
- **Do not raise the boom with the topping lift or vang more than 3 feet from the normal operating angle, as the mandrel will bottom out on the boom end plate and cause damage. If it is essential to do this, the mandrel must be disconnected from the universal.**
- **If the boom is dropped down to the deck for any reason ensure that the mandrel has not dropped off the aft end spigot before raising the boom again with the vang or topping lift.**
- **If it is necessary to furl downwind pull the boom in to 45 degrees before commencement. This decreases the load in the sail, gets the sail off the shrouds and spreaders and increases the efficiency of the universal.**
- **Ensure that the end float between the universal inner face and the inner bearing casting is no more than 1/16".**
- **If a topping lift only is being used to support the boom, tie a knot in the topping lift line aft of the rope clutch or cleat to ensure that if someone accidentally releases the topping lift cleat the boom doesn't crash down and cause damage or hurt someone.**
- **Ensure all track joints are smooth and radiused. The track entrance from the sail feeder is particularly important. See diagram 5.**
- **Ensure that there is nothing on the mast in the area that the sail rolls that could possibly cause sail chafe. This could include fittings around the side of the mast and trisail tracks.**



IMPORTANT NOTICE TO OWNERS AND INSTALLERS

Use caution when topping the aft end of the Leisure Furl™ boom.

As the aft end of the boom is raised, the MANDREL END GAP lessens.

Damage, including failure to the MANDREL or the AFT END STRUCTURE can result by compressing the aft end of the MANDREL into the AFT END STRUCTURE. The higher the boom is raised, the closer the aft end of the MANDREL comes to the AFT END STRUCTURE.

Monitor the MANDREL END GAP during the entire process of topping the boom above the 87° operational angle. Always prevent the mandrel from compressing into the AFT END STRUCTURE.

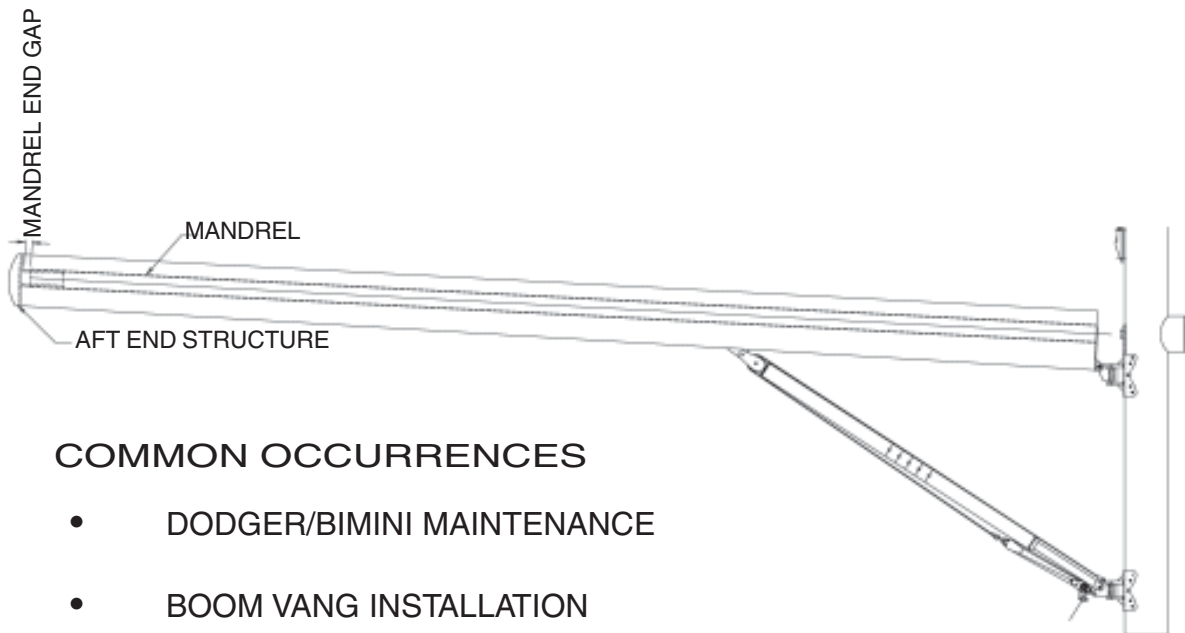

Leisure furl Boom angle tips

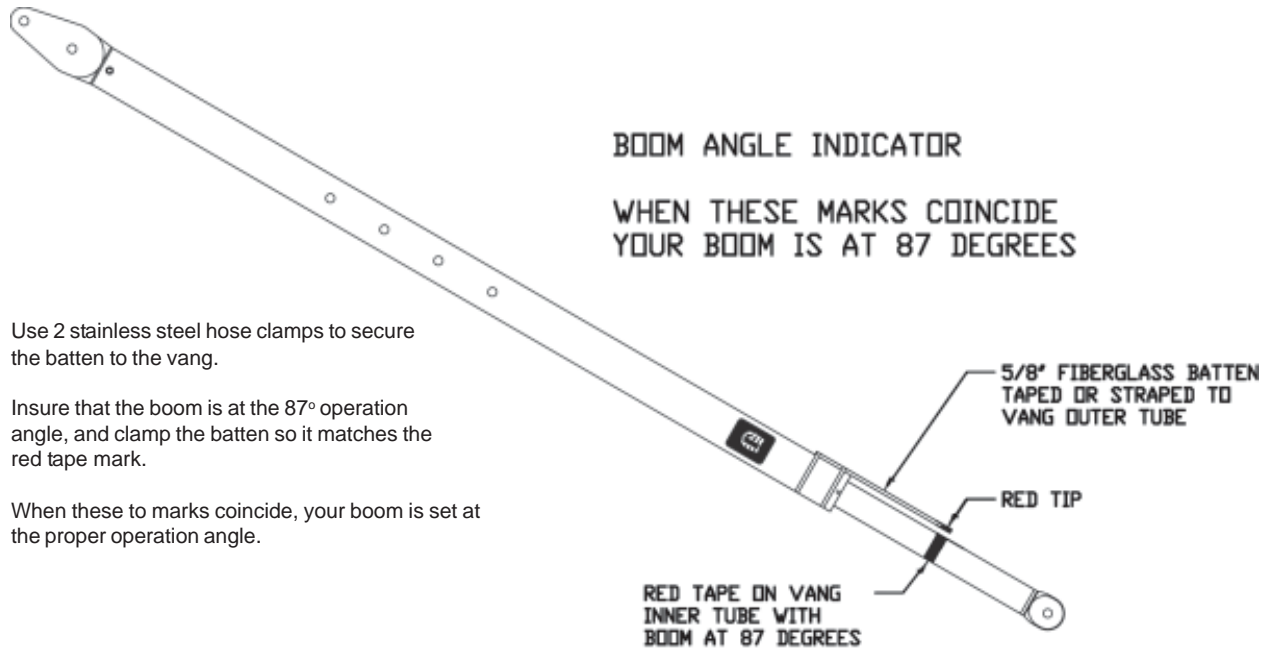

Use 2 stainless steel hose clamps to secure the batten to the vang.

Insure that the boom is at the 87° operation angle, and clamp the batten so it matches the red tape mark.

When these two marks coincide, your boom is set at the proper operation angle.

A clever boom angle meter for hydraulic vang^{*}

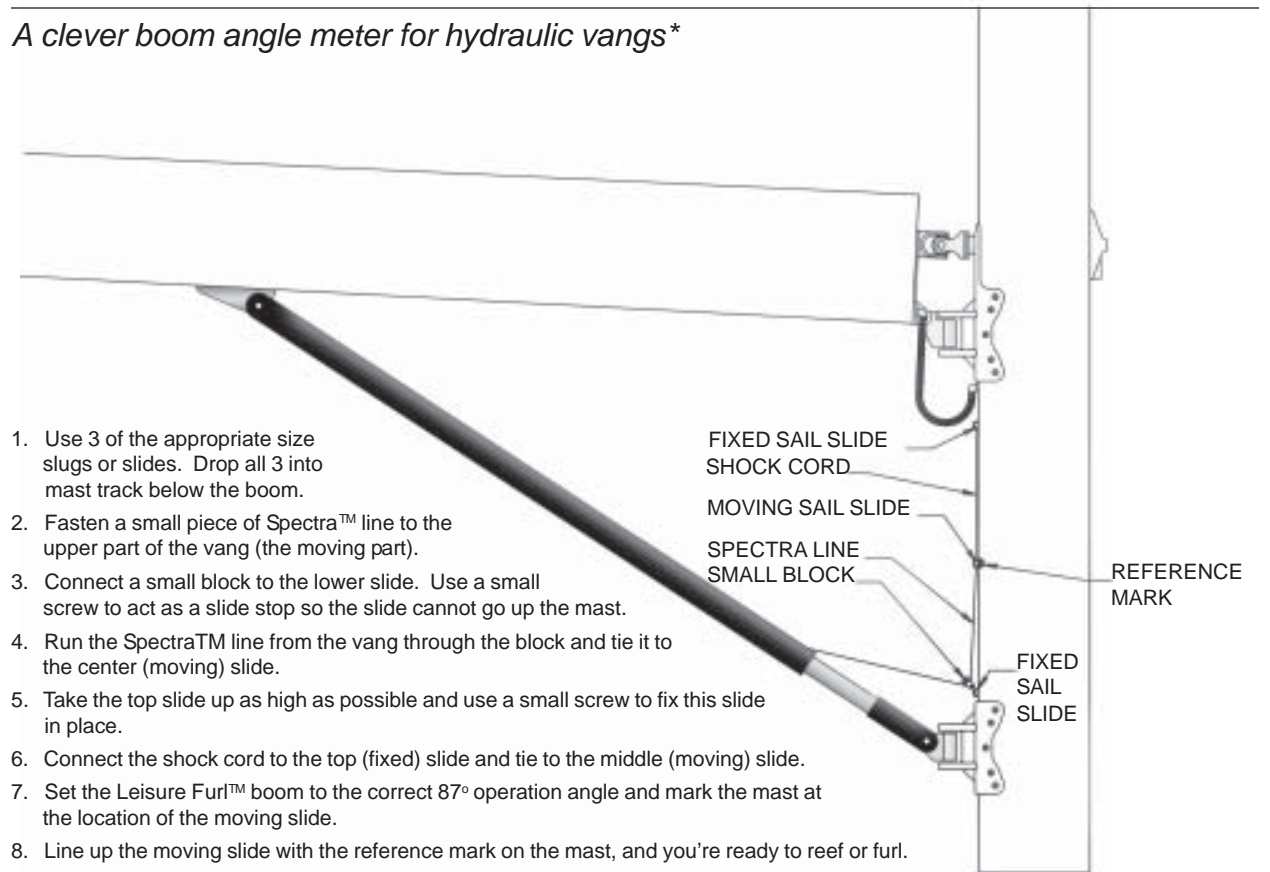

1. Use 3 of the appropriate size slugs or slides. Drop all 3 into mast track below the boom.
2. Fasten a small piece of Spectra™ line to the upper part of the vang (the moving part).
3. Connect a small block to the lower slide. Use a small screw to act as a slide stop so the slide cannot go up the mast.
4. Run the Spectra™ line from the vang through the block and tie it to the center (moving) slide.
5. Take the top slide up as high as possible and use a small screw to fix this slide in place.
6. Connect the shock cord to the top (fixed) slide and tie to the middle (moving) slide.
7. Set the Leisure Furl™ boom to the correct 87° operation angle and mark the mast at the location of the moving slide.
8. Line up the moving slide with the reference mark on the mast, and you're ready to reef or furl.

^{*}Thanks to John Baxter and Chuck Omalley of Doyle Sailmakers along with the guys at Atlantic Spars & Rigging for their efforts in developing this design. **22**

Accidental Gybes

IT IS THE OBLIGATION OF EVERY SKIPPER TO PREVENT UNSAFE AND DESTRUCTIVE BOOM MOVEMENT BY ENSURING THAT THE BOOM IS RIGGED FOR GYBE CONTROL

Rigging preventers and boom brake type systems

Accidental gybes happen in all conditions, even in light air a momentary lack of concentration can result in an accidental gybe. All booms should have some sort of control rigged when sailing deep off the wind. Again, even in light air conditions a boom can develop dangerous and destructive inertia when allowed to gybe freely. In-boom furling systems are heavier than standard booms, and it is more important to control their freedom of movement.

Preventer systems and boom brake type systems must be rigged to suit the layout of the boat, and all boats are different. Likewise the choice of which type of control system to use is an individual decision with varied opinions between experienced sailors.

A preventer is rigged from the bale on the bottom of the boom, and led forward to the toe rail. A snatch block can lead the line aft to a winch. If your boom can dip into the water at any time, a shock absorber must be included. **Shockles®** is a product which can be rigged into the preventer line to allow the boom to have some freedom of movement. If the boat cannot be steered back to the original gybe, a rigged preventer must be released after the gybe to get the boat controlled.



Shockles®
shock absorber
www.shockles.com

CONSULT WITH YOUR RIGGER FOR THE BEST METHOD TO CONTROL YOUR BOOM IT'S YOUR RESPONSIBILITY AND PRUDENT SEAMANSHIP

Another popular approach is to rig a boom brake type system which allows the travel of the boom at a slow rate during the gybe. These units do not require the immediate crew attention that rigged preventer must have. The brake usually rides on a line running perpendicular to the boom; when the boom brake is actuated, it grabs the line and either works as a preventer, or slows the boom's speed while gybing. The brake is actuated by tensioning the line upon which it rides.

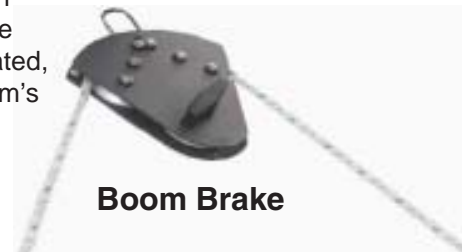

Boom Brake

Leisure furl Headboard Car (Not applicable to all systems)

Due to requests for a headboard car for large high leach load applications, a new aluminum luff foil system has been designed. Tracks in the sides of the extrusions accept the new car.

While the Leisure Furl headboard car is designed to handle the high leach loads present on boats 50' LOA and above, it can be used on any offshore system fitted with the new aluminum luff foil. The car runs on Delrin® slide rods which provide ultra low friction and great strength. The drawing below has the dimensions necessary for adapting sail heads. A 1/2" diameter vertical pin (not shown) is provided for webbing head attachment. Two sizes, 6" and 8-3/8" cars, are available.

IMPORTANT NOTICE

WHEN FURLING THE SAIL, THE HEADBOARD CAR MUST NEVER BE LOWERED BELOW THE BOTTOM OF THE ALUMINUM LUFF BASE EXTRUSION ONTO THE UNSUPPORTED FLEX FEEDER. Any Attempt to hoist the sail with the car below the bottom of the base extrusion will cause unacceptable loads on the car and flex feeder which can result in damage. If the car is lowered below the base extrusion, it is important to relieve all of the lateral loads on the flex feeder so it is vertical, straight and in-line with the luff track. This may require temporarily disconnecting the sail from the headboard car. Carefully unfurl enough sail so the car is above the unsupported portion of the flex feeder, then operate the system normally.

HBC-1	8-3/8" Headboard Car Forespar®	P/N 866076
HBC-2	6" Headboard Car Forespar®	P/N 866078

