



RAILFAST #156006 324-FPH (7-8" & 1") FLAG POLE HOLDER

THE FLAG POLE HOLDER

The RailFast™ Flag Pole Holder is packaged assembled. It will be necessary to take it apart prior to installation on your railing. In doing so, you will readily see how it goes together, but please read the instructions through before starting.

INSTRUCTIONS

Unthread the bolt with the Allen Key supplied. Then pull off the flag pole base and rail clamp pieces from rail strap assembly.

Once apart, notice that the device consists of the following pieces per drawing below:

- | | |
|--|------------------------------------|
| 1) Allen Key (5/16") | 2) S/S Bolt & Washer (3/8-16 x 1") |
| 3) Flag Pole Base | 4) Rail Clamp |
| 5) Tension Pin | 6) Rail Strap |
| 7) Rail Shim (7/8" - not needed on 1" rails) | |

- Slide rail over your rail. FPH must be mounted on a horizontal rail.
- If the rail is 7/8" diameter, place the 7/8" shim in the inside of the "U" in the rail strap before placing on rail.
- Insert the tension pin, round end first, through the square hole, keeping the threaded hole of the tension pin at a right angle to the rail.
- Slide the rail clamp over the ends of the rail strap until snug against your rail.
- Slide on the flag pole base; then thread the bolt and washer into the base and tighten to maximum **hand** force. This will assure a tight, secure fit. Do **not** use any additional leverage device--maximum hand force is sufficient. Use **Loctite™** "Blue" #242 on the threads.
- Place your flag pole into the base and be sure it fits snug. If desired, and for additional safety, you can drill a small hole (1/4" maximum) in the side of the flag pole base and use a set screw to hold the flag pole into the base socket.

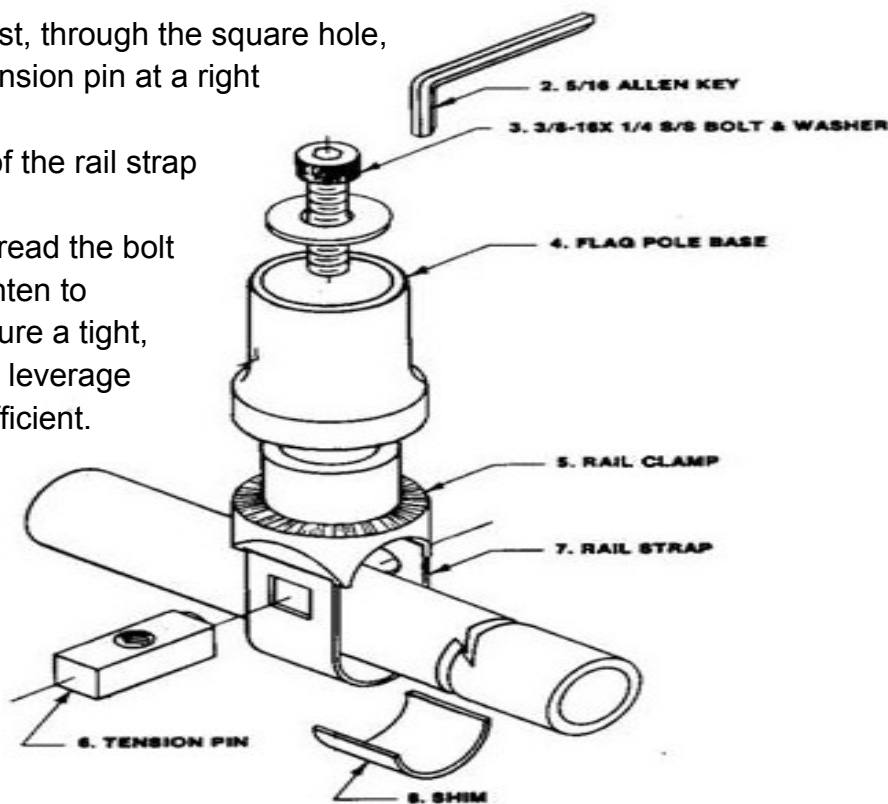

Forespar®

22322 Gilberto Rancho Santa Margarita, CA. 92688

Ph: 949-858-8820 Fax: 949-858-0505

www.forespar.com sales@forespar.com

www.facebook.com/foresparsailing www.twitter.com/foresparsailing