



*SAILBOAT EQUIPMENT
POWER BOAT EQUIPMENT
MARINE GRADE COMPOSITE PLUMBING*



FORESPAR®

MARINE PRODUCTS THAT PERFORM

VISIT OUR WEBSITE

www.forespar.com

We at Forespar are very proud of our website and we're working hard to make it better all the time. Our goal is to make **forespar.com** an excellent boating information resource for all your boating needs.

- Product Info and Specs
- How to Use
- How to Maintain

Have a look at the Knowledge section of our site and check the **Gold Information Tabs** below the product info on our pages. All of the information you need is in one convenient place. We believe the more you know about your equipment and systems, the more you'll enjoy your boating experience.

Made by boaters for boaters. Designed to help make your boating easier, safer, faster and a lot more fun.

The Forespar Team

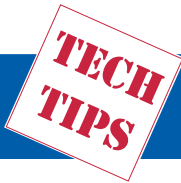

LOOK FOR THIS LOGO THROUGHOUT THE CATALOG FOR PRODUCT SPECIFIC ONLINE FEATURES:

www.forespar.com

ONLINE RESOURCES

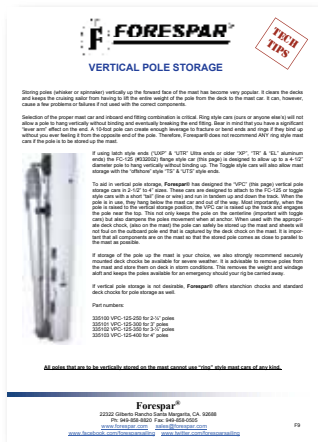

Sample Tech Tip Page

Build Your Knowledge with these online tools:

- **Tech Tips** – Learn from experienced boaters about your specific equipment
- **How-to Videos** – View professional videos to expand your **and your crew's** knowledge & skills
- **Installation Instructions** – Install your equipment properly and safely
- **Usage Tips** – Get the best use and enjoyment out of your equipment
- **Maintenance Tips** – Extend the life of your equipment for trouble-free operation



While Online Be Sure To Sign-up For Our Quarterly Newsletter

- Free Information
- Early Announcements
- One-of-a-kind Offers
- Subscriber-only Specials

Stay Current



facebook.com/ForesparSailing
facebook.com/LeisureFurl



twitter.com/foresparsailing



forespar.com/blog



forespar.com/videos.shtml

FORESPAR®

MARINE PRODUCTS THAT PERFORM

Fellow Boaters,

The name Forespar has been synonymous with quality boating products for over 47 years. We are committed to making fine products for both sail and power and we are proud to present you our current line of products.

Over the years our family owned company has built a team of dedicated marine professionals whose average company tenure is now over 15 years. Our salesmen, customer service personnel, welders, machinists and boating associates all have brought forth a steady stream of innovative marine products. And we are experienced boaters too – sailing, racing, and cruising. This creative input allows us to offer this diverse and extensive line of high-quality products. We are particularly excited to be increasingly incorporating lightweight, space-age materials into our products that will not corrode in the harsh marine environment.

To get our products to you we rely on hundreds of dealers here in the United States and over 25 agents from all over the world. We also offer our products through our state of the art website where you can view and learn about our products online whenever and wherever you like – including professionally produced how-to videos, tech tips, and installation info.

From our “93” series integrated thru-the-hull remote operated ROV valves, to our state of the art carbon fiber Leisure Furl booms, our commitment to evolving marine products stands out now, more than ever. Made by boaters for boaters. Our motto has always been to build “Marine Products that Perform” designed to help make boating easier, safer, faster and a lot more fun.

Thank you for considering and purchasing our products, and please feel free to offer us any suggestion or comment to help us push our product line into the future.

Sincerely,

Scott Foresman
CEO



TABLE OF CONTENTS

ALUMINUM TUBING.....	13
ANCHORAGE STABILIZER -ROLL-X.....	24
AWNING POLES.....	9
BOOM VANGS.....	14
BOW SPRITS.....	24-25
CARGO MATE™.....	29
CHOCKS, LINE.....	19
CLEATS.....	19
DAVITS - NOVA DAVIT™.....	28
EXIT BOX.....	19
HOT SPOT MINI GALLEY®.....	27
HOYT JIB BOOM™ SYSTEM.....	27
JIB ROLLERS-SAIL SAVER.....	18
LIGHTNING MASTER™ (STATIC DISSIPATER).....	15
LANOCOTE® NEW.....	19
LABEL SETS.....	24
LEISURE FURL™.....	30-32
LIFTS - NOVA LIFT™, MOTOR MATE™.....	28-29
LIGHTS, MAST & LIGHT GUARD.....	15
LIGHTS, PERSONAL RESCUE.....	23
MARELUBE™ LUBRICANTS NEW.....	16
MAST CARS NEW.....	12
MOB POLES & HOLDERS.....	22-23
PLUMBING PARTS - MARELON®.....	36-50
BALL VALVES.....	38
DECK FILLS.....	49
DRAINS NEW.....	48-49
DRAIN PLUGS.....	49
ELBOWS.....	42
FLANGE SEACOCKS.....	40
FLOWTECH™ PERFORMANCE VALVES.....	50
HOSE CONNECTORS.....	42
INTEGRATED SYSTEMS.....	44-47
SINK WASTES.....	48
SMART ROV VALVES.....	39
SMART VALVES.....	39
TANK VENTS.....	48
THRU-HULL CONNECTORS.....	41
VENTED LOOPS NEW.....	43
WATER STRAINERS.....	50
Y-VALVES.....	43
POLE ADAPTING COLLARS.....	13
POLE CHOCKS.....	13
POLE END FITTINGS NEW.....	10-11
POLE MAST FITTINGS.....	11
RAILFAST® HARDWARE.....	26
REACHING STRUTS.....	9
REPLACEMENT PARTS.....	51
REFRESH DEODORIZERS NEW.....	51
REPLACEMENT MASTS & BOOMS.....	33
ROLL-X FLOPPER STOPPER NEW.....	33
SAFETY EQUIPMENT.....	22-23
SHACKLE GUARDS.....	18
SPINNAKER POLES.....	5-8
STEERING CONTROL ARM NEW.....	25
STROBE LIGHTS.....	23
T-TRACK.....	11
TABLE PEDESTAL SYSTEM.....	27
TEF 45™ NEW.....	17
TILLER EXTENSIONS NEW.....	20-21
TILLER LOCK-BOX.....	21
TRACK STOPS.....	11
TRUPLUG NEW.....	23
TURNBUCKLE COVERS.....	18
WHISKER POLES NEW.....	2-4
WHISKER POLE LOCK REPAIR KITS.....	3
WINCH, MARELON®.....	25

WHISKER POLES



Whisker poles are used for non-spinnaker class racing and short-handed cruising, or whenever downwind performance is desired without the use of conventional spinnakers. A properly sized and deployed whisker pole will allow the headsail to add considerable power and speed to downwind sailing. Telescoping whisker poles allow one pole to be used with furling headsails or multiple sized jibs and genoas on a given boat.



"It is the most important add on I have on Quetzal, really. I can't imagine sailing downwind without my whisker pole". I make offshore passages for a living and I count on my Forespar® whisker pole. It's an aluminum and carbon, telescoping model that gives me great flexibility when poling out my headsail. The pole is robust, well engineered and easy to set. When the wind pipes-up I'm able to keep sailing on a deep reach and if it builds more I simply furl the sail, adjust the pole length and keep blasting along.

John Kretschmer
Professional Passagemaker
Sailing Writer

By projecting the headsail out to weather and out of the mainsail's "wind shadow", the headsail can fill and stabilize. Without a whisker pole, the headsail will flop from side to side, limp and useless. The use of a whisker pole will allow "wing on wing" sailing dead downwind with surprising performance. In recent years, asymmetrical spinnakers have become "all the rage" in off-the-wind sailing. These sails are subject to the same dynamics as jibs or genoas as you turn closer to dead down wind or try to sail "deep".

The use of a whisker pole to hold out the clew of the asymmetrical sail will stabilize the sail in the same way as a conventional headsail.

Easy As 1 - 2 - 3

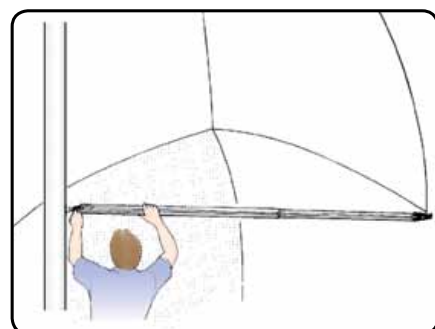
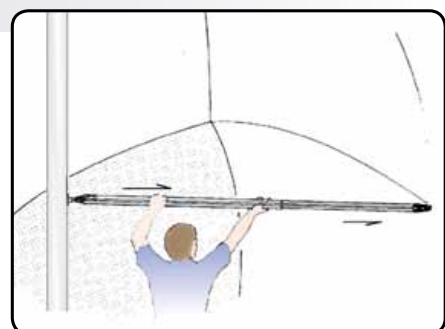
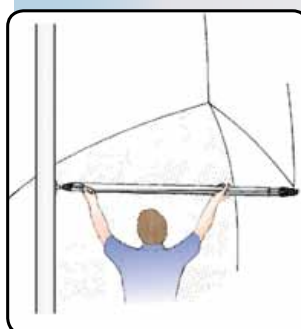

- 1 Un-cleat the Line.**
- 2 Pull Line out to extend the pole.**
- 3 Re-cleat the Line.**

WHISKER POLE SIZE RECOMMENDATIONS

WORKING JIB

Boat Length:	Light to Mod. Air	Mod. to Heavy Air
Up to 16 ft.	ADJ 4'-8'	ADJ 6'-12'
Up to 22 ft.	ADJ 6'-12'	HD 6'-12'
Up to 25 ft.	HD 6'-12'	HD 6'-12'
Up to 28 ft.	ADJ 7'-15'	ADJ 7'-15'
Up to 33 ft.	LC 10'-18'	LC 10'-18'
Up to 35 ft.	LC 12'-22'	LC 12'-22'
Up to 46 ft.	LC 13'-24'	LC 13'-24'
Up to 50 ft.	LC 15'-27'	LC 15'-27'
50ft and Over	Please contact Forespar for advise on ordering pole of this size	

GENOA

Light to Mod. Air	Mod. to Heavy Air
ADJ 6'-12'	HD 6'-12'
HD 6'-12'	LC 8'-14'
ADJ 7'-15'	ADJ 7'-15'
ADJ 7'-15'	LC 10'-18'
LC 10'-18'	LC 12'-22'
LC 12'-22'	LC 13'-24'
LC 13'-24'	LC 15'-27'
LC 15'-27'	Carbon Fiber Custom Poles
	Carbon Fiber Custom Poles

For Replacement Whisker Pole Parts See Page 47

TWIST LOCK WHISKER POLES

FOR BOATS 16 TO 30 FEET

SMALL TELESCOPING POLES (TWIST LOCK)

Telescoping models can be adjusted to any desired length and securely locked in position with an effortless twist of the inner tube. All small poles include strong corrosion-free Lexan end fittings and a Mast Pad Eye with stainless steel screws.

ADJ DL Style

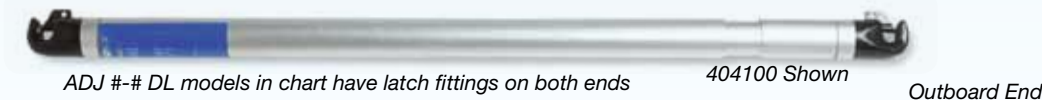

ADJ Style



Part No.	Model No.	Size/Weight
404000	ADJ 4-8	Telescopes from 53" to 93"/3 lbs. 1" outer diameter
404100	ADJ 4-8 DL	Double Latch - latch fittings on both ends
406000	ADJ 6-12	Telescopes from 72" to 134"/3 lbs. 1- 1/4" outer diameter
406100	ADJ 6-12 DL	Double Latch - latch fittings on both ends
404011	PE-1	Pad Eye Only
300026	ADJ 4-8	End kit
300027	ADJ 6-12	End kit

HEAVY DUTY TELESCOPING POLES (TWIST LOCK)

These telescoping whisker poles are heavy duty two section and three section aluminum spars which can be extended to lengths up to 15' and securely locked in position by an internal twist lock device. Poles feature self-latching Ultra Series™ fittings on the inboard and outboard ends Mast Pad Eyes (PE-3SF or PE-3SC - Page 11) are recommended.



Part No.	Model No.	Size/Weight
406300	HD 6-12-DL	Two sections extending from 79" to 138", 1-7/8" outer tube diameter. With self-latching fittings on both ends/8 lbs.
407101	ADJ 7-15-DL	Three sections extending from 83" to 169", 2 in. outer tube diameter. With self-latching fittings on both ends/8 lbs.
304015 UEF-3	HD 6-12 DL	Special - inboard (big) end only
304018 UEF-5	HD 6-12 DL	Outboard end only (small)
304057 UEF-3	ADJ 7-15 DL	Inboard (big) end only
304018 UEF-5	ADJ 7-15-DL	Outboard end only (small).

TWIST-LOCK REPAIR KITS*

To recondition any of our twist-lock telescoping poles, we offer lock repair kits. Complete instructions and all necessary parts are provided.



Part No.	Lock for:
400006	TAP's & ADJ 4-8's
400007	BHT's & TAP HD's
400008	ADJ 6-12
400009	HD 6-12
400010	ADJ 7-15 (Two-lock set)



TWIST LOCK WHISKER POLES

LINE CONTROL WHISKER POLES

FOR BOATS 20 TO 55 FEET

"COMBO" LINE CONTROL™ WHISKER POLES 50/50 CARBON/ALUMINUM

These Line Control™ Whisker poles offer just the right blend of aluminum and carbon structures to provide the racing or cruising sailor weight and cost savings. They have the strength and weight savings of carbon on the inner tube and the abrasion resistance, durability and cost savings of aluminum on the outer tube. They also feature Forespar's exclusive "Ultra" end fittings (UTS socket inboard and UTR trigger outboard) for further weight reduction and ease of maintenance.



LINE CONTROL™ WHISKER POLES

Line Control™ is a proven concept in telescoping whisker pole design. So unique, that full patent protection has been secured. Line Control™ is only available on Forespar® whisker poles. See the chart below for pole lengths and tube sizes. The system is simple, and makes the extension and retraction of poles quick and easy. And most amazing of all...the entire operation can be executed while being positioned at the mast. It is no longer necessary to go forward to adjust buttons of any kind - simply unclasp the line and extend or retract (never attempt to adjust while under load). It's quick and easy even with the largest poles. Topping lift attachment points are on all poles. Attachment to outer end is with end fittings jaw facing down.



LINE CONTROL WHISKER POLE MODELS, SPECS & FITTINGS

Part No.	Model No.	End Fittings		Recommended Mast Fittings	Collapsed Length / Weight	Max. Working Length	Tubing Diameters
		Inboard	Outboard				
401106	LC 10-18 EL-UXP	EL	UXP	PE-3SC, RC-125, FC-125	121.75"/17 lbs.	218.13"	2" & 2-1/2"
401107	LC 10-18 EL-UTR	EL	UTR	PE-3SC, RC-125, FC-125	121.75"/17 lbs.	218.13"	2" & 2-1/2"
402200	LC 12-22 UXP-UTR	UXP	UTR	RC-125, FC-125	148.50"/27 lbs.	265.25"	2-1/2" & 3"
402201	LC 12-22 UTS-UTR	UTS	UTR	T-125-S	148.50"/28 lbs.	265.25"	2-1/2" & 3"
800802	LC 12-22 UTS-UTR-CF	UTS	UTR	T-125-S	148.50"/19 lbs.	265.25"	2-1/2" & 3"
402203	LC 12-22 COMBO	UTS	UTR	T-125-S	148.50"/24 lbs.	265.25"	2-1/2" & 3"
403200	LC 13-24 UXP-UXP	UXP	UXP	RC-125, FC-125	162.00"/38 lbs.	272.00"	3" & 3-1/2"
403202	LC 13-24 UTS-UTR	UTS	UTR	T-125-S	162.00"/39 lbs.	272.00"	3" & 3-1/2"
800800	LC 13-24 UTS-UTR-CF	UTS	UTR	T-125-S	162.00"/24 lbs.	272.00"	3" & 3-1/2"
403203	LC 13-24 COMBO	UTS	UTR	T-125-S	162.00"/34 lbs.	272.00"	3" & 3-1/2"
405200	LC 15-27 UTS-UXP	UTS	UXP	T-125-S	182.00"/58 lbs.	324.00"	3-1/2" & 4"
405201	LC 15-27 UTS-UTR	UTS	UTR	T-125-S	182.00"/58 lbs.	324.00"	3-1/2" & 4"
800801	LC 15-27 UTS-UTR-CF	UTS	UTR	T-125-S	182.00"/32 lbs.	324.00"	3-1/2" & 4"
405203	LC 15-27 COMBO	UTS	UTR	T-125-S	182.00"/42 lbs.	324.00"	3-1/2" & 4"

*When selecting accessories for your pole, be sure to match the accessory size to the corresponding pole size.

TRI-REACHER™ WHISKER POLE

For boats 35'-42' loa. The new Tri-Reacher™ whisker pole has been developed specifically for use with Asymmetrical/Gennaker sails. Use of this 3-part telescoping whisker pole with these sails will allow deeper sailing angles and eliminate the need for constant jibing downwind. Collapses to 8' and extends to 21'. Ships UPS wt. 22 lbs



3" Dia. 2 7/8" Dia. 2 1/2" Dia.

Part No.	Description
408200	Tri-Reacher Whisker Pole

NEW

SPINNAKER POLES

We offer a complete and diversified line of spinnaker poles. We manufacture eight complete end styles from which we create a multitude of combinations to fit the needs of all sailors - racers or cruiser.

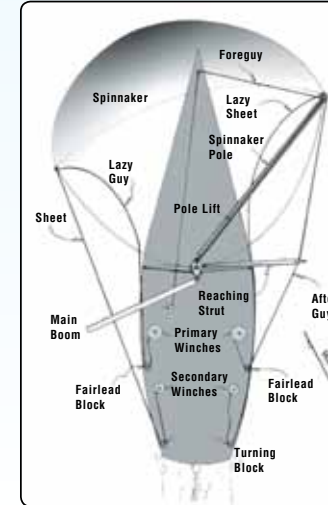

CUSTOM POLES

Our "customized" poles are built to specific dimensions. End fittings and tubing are available separately for those who wish to assemble poles to their own specifications.

Conventional Spinnaker Set-Up Varies by Boat Model, Size and Sail Type

DETERMINING POLE LENGTH

The length of your spinnaker pole is determined by the yacht's "J" measurement. This is the straight line distance from the front of the mast at deck level to the headstay. The "J" measurement is available from your sailplan, or contact **Forespar®** and we will be able to assist you in determining the proper length.

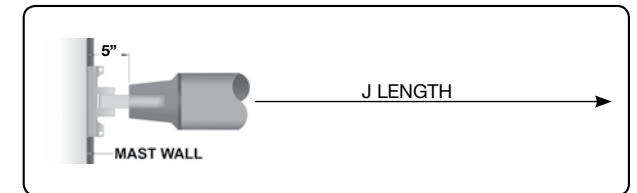

NOTE: For poles with our TS & UTS end fittings and using a Forespar T-125-S CAR, 5" is subtracted when given a "J" dimensions to establish pole length.

RETRACTABLE BRIDLE OPTION

For custom spinnaker poles 3" in diameter or larger only. Featuring internal outboard-end trip lines, and a retractable topping lift, this rigging allows the sailor to smoothly complete a spinnaker jibe without detaching the pole from the mast.

Part No.	Description
300032	Retractable Bridle Option

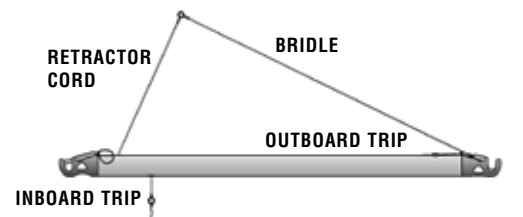

For A Complete Pole Size Recommendation Guide For Your Boat Goto:

www.forespar.com/techtips

HOW TO ORDER YOUR SPINNAKER POLE

Because there are a variety of options to choose from in ordering a spinnaker pole we need the person ordering the pole to fill out an order form detailing exactly how to build the pole and what features should be built in. There are 2 distinct forms, one for an aluminum pole and one for a carbon pole. Each is easy to fill in but lets us know what kind of boat the pole will be used on, what color paint (if any), what type of end fittings and many more choices.

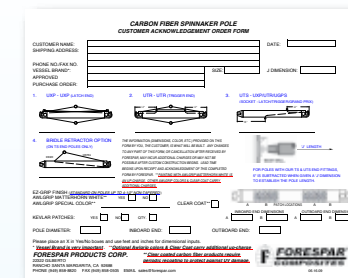

In order to give us the correct information to make your spinnaker pole, please call Forespar for the form or go to our website

For An Online Spinnaker Pole Order Form Go To:

www.forespar.com/orderforms

TECH TIPS

CARE OF END FITTINGS The most effective method of keeping deck hardware (e.g. pole ends, cams etc.) working freely is to wash them thoroughly with fresh water after every race or cruise. This is especially important when using spinnaker/whisker poles, tiller extensions or other telescoping equipment. Salt and sand that is not cleaned out can destroy the locks, cams, springs or rollers in a matter of months. Forespar® strongly advises against the use of lubricants on pole ends and telescoping poles. This can clog spring housings and ball bearings and can destroy twist-lock components. As a general rule, all fittings on deck, whether a dinghy or an ocean racer, should be maintained regularly. As previously mentioned, the best treatment is fresh water washing/flushing. This attention to maintenance will ensure that every fitting on your yacht will function at its best and attain a maximum performance life.

SPINNAKER POLES

SMALL BOAT SPINNAKER POLE KITS

Each kit includes anodized aluminum tubing. One end is loose so you can cut tubing to desired over-all length and then fasten end fitting with epoxy supplied. Less than 10 minutes to complete. Mini 6'7" kits include nylon latching end fittings, nylon lanyard, pad eye and epoxy kit.



Part No.	Model No.	Size/Weight
303600	Mini-6	1" dia.-6' Kit/4 lbs.
303700	Mini-7	1-1/4" dia.-7' Kit/4.5 lbs.

STANDARD SPINNAKER POLES

Our Standard Spinnaker Poles have a double bridle topping lift/foreguy system. Unless otherwise specified, all standard poles are supplied with the throat (jaw) facing upward. See price page for information regarding charges for special tubing.

(Requires a Forespar® T-125-S or AT-150-S Toggle Car - See Page 12)

Part No.	Model Number	Shipping Weight	Max Length (w/ends)	Description
304100	UXP-150-UXP	6 lbs.	7'-8"	ULTRA UXP fitting both ends.
304101	UXP-200-UXP	10 lbs.	9'-6"	ULTRA UXP fitting both ends.
304102	UXP-200-UTR	11 lbs.		ULTRA Trigger one end/ULTRA Piston other.
304103	UTR-200-UTR	11 lbs.	2" Dia.	ULTRA Trigger fitting both ends.
304104	UXP-250-UXP	14 lbs.	11'-6"	ULTRA UXP fitting both ends.
304105	UTR-250-UXP	15 lbs.		ULTRA Trigger one end/ULTRA Piston other.
304106	UTR-250-UTR	15 lbs.	2 1/2" Dia.	ULTRA Trigger fitting both ends.
304107	UXP-300-UXP	18 lbs.	13'-6"	ULTRA UXP fitting both ends.
304108	UTR-300-UXP	19 lbs.		ULTRA Trigger one end/ULTRA Piston other.
304109	UTR-300-UTR	19 lbs.	3" Dia.	ULTRA Trigger fitting both ends.
304110	UXP-350-UXP	33 lbs.	15'-5"	ULTRA UXP fitting both ends.
304111	UTR-350-UXP	33 lbs.		ULTRA Trigger one end/ULTRA Piston other.
304112	UTR-350-UTR	34 lbs.	3 1/2" Dia.	ULTRA Trigger fitting both ends.

OFFSHORE POLES (Requires a Forespar® T-125-S or AT-150-S Toggle Car - See Page 12)

Part No. Custom	Model Number	Shipping Weight	Kit Length (w/ends)	Description
302028	TS-300-GP	22 lbs.	14'	Socket Inboard/GP Outboard.
304115	UTS-300-UTR	18 lbs.	13.5'	ULTRA Socket Inboard/ULTRA Trigger Outboard.
304116	UTS-300-UGPS	19 lbs.	13.5'	ULTRA Socket inboard/ULTRA GPS Outboard.
302032	TS-350-GP	35 lbs.	15.5'	Socket Inboard/GP Outboard.
304117	UTS-350-UTR	33 lbs.	15'	ULTRA Socket Inboard/ULTRA Trigger Outboard.
304118	UTS-350-UGPS	34 lbs.	15'	ULTRA Socket inboard/ULTRA GPS Outboard.
302036	TS-400-GP	47 lbs.	19'	Socket Inboard/GP Outboard.
304119	UTS-400-UGPS	44 lbs.	18.5'	ULTRA Socket Inboard/ULTRA GPS Outboard.
302040	TS-450-GP	52 lbs.	21'	Socket Inboard/GP Outboard.
304120	UTS-450-UGPS	49 lbs.	20.5'	ULTRA Socket Inboard/ULTRA GPS Outboard.

CUSTOM OFFSHORE SPINNAKER POLES

Our Offshore Series spinnaker poles provide the serious racer with rugged, reliable and efficient equipment. These poles are designed to withstand the rigors of extended offshore racing.

Note: Due to the variety of personal preferences concerning bridle and topping lift rigging on offshore end type poles, no "standard" rigging is included on the poles below. If so specified, an end-to-end or a single topping lift can be supplied.

CARBON FIBER POLES

FORESPAR® SETS THE STANDARD IN CARBON FIBER DOWNWIND POLES

We have perfected the art of manufacturing carbon fiber equipment not only for the blue water yachts and racers but now for the recreational sailor as well. We have manufactured standard composite poles for over 10 years. We made our first carbon fiber mast in 1979, ten years before anyone else in the U.S. All Forespar® poles are manufactured in the U.S.A. and assembled in our California plant by professional riggers.

We are the world leader in standard composite whisker poles, spinnaker poles and reaching struts. Standard sizing is 2" - 6" diameter. Custom 6 - 12" diameter poles are also available. Spinnaker poles are offered in double tapered as well as parallel configurations. In addition, we custom design and make poles or bow sprits specifically sized for the head sail of your choice; code zeros, asymmetrical chutes, spinnakers or roller furling genoas. Typically a composite spinnaker pole will be 40% lighter than a similar aluminum pole yet almost 50% stiffer. Fixed length whisker poles and bow sprits are 50% lighter.

To ensure proper construction, a completed Spinnaker Pole Order Form must be submitted for each spinnaker pole.

For A Online PDF Form Go To: www.forespar.com/orderforms

TYPES OF CARBON FIBER POLES

Double-Tapered and Parallel Configurations Available



CARBON FIBER FIXED LENGTH WHISKER POLES

Forespar® carbon fiber poles available in deep epoxy clear coat or any Awlgrip color.

CUSTOM POLES

California "carbonwood" poles are faux spruce painted poles which give poles the rich wood grain look.



CARBON FIBER LINE CONTROL WHISKER POLES

Line Control pole inner tube is epoxy clear coat carbon fiber and the outer tube is Awlgrip white coated carbon fiber.

CENTER POINT POLES

Smaller diameter poles can be made with "center point" pick up "D" ring attachments



CARBON FIBER SPINNAKER POLES

Shown with optional Kevlar™ chafe protection.



CLASS LEGAL ONE DESIGN CARBON POLES

Part No.	Model No.
800124	J24
800104	Tartan 10, UXP-250-UXP CF
800204	Beneteau 36.7, UTR-300-UTR CF
800306	Mumm 30
800405	Beneteau 40.7

TECH TIPS

FOR ONLINE SPINNAKER POLE ORDER FORM GO TO:

www.forespar.com/orderforms

SPINNAKER POLES

CARBON FIBER SPINNAKER POLES & WHISKER POLES

Forespar's Composites Division has years of experience in the production of high performance poles for racing and cruising boats. Weight reductions over similar aluminum poles are typically 50% or better. Poles from 2.5" to 4.5" diameters are straight tubes unless custom 4.5" to 3.5" taper is requested. All 5" diameter and larger tubes have double tapered ends. Forespar® poles are produced from pressure cured intermediate modulus carbon fiber, and high performance epoxy resin systems.

Amsteel™ Trip Lines Standard On All Poles

Part No.	O.D.	Approx. Total Weight	End Fittings	Bridles	Maximum Length	Standard Finish
STRAIGHT NON-TAPERED TUBES						
800901	2.0"	4 lbs.	UXP-UXP	Double	10.0'	EZ Grip
800101	2.5"	4.5 lbs.	UXP-UXP	Double	12.0'	EZ Grip
800102	2.5"	4.5 lbs.	UTR-UTR	Double	12.0'	EZ Grip
800201	3.0"	8 lbs.	UXP-UXP	Double	14.0'	EZ Grip
800202	3.0"	8 lbs.	UTR-UTR	Double	14.0'	EZ Grip
800203	3.0"	9.5 lbs.	UTS-UTR	Double	14.0'	EZ Grip
800301	3.5"	11.5 lbs.	UTR-UTR	Double	16.5'	EZ Grip
800302	3.5"	11.5 lbs.	UXP-UXP	Custom	16.5'	EZ Grip
800303	3.5"	12 lbs.	UTS-UTR	Custom	16.5'	EZ Grip
800304	3.5"	14 lbs.	UTS-UGPS	Custom	16.5'	EZ Grip
800404	4.0"	20 lbs.	UTS-GP	Custom	18.5'	EZ Grip
800405	4.0"	21 lbs.	UTS-UGPS	Custom	18.5'	EZ Grip
800501	4.5"	25 lbs.	UTS-GP	Custom	22.5'	EZ Grip
800503	4.5"	26 lbs.	UTS-UGPS	Custom	22.5'	EZ Grip
DOUBLE TAPERED TUBES						
800502	4.5" to 3.5"		UTS-UTR	Custom	22.5'	EZ Grip
800504	4.5" to 3.5"		UTS-GP	Custom	22.5'	EZ Grip
800505	4.5" to 3.5"		UTS-UGPS	Custom	22.5'	EZ Grip
800601	5.0" to 3.5"		TS-GP	Custom	24.5'	EZ Grip
800701	6.0" to 4.0"		TS-GP	Custom	28.5'	EZ Grip
LINE CONTROL WHISKER POLES <i>Matterhorn white outer tube with clear coated inner tube standard</i>						
800802		19 lbs.	LC-UTS-UTR		12'-22'	Clear/White*
800800		24 lbs.	LC-UTS-UTR		13'-24'	Clear/White*
800801		32 lbs.	LC-UTS-UTR		15'-27'	Clear/White*

OPTIONS

- 800090 Retracting Bridle Option on 3" or Larger UTS Inboard
- 800091 Kevlar Patches (per 2 foot section)

FINISH OPTIONS

- 800096 U.V. High Gloss Finish - 2" thru 3-1/2"
- 800094 U.V. High Gloss Finish - 4" and Larger Poles
- 800093 AWLGRIP™ Color Coat on 2" - 3-1/2" Poles
- 800089 AWLGRIP™ Color Coat on 4" and Larger Poles

CARBON FIBER POLE FINISHES

We offers 3 distinctive pole finishes to chose from:

Our standard "EZ Grip" rough textured finish is the "price conscious" choice. The "High Gloss" UV resistant clear coated glossy poles offers some protection from the elements and also affords a very shiny and good looking pole.

The best protection and in some ways the best looking pole is an Awlgrip™ painted pole. A painted pole offers the best protection from the sun while matching any Awlgrip™ color in order to match the mast, deck or any other paint scheme on the boat.

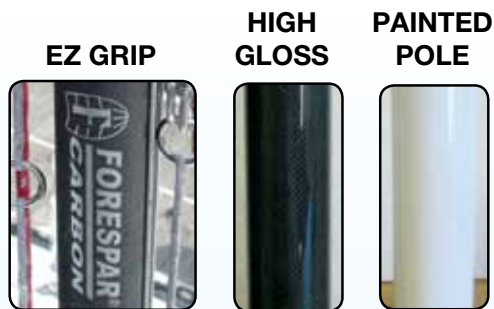

PADDED SPINNAKER POLE COVERS

Part No.	Model No.
882000	Small - Up to 3' O.D., 14' 6"
882001	Large - Up to 4" O.D., 18' 5"



REACHING STRUTS

SELF-LATCHING STRUTS

These struts feature the easy-latching inboard fitting which quickly and securely snaps onto the mast ring. Use of our stainless steel PE-3SF or PE-3SC mast pad eyes is recommended for proper fit.

RSO



UXP

Part No.	Model No.	Kit Length & Weight	Mast Dia.	Mast Fitting
341000	RS-200-UXP	5'7 lbs.	2"	PE-3SF or PE-3SC
341001	RS-250-UXP	6'9 lbs.	2 1/2"	PE-3SF or PE-3SC
341002	RS-300-UXP	7'10 lbs.	3"	PE-3SF or PE-3SC

Reaching Struts Available In Carbon Fiber

AUTOMATIC LOCKING STRUTS

This series of strut features our special socket-type end that automatically locks onto the toggle-pin mast fitting with an easy push on the strut. A simple release lever allows the strut to be quickly removed. This strut is especially valuable in competitive racing situations. The TMP mast fittings are required.

RSO



Automatic TS End (For TMP Fitting)

Part No.	Model No.	Kit Length & Weight	Dia.
343000	RS-300-TS	7'11 lbs.	3"
343001	RS-400-TS	9'17 lbs.	4"



TMP MAST FITTINGS FOR TS ENDS

Part No.	Description
343002	Aluminum
343010	Stainless Steel



TELESCOPING AWNING POLES



Ideal for boat awnings, our Telescoping Awning Poles are available in four length ranges to accommodate all boat sizes. Featuring our renown internal twist lock mechanism, the poles feature "eye" type end fittings. For larger boats we offer a special Heavy Duty option. Standard size poles have 7/8" and 1" diameter tubing. Heavy Duty poles are 1" and 1-1/8" in diameter.

Part No.	Model No.	Telescopes
503000	TAP 3-6	45" to 71"
504000	TAP 4-8	57" to 96"
505000	TAP 5-10	69" to 120"
506000	TAP 6-12	81" to 144"
505100	TAP 5-10 HD	69" to 120"
506100	TAP 6-12 HD	81" to 144"



POLE END FITTINGS

FORESPAR'S ULTRA SERIES™ END FITTINGS

Represents the cutting edge in spinnaker pole end fitting technology. Designed to be durable, high strength, very light weight and resistance to corrosion, the Ultra Series™ composite end fittings are perfect for aluminum or carbon fiber spinnaker poles and whisker poles. The Ultra Series™ is the sailor's choice for inshore and offshore racing and cruising. Available with or without triggers. Maximum LOA Boat Outboard End - 43'. Maximum LOA Boat Inboard End - 36'. All larger boats use GP Series.

- All Ultra ends require minimum 1.5 inch i.d. rings. Undersized rings damage ends and voiding warranty.
- Trip line is Spectra™ with terminal eyestraps included. Length is sufficient for standard pole lengths based on diameter.



UTR Trigger Style Ends

• Anti-rotational pin with **TRIGGER BALL** allows you to retract trigger end without using pole bridle. All UTR 3 & 3.5 trigger style ends also have adjustable spring tension screw.

Part No.	For Pole Model No.	Fits Diameter	Tube I.D.	End Fitting Length	End Fitting Weight
304060	UTR-200-EF	2.0"	1.870"	2.750"	6.97 oz.
304061	UTR-250-EF	2.5"	2.334"	3.125"	9.25 oz.
304062	UTR-300-EF	3.0"	2.835"	3.000"	11.92 oz.
304063	UTR-350-EF	3.5"	3.260"	3.625"	15.72 oz.

UXP External Trip Ends



Part No.	For Pole Model No.	Fits Diameter	Tube I.D.	End Fitting Length	End Fitting Weight
304054	UXP-150-EF	1.5"	1.370"	2.750"	6.97 oz.
304050	UXP-200-EF	2.0"	1.870"	2.750"	6.97 oz.
304051	UXP-250-EF	2.5"	2.334"	3.125"	9.25 oz.
304052	UXP-300-EF	3.0"	2.835"	3.000"	11.92 oz.
304053	UXP-350-EF	3.5"	3.260"	3.625"	15.72 oz.

UXTR External Trip Line Ends



Part No.	For Pole Model No.	Fits Diameter	Tube I.D.	End Fitting Length	End Fitting Weight
304090	UXTR-200	2"	1.870"	2.750"	6.0 oz.
304091	UXTR-250	2.5"	2.334"	3.125"	9.25 oz.

OFFSHORE SERIES GP & ULTRA SERIES™-GPS END FITTINGS

The UGPS end fitting comes with a stainless steel lined throat. As always, this deluxe ocean racing end fitting features a wide flared throat. Both the GP and UGPS ends also feature our proven spring loaded piston system with roller for positive lock and release.

All UGPS and GP ends for outboard pole end use only. Will not work with mast cars. All outboard ends are internal trip only.

UGPS Style



MAXIMUM BOAT LENGTH 60'

Part No.	For Pole Model No.	Tube Dia.	Tube I.D.	Weight w/o trip	Fitting Length
304021	UGPS-300-EF-ULTRA	3.0"	2.835"	2 lb 6 oz	5.00"
304022	UGPS-350-EF-ULTRA	3.5"	3.260"	2 lb 9 oz	5.625"
304023	UGPS-400-EF-ULTRA	4.0"	3.750"	2 lb 3 oz	5.625"
304024	UGPS-450-EF-ULTRA	4.5"	4.260"	3 lb 3 oz	5.1875"

GP Style



MAXIMUM BOAT LENGTH 75'

Part No.	For Pole Model No.	Tube Dia.	Tube I.D.	Weight w/o trip	Fitting Length
309030	GP-300-EF (Aluminum)	3.0"	2.835"	2 lb 12 oz	5.00"
309033	GP-350-EF (Aluminum)	3.5"	3.260"	3 lb 6 oz	5.625"
309035	GP-400-EF (Aluminum)	4.0"	3.750"	3 lb 14 oz	5.625"
309038	GP-450-EF (Aluminum)	4.5"	4.260"	4 lb 13 oz	5.1875"

ULTRA SERIES™ GRAND PRIX OUTBOARD END FITTINGS

Our ULTRA SERIES™ composite pole end fittings are a proven success. Their light weight and resistance to corrosion answer racing and cruising sailor's needs for strength and reliability. The Grand Prix ULTRA SERIES include sizes suitable for yachts sixty feet LOA. The ULTRA Grand Prix, UGPS, model with a stainless steel throat liner insert weighs only 38 ounces.

FOR REPLACEMENT PARTS SEE PAGE 47

AUTO SOCKET END FITTINGS TS & UTS

This unique "socket" type fitting automatically locks onto the mast toggle pin with a quick and easy push. The release is just as quick with a press of the lever (fits Forespar® mast toggle pins only).



TS Style

Shown with required T-125-S End Fitting Car (pg 12)

For Pole Fits Part No.	Model No.	Weight Diameter	Tube I.D.	w/o trip
309028	TS-300-EF (Aluminum)	3.0"	2.835"	1 lb 10 oz
304080	UTS-300-ULTRA	3.0"	2.835"	1 lb 4 oz
309031	TS-350-EF (Aluminum)	3.5"	3.260"	1 lb 13 oz
304081	UTS-350-ULTRA	3.5"	3.260"	1 lb 7 oz
405006	TS-400-EF (Aluminum)	4.0"	3.750"	2 lb 2 oz
309036	TS-450-EF (Aluminum)	4.5"	4.260"	2 lb 13 oz
304082	UTS-400-ULTRA	4.0"	3.750"	1 lb 7 oz
304083	UTS-450-ULTRA	4.5"	4.260"	1 lb 7 oz

POLE MAST FITTINGS

PE-3SF & PE-3SC PAD-EYES

To compliment our medium size Whisker Poles (LC 10-18); Forespar® designed the stainless steel PE-3SF & PE-3SC Mast Pad Eyes. Measuring 2-3/4" x 2", both pad-eyes have inside ring diameters of 1-5/8". PE-3SF is for flat mast surfaces. PE-3SC is slightly bent to better accommodate a curved mast.

Part No.	Model No.
400001	PE-3SF (Flat Base)
400002	PE-3SC (Curved Base)
400012	PE-3-SSF w/ struts (Flat Base)



T-TRACK 1-1/4"

Our T-track offers clear anodized aluminum T-track in one standard size. Track comes pre-drilled with alternating pin-stop and mounting holes. The base of the track is gently curved to better accommodate mast surfaces. Available lengths — 5' or 10'. The recommended fasteners are 5/16" x 3/4" Flat-head machine screws. 4" Hole spacing with "pin stop" holes

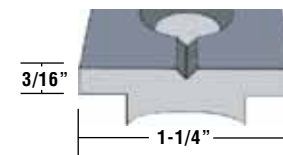

Part No.	Model No.
339007	T-Track 5' Length
339008	T-Track 10' Length

T-TRACK INSERT

These four foot sections of polypropylene inserts are for use on Z-Spar (Z Diffusion) masts found on many boats sold in the U.S. They will fill the slot found in the front center of the forward face of spars designed for cars not suitable for use with Forespar® end fittings. They provide a base for the mounting of standard 1-1/4" "T" track to allow the use of our various 1-1/4" mast cars. They are easily drilled and will not promote corrosion under the track.

Part No.	Model No.
339006	T-Track Insert (4 ft.)

MARELON TRACK STOP MS-125

MARELON construction prevents the cracking and shattering common with plastic stops. Sold Individually.

Part No.	Model No.
339009	MS-125

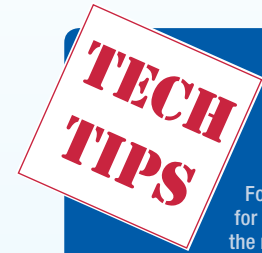
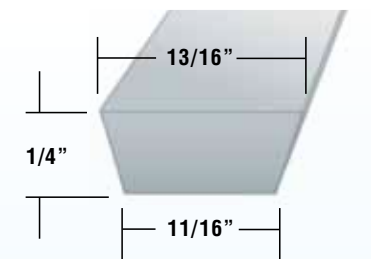

IMPORTANT: MAST CAR & EYE SIZES ON OLDER BOATS

Many masts on boats built through the 70's and early 80's came with mast pad eyes or ring cars for attachment of the spinnaker pole. These were fixed eyes or sliding cars with relatively small ring diameters. Some were as small as 1" I.D.

Forespar® "Ultra" series end fittings (both the UXP and UTR style) require a minimum of 1-1/2" I.D. rings for proper function. If the ends are used on rings less than 1-1/2" I.D. the jaws ("beak") can bind-up in the rings and with the leverage of an 8' pole, (or longer!) the ends will fail. Lesser diameter rings should be changed-out to avoid potential failure to ends due to insufficient clearance. Forespar® will not warrant ends that fail due to improperly sized rings on the mast performance life.

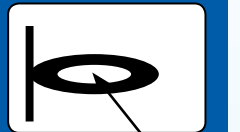

MINIMUM RING INNER DIAMETER MUST BE 1-1/2" OR MORE (UP TO 2" MAXIMUM) FOR PROPER FUNCTION OF FORESPAR END FITTINGS

MAST CARS

RING STYLE MAST CAR – RC 125

The ring and body of this unusually strong car is investment cast of 17-4 heat treated stainless steel to provide a superior product.

Compatible with our "UXP" and "UTR" pole end fittings. Ring I.D. is 1-5/8". The RC-125 is for 1-1/4" T-track and has a screw lock-pin, our special UHMW polyethylene slides inserts and provisions for up and downhaul shackles.

RC-125 car is NOT recommended for use with poles that are to be stored vertically up the mast.

Part No.	Model No.
331000	RC-125

Fixed Mast FC & Toggles

Want to add a spinnaker or whisker pole, but don't need a full track system on your mast? Our new Fixed Mast FC or TS Toggle Mounts are a perfect solution for boats 30 to 50 feet. The "FC" works with piston and trigger style end fittings (page 10) and the "TS" only works with the UTS & TS socket style inboard end fittings (page 11). The scissor base adjusts to fit mast thicknesses ranging from 2 1/2" to 5 1/2" wide. Polished stainless, it measures 7" long and has 10 - 1/4" staggered mounting holes.



Part No	Description
#332025	Fixed Mast FC Flange Mount
#333025	Fixed Mast TS Toggle Mount

HEAVY DUTY CAR — FC-125

These spinnaker cars are designed for the yachtsman who wants a safe, effective means of pole attachment for less than the price of the pin type car. The heavy duty FC-125 spinnaker car allows both vertical and horizontal movement while eliminating undesirable twisting motion of the spinnaker pole. The car slide and pole acceptance jaw are stainless steel.

Fits all standard 1-1/4" X 3/16" flat stainless or aluminum T-track. Recommended for "UTR" and "UXP" type spinnaker pole ends.



Part No.	Model No.
332002	FC-125

TOGGLE CARS 1-1/4" & 1-1/2" (For use with Auto Socket TS & UTS Ends - pg 11)

This car slide is offered both in stainless steel and hard coat anodized extruded aluminum and offers low friction movement due to UHMW inserts. The toggle-pin is stainless steel in each case. Toggle assemblies available separately see replacement parts page. Our strong 1-1/2" toggle spinnaker car is for boats approx. 50' to 70' LOA. Fits the standard Schaefer 41-12 1-1/2" track.



Part No.	Model No.	Track Size
333004	T-125-S (S/S Body)	1-1/4"
333020	Long Toggle Option	
333010	Toggle & Knuckle Assembly	
334100	T-150-S (Aluminium Body)	1-1/2"
331013	Replacement Runners (Sold in Pairs)	

To allow vertical storage on the mast of larger poles up to 6" diameter, specify our long toggle option. Our standard toggle works with poles to 4-1/2" diameter.

Measuring Poles With TS Or UTS End Fittings & T-125 Toggle Cars

For poles with our TS & UTS end fittings and using a Forespar® T-125-S CAR, 5" is subtracted when given a "J" dimensions to establish pole length.

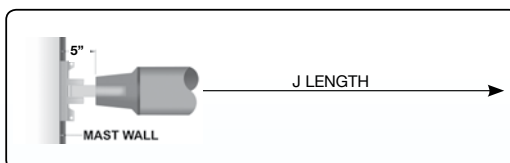

For Mast Car Replacement Parts See Page 47

TECH TIPS

VERTICAL POLE STORAGE

Storing poles (whisker or spinnaker) vertically up the forward face of the mast has become very popular. It clears the decks and keeps the cruising sailor from having to lift the entire weight of the pole from the deck to the mast car.

Selection of the proper mast car and inboard end fitting combination is critical. Ring style cars (ours or anyone else's) will not allow a pole to hang vertically without binding and eventually breaking the end fitting. Bear in mind that you have a significant "lever arm" effect on the end. A 10-foot pole can create enough leverage to fracture or bend ends and rings if they bind up without you ever feeling it from the opposite end of the pole. Therefore, Forespar® does not recommend ANY ring style mast cars if the pole is to be stored up the mast fitting on your yacht will function at its best and attain a maximum performance life.

FOR VERTICAL STORAGE USE ONLY MAST CARS; FC-125, T-125-S, T-150-S

FOR MORE INFORMATION GO ONLINE GO TO:
www.forespar.com/techtips

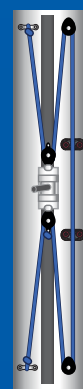

SPINNAKER POLE ACCESSORIES

ALUMINUM TUBING

Clear anodized to military specification (triple commercial). Prime marine alloy 6063-T6. All tubing sold in stock lengths.

Part No.	O.D.	Stock Lengths	Wall	I.D.	Wt./ Ft.	Part No.	O.D.	Stock Lengths	Wall	I.D.	Wt./ Ft.
500018	1-1/2"	22'6"	.065"	1.370"	.35 lbs	301065	3"	11'2"	.083"	2.835"	1.00 lb
500014	1-1/4"	12'	.050"	1.150"	.22 lbs	301072	3"	12'2"	.083"	2.835"	1.00 lb
408002	1-1/2"	7'2"	.065"	1.370"	.35 lbs	301019	3"	13'	.083"	2.835"	1.00 lb
301005	1-1/2"	7'6"	.065"	1.370"	.35 lbs	301063	3"	16'	.083"	2.835"	1.00 lb
500020	2"	21'6"	.065"	1.870"	.47 lbs	301030	3"	23'4"	.083"	2.835"	1.28 lb
408003	2"	7'2"	.065"	1.870"	.47 lbs	301061	3-1/2"	24'4"	.120"	3.260"	1.50 lb
401004	2"	9'1"	.065"	1.870"	.47 lbs	403004	3-1/2"	12'2"	.120"	3.260"	1.50 lb
301006	2"	9'4"	.065"	1.870"	.47 lbs	301059	3-1/2"	14'	.120"	3.260"	1.50 lb
301058	2-1/2"	20'2"	.083"	2.334"	.74 lbs	301024	3-1/2"	15'	.120"	3.260"	1.50 lb
301056	2-1/2"	9'	.083"	2.334"	.74 lbs	301003	4"	20'	.120"	3.750"	1.72 lb
301057	2-1/2"	11'2"	.083"	2.334"	.74 lbs						

* Custom Tubing is also available by the foot, call for pricing

VERTICAL POLE STORAGE CAR

This mast fitting is a simple solution to vertical pole storage problems. The VPC-125 retains the upper end of the stowed pole on the mast centerline. The chock slides on the track and eliminates rattle, vibration and binding of the pole end. All four cars fit 1-1/4" T-Track. Available in four sizes; this mast fitting can be rigged with our FC-125 and T-125 mast cars.



Part No.	Model No.
335100	VPC-125-250
335101	VPC-125-300
335102	VPC-125-350
335103	VPC-125-400

ADAPTING COLLARS

For sleeving Forespar® spinnaker pole end-fittings for use on larger diameter tubing, and other applications.



Part No.	Model No.	Adapts:
304049	AC-2 "ULTRA"	2.00" to 2.50"
304048	AC-3 "ULTRA"	3.00" to 3.50"
309020	AC-4 (Aluminum)	4.00" to 4.50"
309082	AC-5 (Aluminum)	5.00" to 3.00"
309083	AC-6 (Aluminum)	6.00" to 3.00"
304085	"ULTRA"	3.00" to 4.00"
304086	"ULTRA"	3.00" to 4.50"

DECK CHOCKS

Our deck chocks stow our spinnaker poles or whisker poles on the deck. We strongly recommend poles be stored on deck for heavy weather. The "Ultra" deck chocks will accept all Forespar® pole fittings. Designed and made from Marelon for rugged use and use a "snag-proof" low profile design.



Part No.	Model No.	Description
300002	DC-2 "Ultra"	(For UXP, UTR, GP & UGPS end fittings)
300013	DC-TS "Ultra"	(For TS & UTS end fittings)
300028	DC-TS-S	(Stainless steel, for UTS & TS ends)
300029	DC-2-S	(S. steel, for UXP, UTR, UGPS & GP ends)

STANCHION MOUNTED POLE CHOCKS

Clear the decks! Now you can stop stumbling over deck mounted poles. These chocks are molded from durable, weather-resistant urethane and mount easily onto 1" stanchions — no drilling necessary. For poles 2" to 3-1/2" in diameter. (Chocks are sold individually — two chocks are needed for each pole.) For spinnaker or whisker poles. Ideal for reaching struts!



Part No.	Model No.	For Pole Dia
300050	SC 200	2"
300042	SC 250	2-1/2"
300043	SC 300	3"
300044	SC 350	3-1/2"

MAST MOUNTED CHOCKS

(For Vertical Pole Mounting on the Mast)

Molded from durable high tech urethane, these chocks allow for stowing the pole vertically against the face of the mast. Off the deck and out of the way! Two MPC chocks mounted 2-3 feet apart will help stop the pole from rattling.



Part No.	Model No.	Description
300070	MPC 200	2" Mast Pole Chock
300071	MPC 250	2-1/2" Mast Pole Chock
300072	MPC 300	3" Mast Pole Chock
300073	MPC 350	3-1/2" Mast Pole Chock
300074	MPC 400	4" Mast Pole Chock

YACHT ROD™

The High Performance Spring-Loaded Mechanical Boom Vang

Precision design in three sizes. Excellent vang/boom support for performance cruising and racing. White powder coated aluminum & polished stainless steel. Supplied with spectra cable ready to add your tackle system. Your 4:1 equals 8:1 when installed on Yacht Rod™. Can be led to small winch for additional power. Spring return holds boom.

Brackets for mast and boom sold separately. Mast and boom fittings are listed below. Caution: Oversheeting or leaning heavily on aft end of boom can bend the boom or the Yacht Rod™. The main halyard shackle should be snapped to the outboard boom end, in port, to prevent damage to the Yacht Rod™.

"FOR RACING OR CRUISING"



Custom OEM Vangs Available



Note of Caution: Furling booms weigh as much as 3 times the weight of standard booms. Standard vang spring will not support their weight.

FEATURES:

- Eliminates need for boom topping lift
- Supports boom in light air, when reefing and lowering mainsail
- No gas spring to lose its charge
- Faster than hydraulics – No messy hydraulics to leak
- More efficient than conventional tackles
- Tubing is white coated anodized 6061-T6 aluminum and electropolished 316 stainless steel
- Precision machined 6061-T6 aluminum clevis ends, sheaves and Nylatron® bearings
- Precipitation hardened stainless steel spring with fast-pin adjustment — rated for over 1 million compressions.

YR Model Specs	YR-M	YR-L	YR-XL
Stroke	7"	11-1/2"	11-1/2"
Adjustable Length			
Pin to Pin (min.)	58 1/2"	66 1/2"	79 1/2"
Pin to Pin (max.)	70 1/2"	80"	93"
Adjustable Distance	12"	13-1/2"	13-1/2"
Pin Size	1/2"	5/8"	5/8"
Jaw Width	3/8"	11/16"	11/16"
Weight	9.8 lbs	17 lbs	19 lbs
Max. Return Force	600 lbs	1450 lbs	1450 lbs

YACHT ROD™ MAST & BOOM FITTINGS

YR-M Mast Fitting

YR-M Boom Fitting



YR-L & XLG Mast Fitting

YR-L & XLG Boom Fitting



Part No. Model No./Description:

352003	Boom fitting for YR-M
352103	Boom fitting for YR-L & YR-XL
352005	Mast fitting for YR-M
352104	Mast fitting for YR-L & YR-XL
352007	Harken 8:1 Tackle YR-M
352130	Harken 8:1 Tackle YR-L
352131	Harken 8:1 Tackle YR-XL

YACHT ROD™ - w/o HARDWARE

Model No./Description:	Part No.
YR Medium Yacht Rod for boats 34-40'	352000
YR Large Yacht Rod for boats 41-45'	352100
YR X-Large Yacht Rod for boats 46-55'	352101

COMPLETE YACHT ROD™ PACKAGES

YR-MEDIUM

Part No.	Package	Max. LOA	Includes
352050	1	40	YR-M Vang YR-M Boom Fitting YR-M Mast Fitting Harken Blocks & Tackle

YR-LARGE

Part No.	Package	Max. LOA	Includes
352160	2	45	YR-LG Vang YR-LG Boom Fitting YR-LG Mast Fitting Harken Blocks & Tackle

YR-EXTRA LARGE

Part No.	Package	Max. LOA	Includes
352165	3	55	YR-XLG Vang YR-XLG Boom Fitting YR-XLG Mast Fitting Harken Blocks & Tackle



FOR ONLINE TECH TIP ABOUT BOOM VANGS GO TO:

www.forespar.com/techtips

MAST LIGHTS

Forespar® offers two mast light systems. Model ML-1 deck light is designed primarily for installation on the mast just below the spreaders. Model ML-2 is a combination deck-bow light with separate switching, to be mounted on the forward part of the mast.

ML-1 & ML-2 feature durable molded polymer housings assemblies with adaptable wraparound mounting apron to accommodate virtually any mast curvature. For 12 V systems. Replacement bulbs available from Forespar® or most marine dealers.

For Replacement Parts See Page 47

SPREADER/DECK LIGHT - ML-1



- Lightweight - Rugged Composite Material
- Adaptable to Mast Radius for Ease in Mounting
- 20W Replaceable Halogen Type Bulb 1.4 amps
- Weighs 4 oz. - Measures 3-5/8" Vertically
- Provided with 6" of Twin-Lead Wire
- New Molded Body
- Available in black finish only

Part No.	Model No.
131000	ML-1
132035	Bulb
132009	Replacement bottom ring (Twist lock)

COMBINATION DECK/BOW LIGHT - ML-2



ML-2 #132000

This top selling light has been completely retooled for easy bulb replacement and brighter deck illumination using a new prismatic reflector.

- New molded black finish body
- Meets Coast Guard Requirements for Yachts Up to 65' LOA*
- Separate Switching
- 10 Watt Bow Light Bulb Is Easily Replaceable (WN-211) .8 amps
- Deck Light Features Identical to ML-1
- Provided with 6" of Triple-Lead Wire
- Weighs 7 oz. - Measures 5-3/4" Vertically

Part No.	Model No.
132000	ML-2
132025	WN-211 Top Bulb
132200	Stainless Steel Chafe Guard
132041	Complete top clear lens

*Copy of certification report available upon request from Forespar®.

STAINLESS STEEL LIGHT GUARD



Stainless Steel Light Guard protects mast lights and other mast fittings from line snagging

Part No.	Model No.
132200	Stainless Steel Chafe Guard



Works with Aqua Signal #254047-7 Combo Light

LIGHTNING MASTER™

Lightning Master™ Static Dissipaters lower the exposure to a direct lightning strike by controlling the conditions which trigger direct strikes by reducing the build-up of static ground charge and retard the formation of the ion "streamers" that complete the path for a lightning strike.

This is the same technology successfully employed to protect commercial broadcast and television towers. This lightweight (5.2 oz.) 21" long dissipater mounts to the masthead and extends vertically above all other masthead equipment.

We do not claim that this product is 100% effective in preventing a lightning strike. At the present collective level of understanding of the lightning phenomenon, no one can make that claim. This product does control the causes of lightning strikes and thereby reduces the incidence of direct strikes.

Part No.	Description
151100	Lightning Master™ Static Dissipater

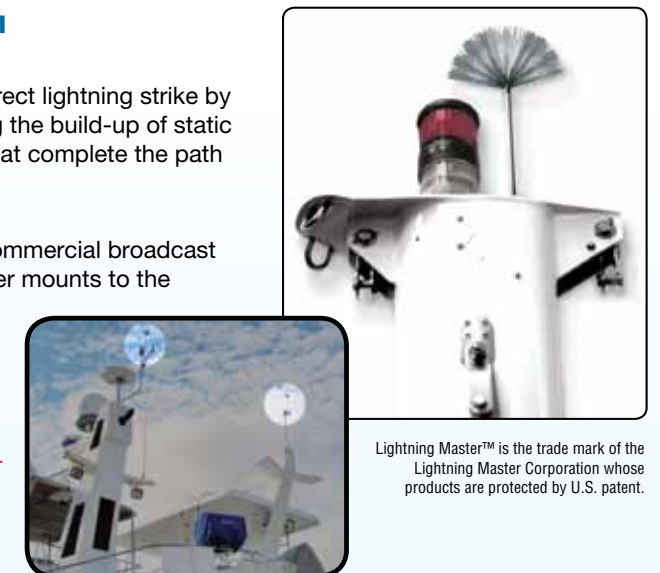

Lightning Master™ is the trade mark of the Lightning Master Corporation whose products are protected by U.S. patent.

Works Well on Power Boats Too!

MARELUBE™ LUBRICANTS

NEW

MareLube™ is Forespar's new family of three specifically formulated synthetic lubricants designed for various uses around your boat. Each contains PTFE (also known as Teflon®) and they work equally well in fresh or salt water. The family includes MareLube™ TEF 45™ for heavy wet use locations, MareLube™ EXTRA for general purpose lubrication needs, and MareLube™ Valve for marine valves and plumbing systems.

- Long Lasting PTFE Synthetic Lubrication
- Works Equally Well In Fresh Or Salt Water
- Safe On Rubber, Plastic and Painted Surfaces
- Formulated For Specific Uses For Maximum Effectiveness

MareLube™ Valve Lubricant

MareLube Valve Lubricant is an advanced lubrication formula designed to keep valve seals and balls working smoothly in marine plumbing systems. It is a clear, non-staining and nontoxic lube that is perfect for traditional bronze fittings, as well as all composite plumbing fixtures like Forespar's Marelon® parts.

Part No	Description
770050	4 oz MareLube Valve Lubricant



Non Toxic BioGradable

MareLube™ Valve Liquid

Liquid MareLube Valve Lubricant is a non-toxic, biodegradable formula that can be conveniently poured directly into your drain system to lubricate your valves and seacocks without disassembly. Available in an easy-pour 16oz bottle.

Part No	Description
770055	16 oz Liquid MareLube Valve Lubricant



MareLube™ Extra - General Purpose Lube

MareLube EXTRA is a great general-purpose marine lubricant perfect for those common uses around the boat. From hatches to sliding doors, EXTRA provides a long-lasting and water resistant PTFE lubrication barrier that controls rust and bi-metal corrosion. Available in 4oz jars, EXTRA is the perfect onboard lubricant to keep things working smoothly.

Part No	Description
770056	4 oz MareLube Extra



MARELUBE™ TEF45™

MAX 45% PTFE

MareLube™ TEF 45™ is a highly water-resistant synthetic lubricant grease containing 45% PTFE. This is the highest percentage PTFE available, which makes TEF 45™ perfect for heavy loads and bi-metal anti-corrosion applications like turnbuckles, spar fittings and motor lower units. TEF 45™ also works well at protecting against rust corrosion and anti-seize applications.



MareLube™ TEF45™

MareLube TEF 45 is a long-lasting lubrication paste that is perfect when you need a heavy-duty lubricant that can withstand high-load use in wet locations. Available in either 4oz or 16oz jars.

Part No	Description
770067	4 oz MareLube TEF45
770068	16 oz MareLube TEF45

MareLube™ TEF45™ Pre-Loaded Syringe Packs

Convenient pre-loaded syringe packs work great for those hard-to-reach applications where injection is needed. Available in 30cc and 6cc sizes - applicator brush included.

Part No	Description
770065	6cc MareLube TEF45 Syringe Pack
770066	30cc MareLube TEF45 Syringe Pack



MareLube™ TEF45™ Large Quantity Packages

MareLube TEF45 is also available in large quantity packages ranging from the 12 oz caulk tube to the 40 lbs bucket, these high quantity packages are great for large jobs and OEM applications.

Part No	Description
770170	MareLube TEF 45 - 12 oz Caulk Tube
770171	MareLube TEF 45 - 8 lbs Pail
770172	MareLube TEF 45 - 40 lbs Bucket

MARELUBE LUBRICANTS

MARELUBE TEF 45

SAIL SAVER™

SAIL SAVER™ JIB ROLLER - SR-3

These light weight, easily installed rollers can be used on the spreader tips or life lines to help skirt the foot of the jib. Sail Savers can also be used on backstays of catamarans or other boats with large roached mainsails. Center hole is 3/16" and can be drilled out to 7/16" maximum.

Simple installation with a small slotted screw driver. The unique locking collar is held in place with a small stainless steel set screw so there is no need for rigging tape or wire. The two halves "mate" (slide them together and they lock) and two clips are snapped on for added safety. Quick and simple. Easy to put on and also easy to remove.

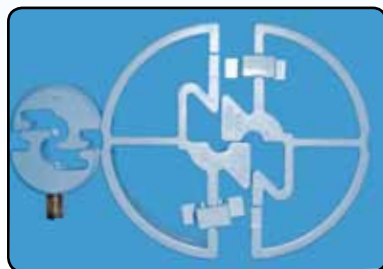

Sold in Pairs

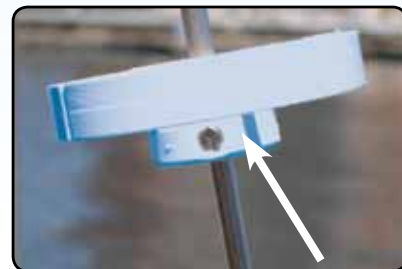

Locking collar with set screw.



Part No. 210020

JIB ROLLER - SR-2

Jib rollers for wire sizes 3/16" to 3/8". Extend the life of your genoa by reducing chafe on the spreader tips.

Jib rollers can also be used on lifelines for helping pass foot of jib over stanchions.

Sold in Pairs



Part No.	Model No.	Wire Size
210003	SR-2 (pr.)	Accepts wire 3/16" to 3/8"

SHACKLE GUARDS

Place a protective buffer between the spinnaker pole ends and your after-guy shackle. Made of high-strength polyethylene, these tough polymer guards are UV inhibited for long life. Shackle Guards can also be used on lifelines to skirt genoas.

Sold Individually



Part No.	Model No.	Size	Part No.	Model No.	Size	Part No.	Model No.	Size
300006	SG-1 White	2-1/4" Dia. X 3/8" ID	300085	SG-1 Red	2-1/4" Dia. X 3/8" ID	300090	SG-1 Green	2-1/4" Dia. X 3/8" ID
300007	SG-2 White	2-1/4" Dia. X 1/2" ID	300086	SG-2 Red	2-1/4" Dia. X 1/2" ID	300091	SG-2 Green	2-1/4" Dia. X 1/2" ID
300008	SG-3 White	3" Dia. X 1/2" ID	300087	SG-3 Red	3" Dia. X 1/2" ID	300092	SG-3 Green	3" Dia. X 1/2" ID
300009	SG-4 White	3" Dia. X 5/8" ID	300088	SG-4 Red	3" Dia. X 5/8" ID	300093	SG-4 Green	3" Dia. X 5/8" ID
300010	SG-5 White	3" Dia. X 3/4" ID	300089	SG-5 Red	3" Dia. X 3/4" ID	300094	SG-5 Green	3" Dia. X 3/4" ID

TURNBUCKLE COVERS



Deluxe aluminum turnbuckle covers give a fine yacht the "finished" look. Functional (keeps sheets from snagging on turnbuckle clevis pins) and durable, the turnbuckle covers come in three sizes to handle rigging from 7/32" to 1/2" wire diameter.

They are available in a white finish or clear anodized (silver) aluminum finish. The bases (bottom) come square and can be notched (to fit over chain plates) or cut to match your deck/shroud angle.

Sold Individually

Three Available Sizes

Small-(1-1/2" tubes) for 7/32", 1/4" and 9/32" wire sizes.

#210013 Anodized
#210010 White
Length - 22"

Medium-(2" tubes) for 5/16" and 3/8" wire sizes.

#210014 Anodized
#210011 White
Length - 26"

Large-(2-1/2" tubes) for 7/16" and 1/2" wire sizes.

#210015 Anodized
#210012 White
Length - 36"

LANOCOTE®

The Natural Choice of Marine Professionals

HOW DOES LANOCOTE WORK?

LanoCote works on these five basic principals: displaces water, absorbs corrosion, forms moisture barrier, penetrates and has high lubricity. LanoCote prevents dissimilar metal galvanization. LanoCote is extremely effective in preventing and stopping corrosion on all types of metals under all environmental conditions. Formulated to withstand salt water marine conditions, LanoCote® is particularly useful in preventing thread seizure due to all types of corrosion on boats and machinery.

Applied during assembly, LanoCote will greatly assist in easy dismantling years later. An example would be anchor shackles which are regularly immersed in salt water. LanoCote® also combats galvanization where dissimilar metals are fastened together, such as stainless steel fittings on alloy masts etc.

- Prevents Thread Freeze-up
- Combats Galvanic Reaction of Dissimilar Metals
- Seals Porous Surfaces
- Neutralizes Acids, Alkalies & Salts



Part No.	Model
770001	LanoCote® 4 oz. Jar
770002	LanoCote® 7 oz. Aerosol Spray Can
770003	LanoCote® 16 oz. Jar
770007	LanoCote® 8 oz. Pump Spray Bottle

LANOCOTE PROP & BOTTOM

ALL NATURAL FOUL RELEASE PROP & BOTTOM COATING

LanoCote Prop & Bottom is a revolutionary new way to keep your underwater surfaces clean. Simply wipe a thin coating of LanoCote Prop & Bottom onto foul prone surface for long lasting growth resistance and increased flow efficiency.

Part No.	Model
770035	LanoCote Prop & Bottom 16 oz. Jar
770031	LanoCote Prop & Bottom 1 Gallon
770030	LanoCote Prop & Bottom 5 Gallon



ASSORTED MARELON® CLEATS

Molded from high-strength Marelon®, Forespar's cleats have been used by manufacturers of yachts and power boats all over the world. Their strength, light weight and low cost have contributed to their increased use in the marine industry. The use of Marelon® allows our cleats to take up the curve of a deck without breaking, while maintaining strength and resisting abrasion — will not soften on hot days or freeze in winter.



3" - 8" CLEATS

Part No.	Model No.	Hole Dia.	Size
941018	MF 761/3	5/32"	3"
941016	MF 762/4	3/16"	4"
941013	MF 763/5	3/16"	5"
941014	MF 764/6.5	1/4"	6.5"
941015	MF 765/8	1/4"	8"

LOW PROFILE 6" CLEAT

Part No.	Model No.	Hole Dia.
941006	MF 766/6	1/4"

LINE CHOCKS — 3-1/2" & 6"

Part No.	Model No.	Hole Ctrs.	Hole Dia.
950001	MF 755	3-1/2"	3/16"
950000	MF 770	6"	1/4"

EXIT BOX

This new exit box is made for use with the new high-tech fibers. Forespar® uses this new exit on all trip lines and topping lifts. It is suitable for aluminum and ideal for carbon fiber poles as there is no metal to metal contact to promote corrosion. The axles are stainless steel molded into a strong Marelon® cheek with no moving parts.



Flange size: 3-1/4" L X 7/8" W
Cut-out size: 2" X 11/16"
Maximum line size: 1/4"
Uses two 3/16" flat head fasteners.

Part No.	Model
030016	Marelon® Exit Box

TILLER EXTENSIONS

TWIST-LOCK TILLER EXTENSIONS

The industry standards are set by Forespar's complete line of hiking sticks with designs and lengths to satisfy every sailor. Our telescoping models offer a choice of three excellent fastening devices: TFP (Quick-Release); SF (Sta-Fast™); and SL (Speed-Lock) our new composite universal.

A long time favorite of serious sailors around the world, the TFP (Quick-Release) model can be instantly fastened to the tiller by simply depressing the plunger and inserting the detent pin into the special tubular fitting supplied. Again, an easy push on the plunger and the hiking stick is released from the tiller. Stow it or take it home with you. It's fast, simple and secure.

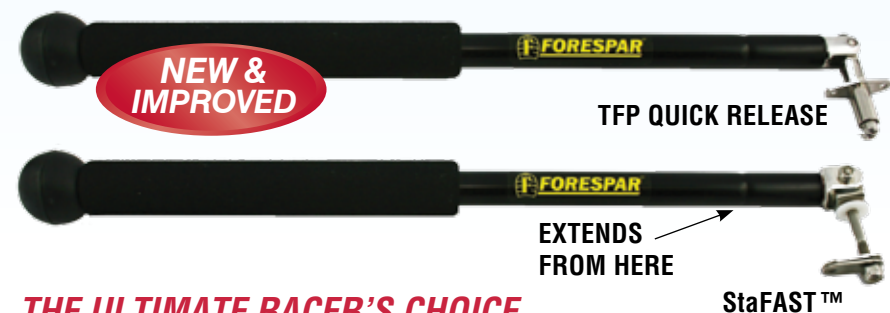

TILLER CLIPS

Exceptional strength tiller clips molded out of Marelon®



THE ULTIMATE RACER'S CHOICE.

New composite cam locks give our time tested twist lock tiller extensions a crisp, positive bite while freely unlocking with a quick turn of the wrist.

Part No.	Model No.	Telescopes	Tube Dia.
104016	TFP-S	19" to 32"	3/4" - 5/8"
104017	TFP-M	27" to 48"	3/4" - 5/8"
105110	STX 30"	Fixed	3/4"
105120	STX 36"	Fixed	3/4"
108100	SF-S	19" to 32"	3/4" - 5/8"
108101	SF-M	27" to 48"	3/4" - 5/8"

Part No.	Model No.	Size
941020	MF-671	3/4" Tubing Clip
941021	MF-672	7/8" Tubing Clip
941022	MF-673	1" Tubing Clip
941023	MF-674	1-1/8" Tubing Clip

"BIG STICK" CARBON FIBER TILLER EXTENSIONS

Our rugged, light weight tiller extensions are built to stand the test of time on any go fast dinghy or keel boat. They are simple yet elegant. Nothing to go wrong. 7/8" diameter shaft for a solid grip for either men or women. NO Frills, just an extension! Black only.

Part No.	Model No.	Length
102214	Big Stick Carbon	36"
102217	Big Stick Carbon	48"
102216	Big Stick Carbon	72"

All straight tubes so that they can be modified by each sailor to tailor fit his/her boat. Simply cut the tube to length on the outboard end. All come with our proven "speed lock" design (see page 27) for quick mount/dismount and easy replacement if necessary. The extensions are shipped loose for custom lengths to suit your class requirements.

"GIANT STICK" CARBON FIBER TILLER EXTENSIONS

The Big Stick's big brother, the Giant Stick offers all the features of the Big Stick with a larger diameter tube for a more comfortable and positive feel. 1-1/4" diameter shaft for a solid grip for either men or women. Black only.



NEW

Part No.	Model No.	Length
102225	Giant Stick, StaFast	36"
102226	Giant Stick, StaFast	48"

Part No.	Model No.	Length
102221	Giant Stick, Speed-Lock	36"
102222	Giant Stick, Speed-Lock	48"

Giant Stick
Big Stick
Conventional

Diameter Comparisons

THE BALL END & GOLF GRIP SWIVEL STICK

Forespar's economical fixed length tiller extension is now a better value. Featuring our removable Speed Lock (SL) rubber universal end fitting mounted on rugged 5/8" dia. black anodized aluminum tubing with rubber Ball End or Golf Grip style handle. For the small boat (up to 22' maximum) sailor. Available in four of the most popular lengths: 18", 24", 30" & 36".

BALL END

Part No.	Model No.	Length
102000	SW-18	18 in.
102001	SW-24	24 in.
102002	SW-30	30 in.
102003	SW-36	36 in.
102117	Replacement Speedlock Universal	
102119	Curved Base	
102120	Speedlock Base	

Tube Diameters 5/8"
(Uses Tiller Clip Part # 941020)

GOLF GRIP

Part No.	Model No.	Length
102008	SWG-18	18 in.
102004	SWG-24	24 in.
102005	SWG-30	30 in.
102006	SWG-36	36 in.
102117	Replacement Speedlock Universal	
102119	Curved Base	
102120	Speedlock Base	

Tube Diameters 5/8"

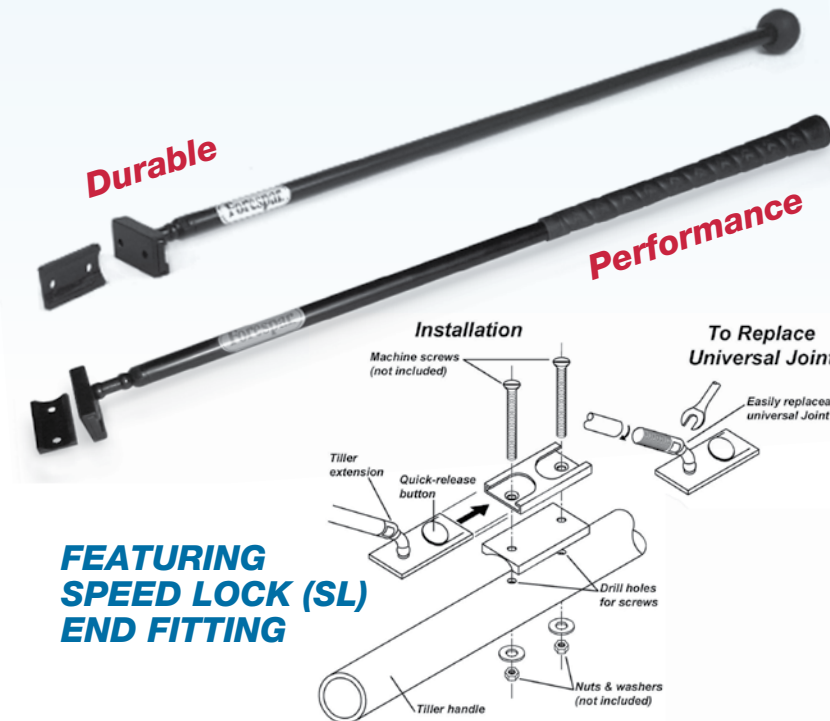

FEATURING SPEED LOCK (SL) END FITTING

END FITTINGS

StaFAST™ END FITTING (SF)

Patented design holds the tiller extension exactly where you leave it. No more sliding down out of reach (not sold separately). 5/16" X 2-1/2" bolt



StaFAST™STX & SF

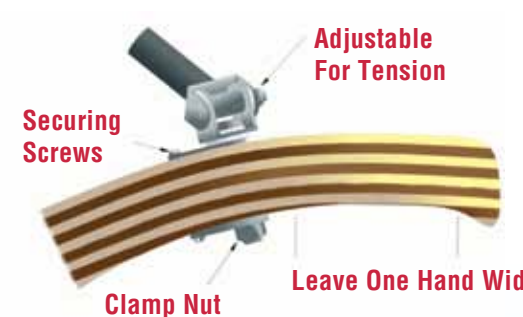

Not Sold Separately

TFP QUICK RELEASE



Part No.
104004 TFP Assembly Complete With Socket
104006 TFP Socket (receptacle only)

TILLER LOCK BOX — TLB

This inexpensive product turns any boat with a ball-grip Forespar® tiller extension into a boat with a simple, effective and adjustable tiller lock. Install one into your cockpit coaming and you have it in minutes!

Cut-out Dimensions :
3-3/8"w X 4-3/4"h X 1-1/2"d.

Part No.	Model No.
100000	TLB

Locks Your Boat On Course!

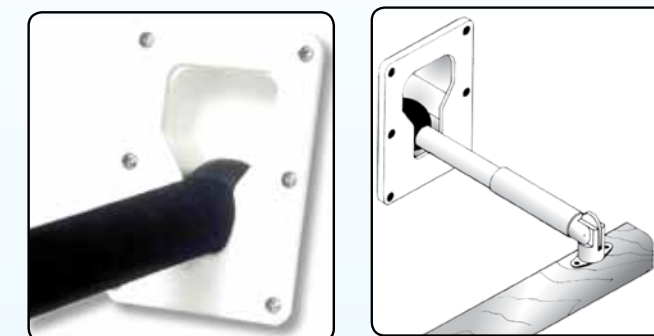

MOB SAFETY PRODUCTS

OVERBOARD GEAR NEEDS TO BE DEPLOYED QUICKLY...



... Because, at only 3 knots ...

... the person will be 50 feet away in 10 seconds, and ...

... in waves, the person will lose sight of the horseshoe buoy without an overboard pole!!

Our Man Overboard Poles are approved by both I.S.A.F. and Transpac Y.C. for offshore racing. These poles are constructed of the finest materials and reflect modern design and quality workmanship. The strong fiberglass shafts feature a highly visible yellow coating. The red and yellow flags are made of long lasting Dacron with a batten sewn in place to hold the flag in an open position. Now includes reflective tape to aid in night location.

We also use a special bright orange float which is made of a high impact, polyethylene jacket filled with closed-cell polyurethane foam. The float is slotted on the OP 120/150 model so it easily fits close to the backstay or life lines.

All poles are two-piece and feature a unique top shaft that can be custom sized by the user resulting in an overall pole length ranging from 11.5 to 15 ft. An epoxy kit is provided with each unit and no cutting is necessary. Simply telescope the top shaft to length desired and epoxy in place. A non-corrosive joining sleeve is standard to allow disassembly of the top shaft from the float for easy storage. The flag is included with Overboard Poles. Outside diameter of float is 4.25 inches.

OVERBOARD POLES — OP-120



DIMENSIONS

Part No.	Model No.	Overall Length		Butt to Top of Float	Weight	Top Half	
		Minimum	Maximum			Minimum	Maximum
202018	OP-120	142 in.	176 - 1/2 in.	64 in.	8 lbs.	78 in.	112-1/2 in.
202020	Top Pole Complete with Flag						
202026	Replacement Flag						

STERN TUBE OVERBOARD POLES

Functionally the same as model OP-120 overboard pole, the OPST is designed for boats with stern tubes. Outside diameter of float is 3.25 inches. Constructed from the same fine materials as our 'standard' poles.



DIMENSIONS

Part No.	Model No.	Overall Length		Butt to Top of Float	Weight	Top Half	
		Minimum	Maximum			Minimum	Maximum
202019	OPST-120	143 in	178 in	65-1/4 in	8 lbs.	78-1/2 in.	112-1/2 in.

WARRANTY RETURNS BASED ON UV EXPOSURE LIMITED TO 12 MONTHS

FLOATING STROBE WATER LIGHT- WL-1



Battery Not Included

Recent intense technological developments in the camera industry enable us to bring you this advanced strobe light at a significantly lower price.

Built to meet Code of Federal Regulations sub part 161.010; this rugged water light produces brilliant omni-directional (360 degrees) strobe flashes automatically when thrown overboard and is visible for miles at sea. When used with a 6 volt alkaline lantern battery (not included) it will flash at the U.S.C.G. required rate for over 52 hours and will still flash at least every 2 seconds after 7 days of continuous operation (meets U.S.C.G. requirements—46 CFR-161.010). A stainless steel mounting bracket is included. Dimensions are 11-1/2" long, and 4" maximum diameter, 1.85 lbs.

Part No.	Model No.
205102	WL-1
205130	Replacement Strobe

U.S.C.G. Approval #161.010/20/0

PERSONAL RESCUE LIGHT RL- 2

Our new approved personal strobe flasher should be an essential part of every yachtman's safety gear. Meets U.S.C.G. 161.012 when powered by an alkaline "C" battery replaced annually. Batteries are not included. Waterproof to 120 feet. Has a Velcro strap for attachment to upper arm or safety harness. Measures approx. 5" high, weighs only 5 oz. & flashes for over 24 hours.



Part No.	Model No.
202102	RL-2

Battery Not Included

OVERBOARD POLE HOLDER - 300-M

The Railfast® overboard pole holder holds the base of the pole. Easily mounted to the stern rail, close to the horseshoe bracket, it helps provide a complete safety system—with all man-overboard items located in close proximity for speedy deployment when time is of the essence. This unit is made of stainless steel and corrosion proof nylon, and comes with all mounting hardware.



Part No.	Model No.
156003	300-M-1" Rail
156023	300-M-1-1/4" Rail

FLAG TUBE OP-FT

To secure the flag on the overboard pole to the backstay or along the lifeline, our polyvinyl flag tube is superior to fabric flag-boots. Offering longer life and a faster release of overboard pole. Comes complete with fasteners and simple instructions. Maximum wire size = 3/8 in.



Part No.	Model No.
202013	OP-FT

TruPlug®

TruPlug instantly controls incoming water by automatically conforming to fill the shape of a hole. Whether it's from hull damage, hose failure, corroded thru-hulls or any other source, TruPlug's soft cone-shaped form fills the gap, giving you precious time in an emergency.



- More Versatile Than Wooden Plugs
- Easy to Use - Hand Compresses
- Works Up To 10' Below Waterline

Part No.	Model No.
150100	TruPlug

HOYT JIB BOOM™

Perfect Wing & Wing Trim of Your 100% Self-Tacking Jib

As your boat bears off downwind, and the sheets are eased, the Hoyt Jib Boom™ maintains precise control of the jib's leach. This results in remarkable performance improvement and ease of handling.

"The Hoyt Jib Boom™ is one of the best cruising innovations I have seen or used".
Ken Read • Vice Pres. North Sails



Sail More Easily & Efficiently

Proven on Over 1,000 Boats and Trans-Oceanic Passages

- Self Tacking Upwind
- Self Vanging Downwind
- White Powder Coated Base
- Up and Downwind Jib Control Based on a Simple & Effective Principle
- Leach Twist Perfectly Trimmed Downwind

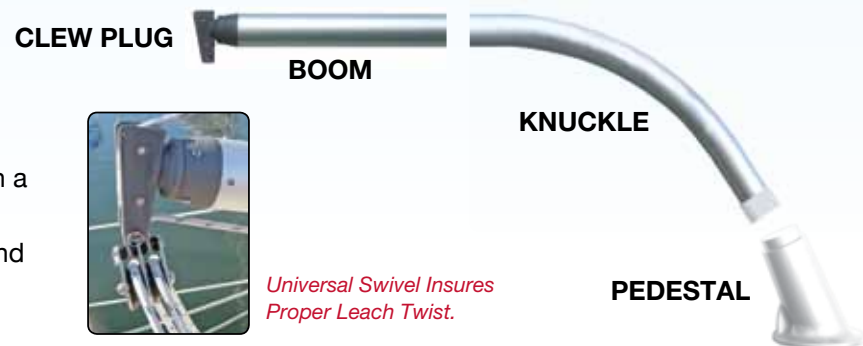

Universal Swivel Insures Proper Leach Twist.



The typical base placement (center of the pedestal base) is 10% aft of the headstay. This is not a critical location, but rather a "Rule of Thumb". Various obstacles can obstruct the pedestal base position.

All knuckles are bent to 57 degrees. All pedestals are set at 23 degrees. All angles are calculated on a perfectly flat and level deck. Wedges will be required on many installations to make up for deck camber. A universal black molded urethane wedge which can be cut to fit is available from Forespar®

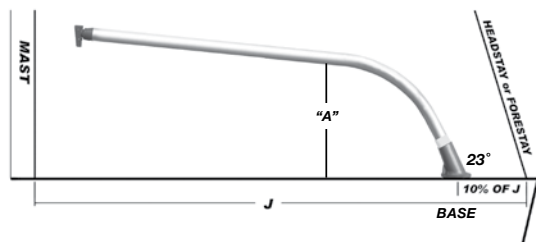

HOYT JIB BOOM MODELS

Part#	Model No.	Tube Dia	Weight	Knuckle Length	Boom Tube Length	Suggested Maximum J	Yacht LOA	Base Dia	"A"
313101	250	2.5" OD	16lbs	2.25"	6'	10'	25' - 29'	7"	14"
313102	300	3.0" OD	24lbs	2.50"	11'	13'	30' - 35'	7-3/4"	17"
313103	350	3.5" OD	37lbs	2.75"	13'	17'	35" - 42'	8-3/4"	21"
313155	Universal Wedge (SOLD IN PAIRS)								

ROLL-X FLOPPER STOPPER

Removable Anchorage Stabilizer

The Roll-X Flopper Stopper limits the rocking and rolling of a rough anchorage. Exclusive baffle design provides superior stability.

- Can be Quickly Deployed and Removed
- Stainless Steel and Aluminum Construction
- Professional Installation Recommended



NEW



Part #	Boat Length
305301	Roll-X Stabilizer
305302	Pole Kit for Boats to 40'
305303	Pole Kit for Boats to 55'
305304	NEW Roll-X Storage Bag

MULTIHULL SPRIT KIT



Articulating Sprit Adds Downwind Sail Functionality to Multihulls. This sprit kit can be fitted to most multihulls to allow for use of reaching spinnakers and drifter sails.

- Increases Downwind Performance
- Can be used with Continuous Line Furling Systems
- Professional Installation Recommended

Part #	Boat Length
305003	25'-23'
305004	36' to 42'
305005	43' to 50'

MARINE LABELS

These popular label sets are great for any racer or cruiser. Add safety and organization to your above and below deck systems. Remember, not everyone on board knows your boat as well as you do. All labels are self-adhesive, vinyl plastic, waterproof and won't fade. Perfect for flat, round or irregular surfaces of metal, fiberglass or paint.

SAILBOAT LABELS

10014

100016

100010

100011

100013

100024

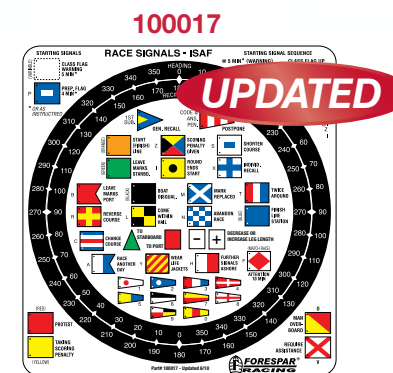

Part No.	Model
100010	Track numbers
100011	One 0"-10" scale
100013	Spar labels
100014	Cleat and winch labels
100016	Control lines
100017	Racing flag signals
100024	Stoppers Labels

Helps Prevent Crew Snafus!



MARELON® WINCH

Molded of Marelon® for exceptional strength, this lightweight winch will easily handle up to 200 square feet of sail. This little winch is ideal for use on the modern trailer-sailor or the small racer. On larger boats it is great for out-hauls and other control lines with relatively low loads. Weighing in at less than one pound you will find many uses for this tough little winch. Use four 1/4" fasteners (not included).

- Product Of Ultra Light Composite Technology
- For Up To 200 Sq. Ft. Of Sail
- Only Weighs .86 Lbs.
- All Marelon® Construction
- No Corrosion
- Accepts Standard Star Drive Winch Handle
- 8:1 Power Ratio When Used With A 10" Handle
- 6:1 Power Ratio When Used With An 8" Handle

DIMENSIONS

Height: 3-3/8", Base diameter: 3-5/8"
Top diameter: 3-1/4", Drum diameter: 2-7/16"
Four 1/4" fastener holes in 1-7/8" square pattern



Part No.	Description	Model No.
960003	Marelon® Winch	MW-6



NEW

STEERING CONTROL ARM

Our new Steering Control Arm allows you make minor course adjustments without being directly in touch with your wheel. The tiller like system can be quickly attached or removed with push of a button.

- Greater Forward Visibility
- Easy Course Corrections Autopilot's Can't Perform
- Great for Relaxation While Maintaining Control



Part No.	Description
104018	Steering Control Arm

RAILFAST® HARDWARE

ATTACH ACCESSORIES TO YOUR SIDE RAILS TO SAVE VALUABLE DECK SPACE!

Railfast Hardware allows you attach a wide variety of accessories to your round side rails. Great for sail or powerboats, your imagination is the only limit to how you can use Railfast Attachments. Fish cleaning boards, stoves, flag poles, GPS receivers, fenders, solar panels can now all be securely mounted to your rail without drilling.

The patented Railfast® mounting system offers an attractive, yet functional method for mounting gear to a boat railing. All Railfast® system parts are corrosion-proof nylon or stainless steel. An assembly tool and all necessary hardware included.

FOR ONLINE HOW-TO INSTALLATION VIDEOS AND OTHER RAILFAST ACCESSORIES GO TO: www.forespar.com/railfast



DO IT YOURSELF!

The number of uses for the Railfast® mount is as unlimited as your own imagination! Assemblies are available that make it easy for you to create your own device to mount almost anything to your railing.

MOUNTING BOSS - RAILFAST DIY BRACKET

The Railfast® mounting boss consists of the rail clamp assembly and a cover piece with a flat surface, all secured by a single bolt. Mount fender baskets, running lights, solar panels, barbecues, etc.



Part No.	Model No.
156011	300-1" Rail
156031	300-1-1/4" Rail

MOUNTING FLANGE - DIY BRACKET

Railfast® mounting flange-350 provides a flat, 4-hole mounting surface that can be adapted to a variety of uses. Mount cutting tables, outboard brackets etc. The 350 is also used with the Mini-Galley bracket.



Part No.	Model No.
156012	350-1" Rail
156032	350-1-1/4" Rail

FLAG POLE SOCKET - DIY BRACKET

Railfast® assembly and flag pole holder make installing flag poles a breeze. The holder can mount at any angle on a horizontal bow or stern rail and will accommodate flag poles with 1" base diameters. A set screw holds flag pole in place.



Part No.	Model No.
156006	324-FPH-1" Rail
156026	324-FPH-1-1/4" Rail

RAILFAST® ANTENNA MOUNTS

Railfast® is a great way to install your antennas. It mounts quickly to 7/8", 1" or 1-1/4" railings, horizontally, vertically, or at any angle, providing a professional and secure mounting for standard VHF, CB, and Loran antennas up to 8' in length. A special internal feed-through channel accommodates Loran cable that is routed directly out the bottom of the coupler.

NYLON ANTENNA MOUNT

Ideal for permanent fixed installation of antennas.

Part No.	Model No.
156009	311-N-1" Rail
156029	311-N-1-1/4" Rail



NYLON ANTENNA MOUNT WITH HANDLE

Molded with a fiberglass additive for superior strength. Laydown handle for passing under bridges storage or trailering.

Part No.	Model No.
156008	311-NLH-1" Rail
156028	311-NLH-1-1/4" Rail



UTILITY HOLDER

The Railfast® ring mounting bracket has a variety of uses including life rings, power cables, line or other accessories. Use in pairs to hold larger objects



Part No.	Model No.
156000	300-R-1" Rail
156020	300-R-1-1/4" Rail



HORSESHOE HOLDER

The Railfast® horseshoe mounting bracket is a must for any sailboat. Electro-polished stainless steel it is bent precisely to hold a standard horseshoe buoy securely without the need of a retaining strap.



Part No.	Model No.
156001	300-H-1" Rail
156021	300-H-1-1/4" Rail

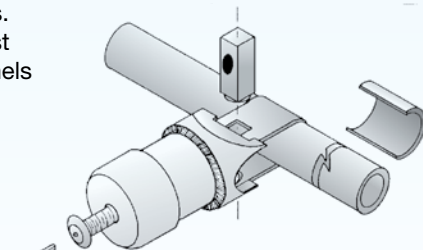

NO HOLES TO DRILL!!

This exploded diagram shows the components and demonstrates the ingenious simplicity of the system. It installs in minutes on any 7/8", 1" or 1-1/4" rail and requires no drilling.

Now Available For 1" or 1-1/4" Railings

HOT SPOT MINI-GALLEY®

FULLY GIMBALED & COMPACT PORTABLE STOVE

The Mini-Galley® Hot-Spot is a compact, versatile, fully gimbaled marine stove. This modern, attractive unit includes a low profile mounting bracket which allows the entire stove to be easily detached and stowed when not in use. It features an all stainless steel gimbaled "basket" with springs that secure the cooking pot. The Mini-Galley® Hot-Spot allows cooking under adverse weather conditions in the cockpit or below. The burner can be turned off and on instantly with no preheating or priming necessary. A disposable propane cartridge gives up to 8 hours of hot, clean heat. A simple valve permits any flame intensity. Designed to accept U.S. Department of Transportation approved self-sealing propane bottles.

- Makes Coffee in as Little as 5 Minutes
- Quickly Heats Canned, Frozen or Freeze Dried Foods
- Heats and Boils Liquid for Any Use
- Works as a Limited Use Heat Source Below Deck

SPECIAL FEATURES:

- Fully Gimbaled Stainless Steel Basket Cradles Pots Securely
- Extra Hot 5000 BTU Adjustable Flame Cooks or Boils Quickly
- Up to 8 Hours of Burn Time from One Tank
- Versatile Below Deck or On The Rail Use
- Great on Any Boat - Power or Sail

DIMENSIONS

Diameter: 8" • Height: 7" (Without fuel canister)
Weight: 1.5 lbs. (Including mounting bracket)

Propane Tank Not Included

INCLUDES: Pot, Gimbaled Cooking Burner, Tank Base

* Tank Base #150008 for use ONLY on shore on a non-moving surface

* Forespar® does not sell the D.O.T. approved propane canisters. They are available from your marine hardware dealer, camping supplies or major department stores in the U.S. and Canada. For European or other cartridges sold outside of the United States, an adapter may be needed for the various threaded canister tops sold outside of North America. These adapters should be secured prior to any long distance voyages outside the U.S. and may vary from country to country. Forespar® has designed this unit for use with U.S./D.O.T. propane cartridges and cannot be responsible for their availability outside the U.S.



MINI-GALLEY ACCESSORIES:



Part #150007
Quick-Mount Marelon Bracket
(Shown with Optional RailFast® Mounting Attachment)



Part #150018
Multi-Use Coffee & Cook Pot

Part No.	Model No.
150000	HOT-SPOT MINI-GALLEY®
156012 156032	RailFast 350 Mounting Flange (opposite page)
150007	Mounting Bracket Only

ADJUSTABLE TABLE PEDESTALS

The Forespar® Table Pedestal System features the choice of gas charged, non-gas high/low and fixed length table pedestals and incorporates bases molded from our exclusive light weight and corrosion resistant Marelon®.

The bases are 9-3/4" diameter. The standard gas and non-gas high/low systems are 13" collapsed measured from the flange of each base with a 5" bury below the sole. The lower base is epoxied to the tube. Maximum height is 26". The base can be moved up or down upon request however, the overall length of the tubes stays constant. For example if you request a 2" bury, you will have a 16" collapsed height(see diagram). The upper mounting flange is a tapered "slip fit" to the tube. This may also be epoxied for added stability and strength. All tube is sold by the inch and includes any/all tapers required.



Standard Dimensions

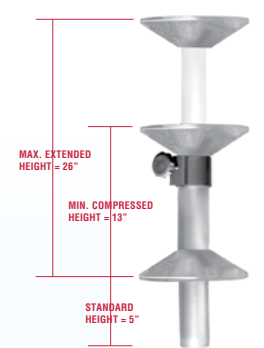

Part No.	Model	Part No.	Model
161001	Gas spring set-silver coated surface bases	164008	2-3/8"(60mm) "teak-look" surface base only
161004	Gas spring set-"teak-look" surface bases	164034	3"(76mm) plug/cap/cover
161003	Non-gas high/low set-silver coated surface bases	164035	2-3/8"(60mm) plug/cap/cover
161006	Non-gas high/low set-"teak-look" surface bases	170001	2-3/8"(60mm) fluted aluminum tube*
164021	3"(76mm) silver coated surface base only	170002	3"(76mm) fluted aluminum tube*
164009	3"(76mm) "teak-look" surface base only	170003	2-3/8"(60mm) brown anodized fluted aluminum tube
164011	2-3/8"(60mm) silver coated surface base only	170004	3"(76mm) brown anodized fluted aluminum tube
164008	2-3/8"(60mm) "teak-look" surface base only		

MINI GALLEY, TABLE PEDESTALS

NOVA DAVIT™

The Nova Davit™ system represents the “State of the Art” for styling and function. Versatile mounting designs assure a perfect fit with an offshore strength standard. Like all Nova products, a very high standard of finish will make the right statement about your boat. The neat folding feature stows the davit system flush with your boat’s stern. The maximum safe working load is 350 lbs. per pair (175 lbs. per arm).



350 lbs. Safe Working Load Per Pair



Fits Rails from 23” to 32” High

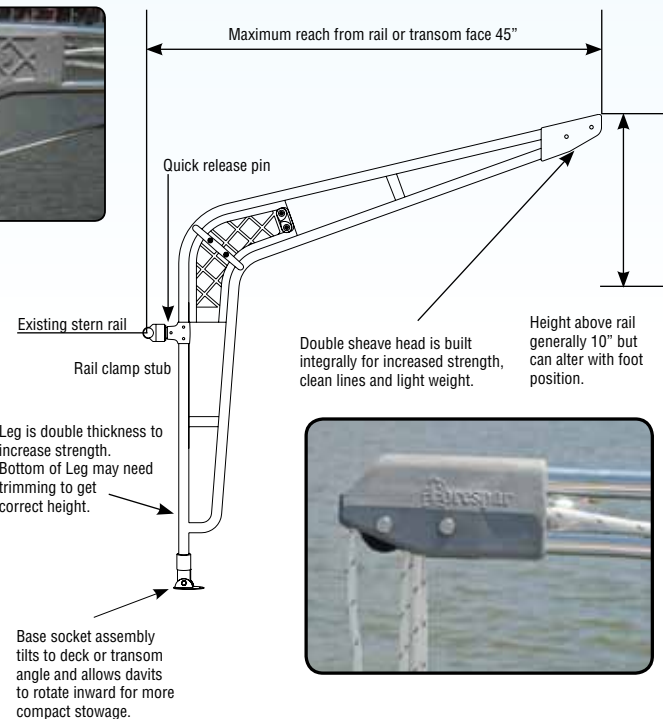

Light Weight, Strong 304 Stainless Steel

Nova Davit™ Conveniently folds inwards to maintain boat slip length or remove them completely for stowage or racing.

Part No.	Model No.
153302	Nova Davit™
153447	Optional 1-1/4 Rail Mount Kit

NOVA LIFT™

Our Nova products combine elegant styling with superb strength and function. The Patented Nova Lifts use internally led purchase to keep the lifting arm centered over the load. Other brands swing left and right without control. Another valuable feature is the internal lead to your cockpit winch where you have loads of lifting power to make the job easy! No external block & tackle.

Nova Lift™ comes with a stainless steel lower mounting tube that will accommodate 30” height rails. Vessels with rails higher than 30” will require the use of a deck pad (not included) to raise the installation to the proper height.

The Nova Lift™ with winch is ideal for trawlers and motor yachts where sailboat winches are not available.

Part No.	Description
153311	Nova Lift™
153312	Nova Lift™ With Winch
153308	Outboard Motor Sling
153387	1-1/4” Rail Adaptor
153303	Plastic Outboard Motor Mount - 1” Rail
153318	2-5” Optional Stand Off Bracket

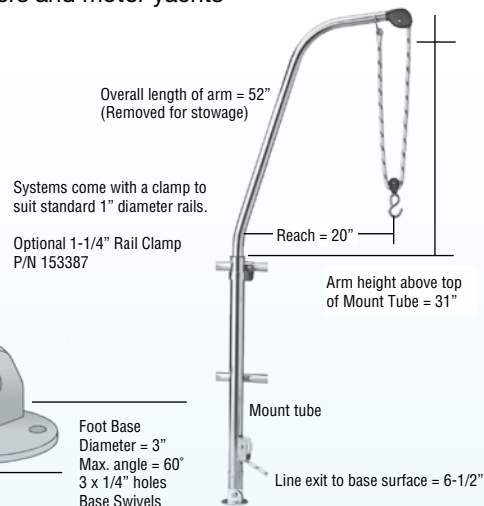

Nova Lift™



Nova Lift™ With Winch

220 lbs. Maximum Load



Stand Off Bracket

MOTOR MATE™

Features heavy duty anodized aluminum, powder coated white for added corrosion resistance. The unit stores in its own 31” X 6” bag. Comes with tackle and will lift anything from the dinghy to the cockpit (or vice-versa) up to 100 lbs. Great for the dinghy motor, but also good for SCUBA tanks, ice, duffel bags, groceries, etc.

The Motor Mate™ uses a Railfast® mounted ring on the rail and a “toe” on the cockpit coaming directly under the rail.

- Light-Weight, Portable, Compact
- Ideal for Lifting Outboard Motors, Sea Bags, SCUBA Gear
- Lifting Capacity: 100 lbs. (the weight, approximately, of a 15 hp. outboard)
- Works Great for Both Power Boats & Sailboats

**Boom Length: 20”
Assembled Height: 54”
Weight: 12 lbs.**

Part No.	Description
153100	Motor Mate™
153104	Base Mount *
153105	Rail Mount *
153130	Cam Cleat Bracket
153109	Vinyl Bag *

*Included with MOTOR MATE™

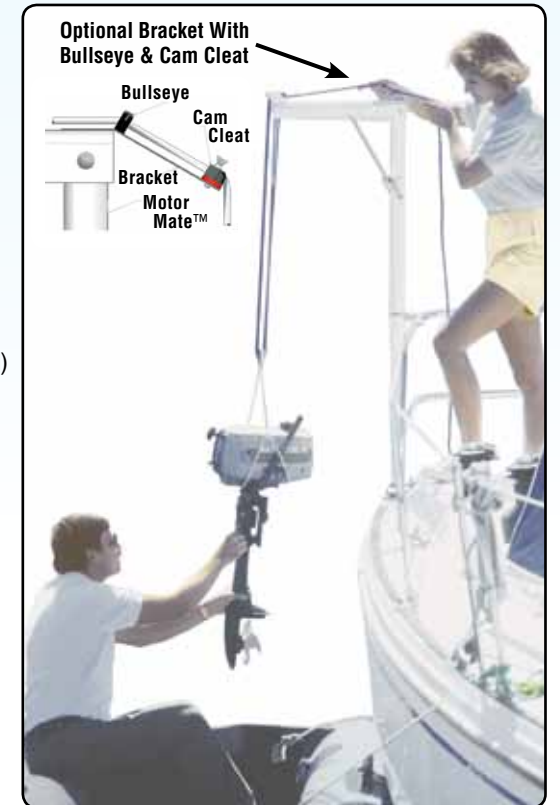

CARGO MATE™

This heavy duty white powder coated aluminum heavy lifter mounts and dismounts with ease. CargoMate™ stows neatly in a quality bag, and complete tackle is included. Winch drum capacity provides for 13 vertical feet of lift.

With greater lift capacity, the unit should be thru-deck mounted on sailboats and coaming or transom/swim step mounted on power boats. Deck flange and universal base mount provided as standard. 33” column extensions available.

- The Big Brother to Motor Mate™
- Lifting capacity: 250 lbs.
- Integral ratchet type winch provides 15 to 1 lift ratio.
- For both Power & Sail.

**Boom Length: 34”
Assembled Height: 54”+
Weight: 32 lbs.**

Part No.	Description
153200	Cargo Mate™
153207	33” Extension Tube
153209	Storage Bag*
153230	Deck Mounting Flange*
153233	Power Boat Mounting Ring

*Included with CARGO MATE™



LEISURE FURL IN-BOOM FURLING

THE WORLDWIDE LEADER FOR IN-BOOM MAINSAIL FURLING AND HANDLING SYSTEMS

Leisure Furl booms are custom made to order in the United States. Forespar is backed with 30+ years of experience and a reputation for delivering the highest quality spars and booms for the blue water cruisers and everyday sailors alike.

Why Should I Choose Leisure Furl?

Safety - With all lines leading aft, Leisure Furl gives you the ability to reef and control the main from the safety of the cockpit. Leisure Furl eliminates the need for complicated lazy jacks or sending crew forward in heavy weather.

Ease of Use - Hoisting, furling or reefing is a one-person operation.

Reefing - Allows infinite reefing positions on all points of sail.

Appearance - The sail furls neatly and compactly into the boom, protecting the sail from harmful ultraviolet rays. Each boom is elegantly tapered for good looks and weight-savings.

CUSTOM MADE IN THE USA

Forespar Leisure Furl booms are custom made to order in the United States. Forespar is backed with 30+ years of experience and a reputation for delivering the highest quality spars and booms for blue water racers and leisure sailors.

SAIL-SHAPING ADVANTAGES OF LEISURE FURL

1 Leisure Furl's built-in controls ensure that sail shape is maximized when at full hoist or furled. They allow for efficient and uncompromising performance from all points of sail and enable infinite reefing positions.

2 Leisure Furl allows mainsail control at any point of hoist. A perfect sail shape is ensured by the built-in sail controls.

3 Leisure Furl offers complete control over foot shape and luff tension, without the need of a cunningham or outhaul. Full-length battens give shape and power to even an old sail.

4 Leisure Furl enables a full roach in most cases, as opposed to the hollow cut leeches of most in-mast systems.

Able To Accommodate Large Roach Mainsails As Used On Multihulls.



LEISURE FURL OFFSHORE SYSTEM

THE SMART CHOICE FOR BOATS 33' - 70'

Over 4,000 systems in use, making ocean passages all over the world in all sea conditions. After 15 years of development, Leisure Furl is a highly efficient, safe and simple method of reefing and controlling the mainsail. The Forespar Leisure Furl is developed, marketed and built by a spar builder of the highest reputation. We have been building spars in the U.S. for over 40 years.



Limited 5-Year Warranty

Leisure Furl™ FEATURES

- Each boom is custom engineered and fabricated for your boat
- Each boom is elegantly tapered for attractiveness and weight savings
- Easily fitted to an existing mast without the need to unstep your mast
- Spar grade 6005 T5 heat treated aluminum alloy extrusions for superior strength
- All gooseneck fittings are high-strength 17-4 investment cast stainless steel

When I ordered my new Catalina 42 this spring, I investigated boom-furling systems. I quickly learned that Leisure Furl is the leader. I have not been disappointed in my choice. Our Leisure Furl boom reefs and furls beautifully and the tapered profile is very good looking.

Sincerely,
Cal Marks (Marina del Rey)

Leisure Furl™ Options Include

- Aluminum Construction
- Carbon Fiber Construction
- Hydraulic Drive Option
- Anodized or painted in any Awlgrip® Color
- Electric Operation



Built-in Sail Cover

Each Leisure Furl™ boom comes standard with a built-in sail cover for convenience and ease of handling. The Sunbrella® sail cover protects the sail from the harmful elements.



Manual Override

Each offshore system has a built-in manual backup in case of halyard or furling line failure. Winch handle control is easily accomplished at the mast. The internal ratchet allows the system to be locked in place for long passages.



Load Bearing Points

Leisure Furl's unique design offers 3 separate load bearing points. The mainsail and boom loads are distributed primarily to the mandrel and drive shaft bearing while the mainsheet and vang loads are carried by the gooseneck fitting.



SAILKOTE
RECOMMENDED
FOR LUFF TRACK
AND BOLT ROPE
APPLICATIONS

Leisure Furl™ CONVENIENCE

Remove Sail Cover & Ties and Stow Away
Lower and Flake the Sail
Tie Sail and Replace the Sail Cover

Conventional Boom

15 minutes
10 minutes
15 minutes

Leisure Furl™

30 seconds
90 seconds
30 seconds

LEISURE FURL COASTAL SYSTEM

HEAVY WEATHER IN-BOOM FURLING & REEFING FOR SAILBOATS 26'-33'

The Leisure Furl Coastal System offer smaller boats (26' - 33') the safety and convenience of In-Boom mainsail handling in a system specifically designed and sized to boats of this size.

Derived from our Leisure Furl family of big boat offshore furling and reefing booms, our Coastal model boom incorporates exceptional drive and universal technology with a minimum of moving parts. This powerful boom system incorporates an end boom drive system with a minimum of moving parts which is effective for smaller boat applications. Our Offshore, through the mast, drive system is used on more powerful mainsails on boats from 35 ft – 85 ft.

The aft drive mandrel uses fiber impregnated composite bearings similar to those used in the construction of big boat high load blocks. The forward universal allows complete freedom of rotation under the highest loads.

- Five Year Limited Warranty
- Easily Fitted To An Existing Mast
- Custom Engineered For Your Boat
- Controllable Sail Shape
- Tapered for Attractiveness And Weight Savings



Enjoy the Same Safety of In-Cockpit Mainsail Reefing & Handling Used by Larger Boats

Maximum Coastal System luff length (P) is 40' and maximum foot length (E) is 14"

Our Leisure Furl Coastal, in boom, mainsail-furling system has been installed on our Catalina 30 for approximately six months now. We could not be more pleased.

The system has worked flawlessly from the day it was installed. It has given us the confidence to sail short-handed in conditions where we would have hesitated with a conventional reefing system. My wife especially likes not having to deal with the sail ties and the dirty mainsail cover.

The design, engineering and production quality of the Leisure Furl Coastal system is better than other systems that we looked at.

Sincerely,
William E. Garrett, Jr., CPM
President Inter-Pacific Asset Management
Westminster, California



LEISURE FURL™ COASTAL SYSTEMS FEATURE



Catalina 30

Hand Crafted Boom

Each boom is custom made at our plant in Southern California by professional riggers. The boom is tapered for refined styling and weight savings.



Morris 36

Luff System

Leisure Furl™ uses high modulus PVC luff track.



Reinforced Entry

Each Forespar Leisure Furl has an additional stainless steel frame at the front of the boom. This reinforces the already tough aluminum section.



Built-in Sail Cover

Each Leisure Furl™ boom comes standard with a built-in sail cover for convenience and ease of handling. The Sunbrella® cover protects the sail.

CUSTOM MASTS AND BOOMS

CUSTOM OR REPLACEMENT BOOMS AND SPARS FOR ALMOST ANY BOAT



OFFSHORE • COASTAL • RACING

Forespar® builds superior quality aluminum and carbon fiber spar systems for builders of the finest yachts, worldwide. Our sales department establishes the customer relationship, develops the order and serves as the conduit for information during the project.

Engineering develops the design data using CAD systems and several proprietary computer programs to optimize the spar system. The manufacturing team then fabricates the spars in conjunction with a multilevel quality control system. The spar systems are finished using Awlgrip marine coatings, then assembled using the high quality components that our customers demand.

After passing the final inspection, the spars are packaged to be shipped anywhere in the world.

The result of the process is superior reliability and function for the offshore or casual sailor.

ALUMINUM OR CARBON CONSTRUCTION



Hylas 70
Mast & Leisure
Furl Boom



OVER 40 YEARS
OF MAST AND BOOM
BUILDING EXPERIENCE

Nantucket Splinter Custom
Carbon Boom



Schock 40
Carbon Mast



CUSTOM MASTS AND BOOMS

REFRESH™ DEODORIZERS

ReFresh™ is Forespar's new family of all natural, environmentally safe cleaners and deodorizers that are specially formulated to work on tough marine based odors. Guaranteed to work, each of these modern green products is specifically formulated using naturally biodegradable ingredients to create effective, non-toxic alternatives to traditional chemical based cleaners. The new ReFresh™ family includes three specially formulated, non-diluted marine strength products for your most frequent needs.

- Non-Toxic and Biodegradable
- Naturally Attacks Odor Source
- Not A Cover-Up Fragrance

ReFresh™ Cleanup Concentrate

A general-purpose marine grade deodorizer for cleanup or wash-down that permanently eliminates odors by naturally attacking the source. Used with proper cleaning, it quickly removes common boat odors such as bilge, fish, head and vomit, and can be used on almost any surface including fabric. It also works on gas and oil. Non-staining and water based. Available in 16 ounce bottles that can make up to 10 quarts of deodorizer.

Part No	Description
770062	16 oz ReFresh Cleanup Concentrate



Naturally Green
Guaranteed to Work



ReFresh™ Atomizer Spray Deodorizer

A general-purpose spray deodorizer that quickly eliminates tough marine odors from the air and lightly soiled surfaces. Not a cover-up fragrance, its non-staining water based formula can be used on most surfaces, including fabric, and lasts up to three months by naturally eliminating the source of the odor. Available in an 8 ounce pump spray bottle.

Part No	Description
770064	8 oz ReFresh Atomizer Spray Deodorizer

ReFresh™ Head & Tank Deodorizer

A non-toxic and biodegradable marine head and waste tank treatment that naturally eliminates odor sources for up to 4 months. Not a cover-up fragrance, it starts working immediately and is equally effective on liquids and solids. Safe on either bronze or Marelon composite type plumbing systems. One ounce treats a 20-gallon tank. Available in 16 ounce bottles, it can be directly poured into the system by flushing.

Part No	Description
770063	16 oz ReFresh Head & Tank Deodorizer



NEW



MARINE GRADE COMPOSITE PLUMBING
U.L. APPROVED & ISO CERTIFIED
ABOVE AND BELOW WATERLINE



MARELON®

COMPOSITE PLUMBING PARTS

MARELON® PLUMBING SYSTEMS

COMPOSITE, NON-CORROSIVE MARINE PLUMBING SYSTEM

Marelon® is the perfect material for marine plumbing systems. It's non-corrosive proprietary formulation of polymer composite compounds use a resins and additives to produce a superior marine-grade product that will not deteriorate like traditional bronze marine plumbing parts.

- For Use Above And Below Waterline
- Precision Molded Plumbing Systems
- Complete Freedom From Corrosion
- U.L. Approved & ISO Certified
- A.B.Y.C. Compliant
- Forespar® "93" series of valves and thru-hull fittings meet all design criteria and exceed all mechanical property requirements specified by the International Standards Organization

(ISO150/188) "Small Craft Seacocks and Thru-hull Fittings-Part 2: Non-Metallic"



MARELON COMPARISON CHART

	U.V. Degradation	Corrosion Resistance	Abrasion Resistance	Tensil Strength**	Flexural Modulus***	ABYC* Req.	U.L.* Req.	Total Score
MARELON	10	10	10	10 (17,500psi)	10 (1,300,000mPa)	10	10	70
NYLON	6	10	5	10 (12,000psi)	4 (410,000mPa)	0	0	35
ACETAL	5	10	6	5 (10,000psi)	5 (450,000mPa)	0	0	31
PVC	3	10	2	3 (5,015psi)	3 (434,000mPa)	0	0	21
POLYPROPYLENE8		10	7	2 (4,150psi)	2 (75,000mPa)	10	10	29
BRONZE	10	4	10	10 (35,000psi)	10 (15,000,000mPa)	10	10	64
BRASS	10	0	10	10 (45,000psi)	10 (11,000.00mPa)	0	0	40

* Minimum physical properties required for approval are: Tensil strength 10,900psi 75mPa, Flexural modulus 500,000psi 3480mPa

** Value by test to ASTM D638 (American Society of Testing & Materials) Marelon is a registered trademark of Forespar Products Corp.

*** Value by test to ASTM D790 (American Society of Testing & Materials)

THE MODERN SOLUTION FOR MARINE PLUMBING

BENEFITS TO BUILDERS

- Lightweight, yet extremely strong injection-molded parts
- Complete freedom from any corrosion
- Complete freedom from electrolysis or reaction to any metals
- Outstanding operating temperature range (-22° to +176° F.)
- Uses in deck hardware (cleats, chocks) and marine plumbing
- Outstanding U.V. resistance and color fix
- Marelon® valves offer an unprecedented variety of designs
- Long term reliability



BENEFITS TO THE BOAT OWNER

- No bonding (electrical) required
- Configurations to fit tight machinery spaces
- Minimal maintenance requirements
- Ease of installation with standard tools
- Accepts adhesives and coatings (bottom paints) easily
- Can be used on aluminum, steel, wood or FRP hull forms
- Excellent chemical resistance to harsh bilge cleaners
- Can be used with or on any metal fittings
- Long term reliability

A.B.Y.C H-27, Seacocks, Thru-Hull Connections And Drain Plugs And ISO/DIS 9093-2 STANDARD, Small Craft - Seacocks & Thru-Hull Fittings - Non-Metallic

THE FORESPAR MARELON BALL VALVES AND THRU-HULL FITTINGS MEET AND EXCEED THE ABYC H-27 AND ISO 9093-2 STANDARDS AS PRESENTLY WRITTEN IN ALL RESPECTS.

As to Physical Property Requirements:

	ABYC Standard	ISO Standard	Marelon Properties
Tensile Strength:	75mPa 10,900 psi	60mPa 9,715psi	121mPa 17,500psi
Flexural Mod.:	3480mPa 505,000psi	2700mPa 391,500psi	4826mPa 700,000psi
Impact Strength:	None	9Kj/m	117j/m
As to Strength Test:	2224N 500lbs.	1500N 337lbs.	2224N 500lbs

MF 850 BALL VALVES

Forespar's MF 850 series of Ball Valves are precision molded in high strength Marelon®. Their great strength, light weight, and complete freedom from corrosion and electrolysis make them the ideal valve for controlling inlet and outlet water requirements above and below the waterline.

Our engineers opened and closed one of our 3/4"(19.05mm) valves 11,000 times, then submerged it in water with an air line pressurized to 40 p.s.i. connected to it. The result was an absolutely leak free condition with no evidence of wear on internal seals.

All valves sold throughout the U.S.A. have N.P.T. type threads. If specified, B.S.P. are available on valves sold outside of America.

The temperature range of Marelon® is: -40° F to +176° F or -40° C to +80° C

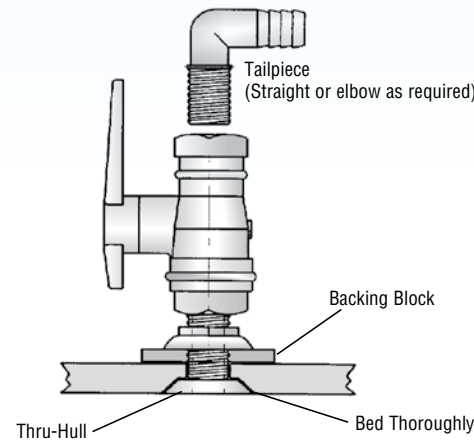

VALVE MAINTENANCE

All our valves are non-corrosive, but like any moving part in a marine environment, they require regular inspection and lubrication. Do not fail to actuate the handle and lubricate the seals on a regular schedule (water pump grease or even mineral oil will lubricate seals).



LIMITED WARRANTY

Forespar® accepts no responsibility for valve or thru-hull components which are improperly installed, tampered with or have inadequate access for service and maintenance.

Part No.	Model No.	Thread Size	Body Dia.	Body Length	Length w/Handle
905100	MF 850 1/2"	1/2"(12.7mm)	1-7/8"(47.62mm)	3"(76.2mm)	4"(101.6mm)
905101	MF 850 3/4"	3/4"(19.05mm)	1-7/8"(47.62mm)	3"(76.2mm)	4"(101.6mm)
905102	MF 850 1"	1"(25.4mm)	2-3/4"(69.85mm)	4-3/4"(120.65mm)	5-1/2"(139.7mm)
905103	MF 850 1"-1/4"	1-1/4"(31.75mm)	2-3/4"(69.85mm)	4-7/8"(123.82mm)	5-3/4"(146.05mm)
905104	MF 850 1"-1/2"	1-1/2"(38.1mm)	3-1/2"(88.9mm)	5"(127mm)	7-1/2"(190.5mm)
905105	MF 850 2"	2"(50.8mm)	4-1/4"(107.95mm)	5-7/8"(149.22mm)	8"(203.2mm)

SCOOP STRAINERS

These high-strength, high-speed, strainers are also made of non-corrosive Marelon®. Two piece construction allows for greater ease in installation. Available in 3/4"(19.05mm) and 1-1/4"(31.75mm) thread sizes.

NOTE:
Now Available in White Only

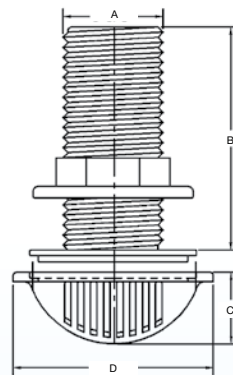

Part No.	Model No.	Thread Size	A	B	C	D
906059	MF 867 3/4	3/4"(19.05mm)	1-1/32"(26.18mm)	2-1/4"(57.15mm)	1"(25.4mm)	3-1/8"(79.37mm)
906060	MF 868 1-1/4	1-1/4"(31.75mm)	1-5/8"(41.27mm)	2-15/16"(74.42mm)	1"(25.4mm)	3-3/8"(85.72mm)
906061	MF 865 3/4	screen only			1"(25.4mm)	3-1/8"(79.37mm)
906062	MF 866 1-1/4	screen only			1"(25.4mm)	3-3/8"(85.72mm)

Screens only can be epoxied to the hull to eliminate additional holes in the gel-coat. Scoop screens can also be used over other thru-hulls (flush head styles are best) whenever a force feed is required.



FOR ONLINE TECH TIP ABOUT VALVE MAINTENANCE GO TO:

www.forespar.com/techtips

SMART VALVES OEM SALES ONLY (Original Equipment Manufacturer)

LIGHTED PANEL INDICATES VALVE POSITION



SMART VALVE™ Patent Pending

The Smart Valve™ provides the safety and assurance of a visual display panel showing which seacock is open or closed-without having to go below and pull up floorboards to make a visual inspection. Sensors, factory installed, on any new single port, Marelon Integrated Plumbing System flange mounted valve use state-of-the-art sensing technology to monitor the valve's handle position. Display panels use red and green LED lights to indicate which valve is open (green LED) or closed (red LED). Simple two wire lead from each valve makes installation easy. Power is supplied directly to the panel only. Panels are offered in 4, 8 and 12 valve combinations with valve use names (i.e. "Head Intake") engraved on each panel.

Please use Smart Valve ROV™ order form for ordering instructions and to note valve names for engraved panel. - www.forespar.com/orderforms



Part No.	Model
930150	4 valve/panel
930151	8 valve/panel
930152	12 valve/panel

Please specify 12v or 24v systems
For OEM valve installations only

REMOTE OPERATED SMART ROV™ VALVES

SWITCH OPERATED VALVES OPEN AND CLOSE ON-DEMAND

With the success of the Smart Valve™, the next logical step was to make valves remote controlled. Forespar® can now offer the Smart Valve ROV™ (Remote Operated Valves) to boat builders wishing to offer their customers the added convenience of operating their seacocks from the helm (or wherever you wish to mount the control panel) all without the need to go below, get on your knees and reach into the bilge to open or close the valve(s).

Powerful sealed motors open or close the valve(s) with a push of a button. Any valve suitable for Smart Valve™ sensors can be made (at the factory) to be remote operated. Four wires (two for the sensors, two for the motor) are lead to the Smart Valve ROV™ panel that is custom engraved and has the red and green LED indicator lights. As with the Smart Valve™, power is supplied directly to the control panel only. ROV panels come in 4 & 8 valve sizes only. Single switch independent ROV valve systems also available. Contact Forespar for further information.

Forespar® can also supply Smart Valve ROV™ Systems that can be used with the new, state-of-the-art power distribution & systems integration "CAN-BUS" type systems.

OPTIONAL ELECTRONIC PANEL

With this optional electronic relay board you can control up to four Smart Valves. Wire your engine starter switch to this board so the engine will not start until the valve is opened, or connect the macerator pump to make sure the intake seacock is ready.

Compatible manually, with the Smart Valve™ or Smart Valve ROV™. Simple "plug and play" installation via using phone cord style jacks behind the electrical panel, out of view. All Smart Valve™ and Smart Valve ROV™ Systems are compatible with the new "CAN-BUS" power distribution systems allowing even more "Systems Integration" and features to the OEM boat builder.

Part No.	Model
930153	Device Enable/Disable Feature

Please specify 12v or 24v systems



Part No.	Model
930145	1/2" - 3/4" valves
930146	1" - 1-1/4" valves
930147	1-1/2" - 2" valves

Please specify 12v or 24v systems
For OEM valve installations only



Original Equipment Manufacture - OEM SALES ONLY

FLANGE MOUNTING SEACOCKS

A WORD ON THREAD FORMS

The American standard for tapered or parallel threads have a thread flank angle of 60°. The British standard for tapered or parallel threads have a thread flank angle of 55°. Identification can also be made by inspecting the root and crest of the threads. The truncation of the root and crest of American standard threads are flat. The truncation of the root and crest of British standard threads are round.

Forespar® offers a wide selection of extremely strong and reliable marine grade plumbing fittings. You will find each product to be carefully designed for ease of installation, versatility in application as well as unsurpassed durability.

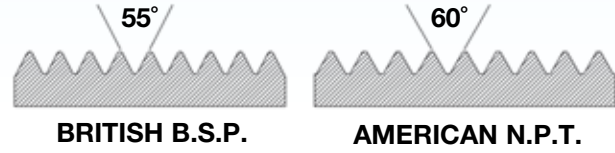

MF 849

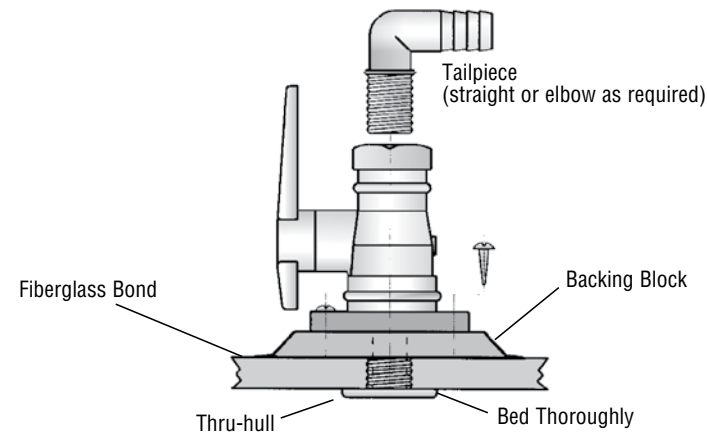

Part No.	Model No.	Thread Size	Height	Height w/Handle	Base
904009	MF 849 1/2	1/2"(12.7mm)	3"(76.2mm)	4"(101.6mm)	3"(76.2mm)
904010	MF 849 3/4	3/4"(19.05mm)	3"(76.2mm)	4"(101.6mm)	3"(76.2mm)
904011	MF 849 1-1/2	1-1/2"(38.1mm)	5"(127mm)	8"(203.2mm)	6"(152.4mm)

TYPICAL HEAD INSTALLATION

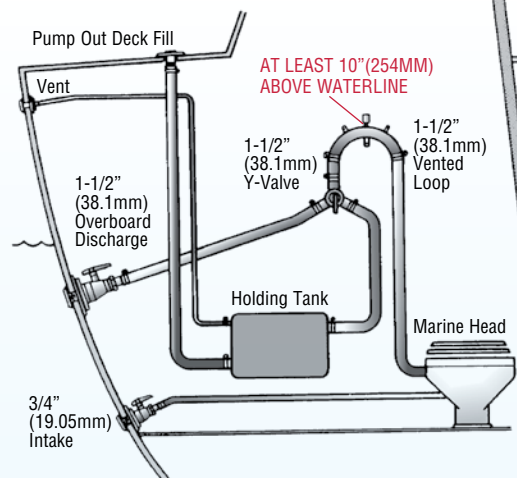

SINK DRAIN INSTALLATION

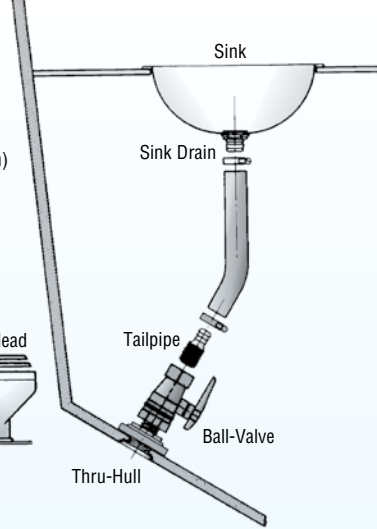

COCKPIT DRAIN INSTALLATION

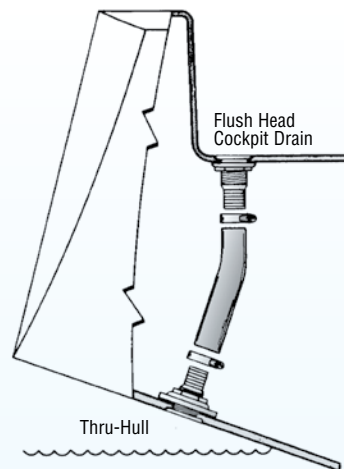

NOTE: IF A THRU-HULL IS TO BE INSTALLED LESS THAN 6"(152.4mm) ABOVE WATERLINE, A BALL-VALVE OR SEACOCK MUST ALSO BE USED.

THRU-HULL CONNECTORS

Forespar® series of Thru-Hull Connectors are precision molded in high strength Marelon®. Their great strength, light weight and complete freedom from corrosion and electrolysis make them the ideal Thru-Hull Connectors for use above or below the waterline. All Thru-Hull Connectors must be installed with proper bedding compound. We recommend a maximum torque setting of 20 lb/ft. for Series 250, Series 251 and Series 253 Thru-Hull Connectors.

THE 'S' NOTATION IN MODEL NUMBERS (EG. CF 250S 1/2), INDICATES A THRU-HULL THAT HAS BEEN FITTED WITH A SCREEN.

250 SERIES

FULL THREADED/FLUSH HEAD

Part No.	Model No.	Thread Size	Length
906000	CF 250 1/2	1/2"(12.7mm)	2"(50.8mm)
906001	CF 250S 1/2	1/2"(12.7mm)	2"(50.8mm)
906002	CF 250 3/4	3/4"(19.05mm)	2.25"(57.15mm)
906003	CF 250S 3/4	3/4"(19.05mm)	2.25"(57.15mm)
906004	CF 250 1	1"(25.4mm)	2.375"(60.32mm)
906005	CF 250S 1	1"(25.4mm)	2.375"(60.32mm)
906006	CF 250 1-1/4	1-1/4"(31.75mm)	3"(76.2mm)
906007	CF 250S 1-1/4	1-1/4"(31.75mm)	3"(76.2mm)
906008	CF 250 1-1/2	1-1/2"(38.1mm)	3"(76.2mm)
906009	CF 250S 1-1/2	1-1/2"(38.1mm)	3"(76.2mm)

'S' DENOTES SCREENED

251 SERIES

FULL THREADED MUSHROOM HEAD

Part No.	Model No.	Thread Size	Length
906010	CF 251 1/2	1/2"(12.7mm)	2"(50.8mm)
906011	CF 251S 1/2	1/2"(12.7mm)	2"(50.8mm)
906012	CF 251 3/4	3/4"(19.05mm)	2.25"(57.15mm)
906013	CF 251S 3/4	3/4"(19.05mm)	2.25"(57.15mm)
906014	CF 251 1	1"(25.4mm)	2.375"(60.32mm)
906015	CF 251S 1	1"(25.4mm)	2.375"(60.32mm)
906016	CF 251 1-1/4	1-1/4"(31.75mm)	3"(76.2mm)
906017	CF 251S 1-1/4	1-1/4"(31.75mm)	3"(76.2mm)
906018	CF 251 1-1/2	1-1/2"(38.1mm)	3"(76.2mm)
906019	CF 251S 1-1/2	1-1/2"(38.1mm)	3"(76.2mm)
906020	CF 251 2	2"(50.8mm)	3"(76.2mm)
906021	CF 251S 2	2"(50.8mm)	3"(76.2mm)

'S' DENOTES SCREENED

253 SERIES

HOSE TAILPIPE/MUSHROOM HEAD

Part No.	Model No.	Hose I.D.
906022	CF 253 1/2	1/2" - 5/8"(12.7 - 15.87mm)
906023	CF 253S 1/2	1/2" - 5/8"(12.7 - 15.87mm)
906024	CF 253 3/4	3/4"(19.05mm)
906025	CF 253S 3/4	3/4"(19.05mm)
906026	CF 253 1	1"(25.4mm)
906027	CF 253S 1	1"(25.4mm)
906070	CF253 1-1/8	1-1/8"(28.57mm)
906071	CF253S 1-1/8	1-1/8"(28.57mm)
906028	CF 253 1-1/4	1-1/4"(31.75mm)
906029	CF 253S 1-1/4	1-1/4"(31.75mm)
906030	CF 253 1-1/2	1-1/2"(38.1mm)
906031	CF 253S 1-1/2	1-1/2"(38.1mm)
906032	CF 253 2	2"(50.8mm)
906033	CF 253S 2	2"(50.8mm)

'S' DENOTES SCREENED

THRU-HULL MEASUREMENTS

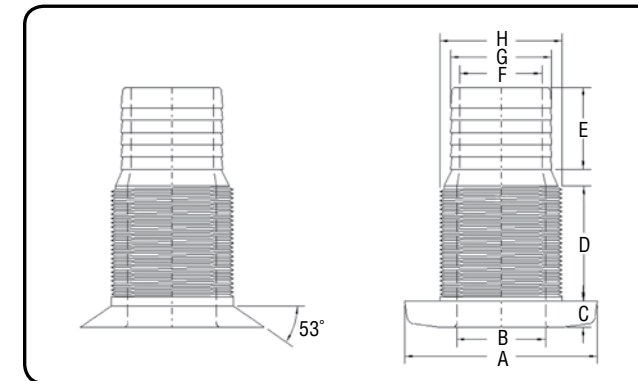

FLUSH HEAD DRAIN

Part No.	Model No.	Thread Size & Hose I.D.	Thread Length
906038	CF254 1-1/4	1-1/4"(31.75mm)	1 3/4"(44.45mm)
906036	CF 254 1-1/2	1-1/2"(38.1mm)	1 3/4"(44.45mm)
906037	CF 254S 1-1/2	1-1/2"(38.1mm)	1 3/4"(44.45mm)
906034	CF 254 2	2"(50.8mm)	1 3/8"(34.92mm)
906035	CF 254S 2	2"(50.8mm)	1 3/8"(34.92mm)
906039	CF 254 1-5/8	1-5/8"(41.27mm)	1 3/8"(34.92mm)

'S' DENOTES SCREENED

CORRESPONDING DIMENSION FROM ABOVE DRAWING SERIES

SERIES	A	B	C	D	E	F	G	H
250								
1/2"(12.7mm)	2.375(60.32mm)	.430(10.92mm)	.335(8.5mm)	2.000(50.8mm)	N/A	N/A	N/A	.810(20.57mm)
3/4"(19.05mm)	2.430(61.72mm)	.665(16.89mm)	.320(8.1mm)	2.250(57.15mm)	N/A	N/A	N/A	1.015(25.78mm)
1"(25.4mm)	2.835(72mm)	.875(22.22mm)	.320(8.1mm)	2.375(60.32mm)	N/A	N/A	N/A	1.285(32.63mm)
1-1/4"(31.75mm)	2.820(71.63mm)	1.115(28.32mm)	.325(8.25mm)	3.000(76.2mm)	N/A	N/A	N/A	1.635(41.52mm)
1-1/2"(38.1mm)	2.562(65.07mm)	1.380(35.05mm)	.320(8.1mm)	3.000(76.2mm)	N/A	N/A	N/A	1.850(46.99mm)
251								
1/2"(12.7mm)	1.500(38.1mm)	.448(11.37mm)	.256(6.5mm)	2.125(53.97mm)	N/A	N/A	N/A	.810(20.57mm)
3/4"(19.05mm)	2.084(52.93mm)	.690(17.52mm)	.335(8.5mm)	3.093(78.56mm)	N/A	N/A	N/A	1.028(26.11mm)
1"(25.4mm)	2.345(59.56mm)	.880(22.35mm)	.288(7.31mm)	2.400(60.96mm)	N/A	N/A	N/A	1.282(32.56mm)
1-1/4"(31.75mm)	2.650(67.31mm)	1.110(28.19mm)	.345(8.76mm)	2.950(74.93mm)	N/A	N/A	N/A	1.615(41.02mm)
1-1/2"(38.1mm)	2.940(74.67mm)	1.360(34.54mm)	.345(8.76mm)	2.950(74.93mm)	N/A	N/A	N/A	1.850(46.99mm)
253								
1/2"(12.7mm)	1.506(38.25mm)	.505(12.82mm)	.265(6.73mm)	1.490(37.84mm)	.975(24.76mm)	.439(11.15mm)	.657(16.68mm)	.812(20.62mm)
3/4"(19.05mm)	2.100(53.34mm)	.670(17.01mm)	.325(8.25mm)	1.677(42.59mm)	1.028(26.11mm)	.535(13.58mm)	.770(19.55mm)	1.015(25.78mm)
1"(25.4mm)	2.350(59.69mm)	.958(24.33mm)	.295(7.49mm)	1.695(43.05mm)	1.085(27.55mm)	.797(20.24mm)	1.015(25.78mm)	1.280(32.51mm)
1-1/4"(31.75mm)	2.675(67.94mm)	1.194(30.32mm)	.327(8.3mm)	1.818(46.17mm)	1.280(32.51mm)	1.021(25.93mm)	1.273(32.33mm)	1.615(41.02mm)
1-1/2"(38.1mm)	2.933(74.49mm)	1.350(34.29mm)	.345(8.76mm)	1.875(47.62mm)	1.280(32.51mm)	1.258(31.95mm)	1.530(38.86mm)	1.850(46.99mm)
2"(50.8mm)	3.511(89.17mm)	1.842(46.78mm)	.375(9.5mm)	1.875(47.62mm)	1.350(34.29mm)	1.610(40.89mm)	2.018(51.25mm)	2.320(58.92mm)
254								
1-1/4"(31.75mm)	2.805(71.24mm)	1.164(29.56mm)	.316(8.02mm)	1.500(38.1mm)	1.280(32.51mm)	.945(24mm)	1.260(32mm)	1.615(41.02mm)
1-1/2"(38.1mm)	2.805(71.24mm)	1.406(35.71mm)	.316(8.02mm)	1.500(38.1mm)	1.280(32.51mm)	1.115(28.32mm)	1.475(37.46mm)	1.850(46.99mm)
2"(50.8mm)	3.525(89.53mm)	1.672(42.46mm)	.325(8.25mm)	1.500(38.1mm)	1.300(33.02mm)	1.480(37.59mm)	2.018(51.25mm)	2.320(58.92mm)

TAILPIPES / HOSE CONNECTORS

Our Tailpipes are also made from high-strength glass-reinforced Marelon®. Perfect choice for joining hose lines to Forespar® Ball Valves and Seacocks.

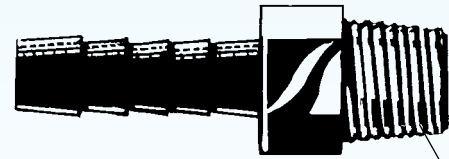
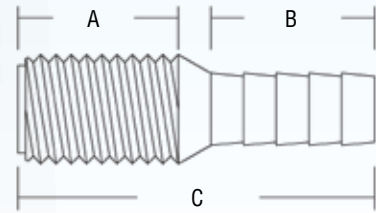

TAPERED PIPE THREADS

Part Tube No. I.D.	Model No.	Thread For Size
910146	HC 4x4	1/4"(6.35mm)
910147	HC 4x5	1/4"(6.35mm)
910148	HC 4x6	1/4"(6.35mm)
910149	HC 4x8	1/4"(6.35mm)
910150	HC 6x6	3/8"(9.52mm)
910154	HC 6x8	3/8"(9.52mm)
910156	HC 8x8	1/2"(12.7mm)
910157	HC 8x12	1/2"(12.7mm)
910158	HC 12x8	3/4"(19.05mm)
910159	HC 12x12	3/4"(19.05mm)
910160	HC 12x16	3/4"(19.05mm)
910168	HC 20x24	1-1/4"(31.75mm)

Part No.	Model No.	Thread Size	Tailpipe Dia.	A	B	C
905006	CF 252 1/2	1/2"(12.7mm)	5/8"(15.87mm)	1"(24.4mm)	1"(24.4mm)	2-1/4"(57.15mm)
905007	CF 252 3/4	3/4"(19.05mm)	3/4"(19.05mm)	1"(24.4mm)	1"(24.4mm)	2-3/8"(60.32mm)
905008	CF 252 1	1"(24.4mm)	1"(24.4mm)	1-1/2"(38.1mm)	1-1/2"(38.1mm)	2-7/8"(73.02mm)
905009	CF 252 1-1/4	1-1/4"(31.75mm)	1-1/4"(31.75mm)	1-5/8"(41.27mm)	1-1/4"(31.75mm)	3-1/4"(82.55mm)
905010	CF 252 1-1/2	1-1/2"(38.1mm)	1-7/16"(36.51mm)	1-7/16"(36.51mm)	1-1/8"(28.57mm)	2-5/8"(66.67mm)
905011	CF 252 2	2"(50.8mm)	2"(50.8mm)	1-11/16"(42.88mm)	1-1/4"(31.75mm)	3-1/4"(82.55mm)
905016	CF 252 1-1/8	1"(24.4mm)	1-1/8"(28.57mm)	1"(24.4mm)	1-1/16"(26.98mm)	2-7/8"(73.02mm)
905017	CF 252 1-1/2	1-1/2"(38.1mm)	1-1/4"(31.75mm)	1-7/16"(36.51mm)	1-1/4"(31.75mm)	2-5/8"(66.67mm)

ELBOWS

Molded from high-strength Marelon®. Dimension 'A' indicates pipe thread size.

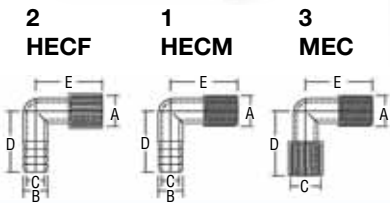

Part No.	Model No.	A	B	C	D	E
1 901000	HECM 8	1/2"(12.7mm)	5/8"(15.87mm)	7/16"(11.11mm)	2"(50.8mm)	1-1/2"(38.1mm)
901001	HECM 12	3/4"(19.05mm)	3/4"(19.05mm)	1/2"(12.7mm)	2-1/8"(53.97mm)	1-5/8"(41.27mm)
901002	HECM 16	1"(24.4mm)	1"(24.4mm)	5/8"(15.87mm)	2-1/2"(63.5mm)	1-7/8"(47.62mm)
901003	HECM 20	1-1/4"(31.75mm)	1-1/4"(31.75mm)	7/8"(22.22mm)	2-3/4"(69.85mm)	2-5/16"(58.72mm)
901004	HECM 24	1-1/2"(38.1mm)	1-1/2"(38.1mm)	1-1/16"(26.98mm)	3-1/4"(82.55mm)	2-3/4"(69.85mm)
901005	HECM 32	2"(50.8mm)	2"(50.8mm)	1-1/2"(38.1mm)	3-5/8"(92.07mm)	3-1/4"(95.25mm)
901052	HECM 24/20	1-1/2"(38.1mm)	1-1/4"(31.75mm)	7/8"(22.22mm)	2-3/4"(69.85mm)	2-3/4"(69.85mm)
901053	HECM 16/16.125	1"(24.4mm)	1-1/8"(28.57mm)	29/32"(22.86mm)	2-1/2"(63.5mm)	1-7/8"(47.62mm)
2 901006	HECF 8	1/2"(12.7mm)	5/8"(15.87mm)	7/16"(11.11mm)	2"(50.8mm)	1-5/8"(41.27mm)
901007	HECF 12	3/4"(19.05mm)	3/4"(19.05mm)	9/16"(14.28mm)	2-3/16"(55.56mm)	1-3/4"(44.45mm)
901008	HECF 16	1"(24.4mm)	1"(24.4mm)	5/8"(15.87mm)	2-1/2"(63.5mm)	1-7/8"(47.62mm)
901009	HECF 20	1-1/4"(31.75mm)	1-1/4"(31.75mm)	7/8"(22.22mm)	2-3/4"(69.85mm)	2-1/2"(63.5mm)
901010	HECF 24	1-1/2"(38.1mm)	1-1/2"(38.1mm)	1-1/8"(28.57mm)	3-1/8"(79.37mm)	2-3/4"(69.85mm)
901011	HECF 32	2"(50.8mm)	2"(50.8mm)	1-9/16"(39.68mm)	3-5/8"(92.07mm)	3-1/4"(82.55mm)
3 920207	MEC 8	1/2"(12.7mm)		1/2"(12.7mm)	1-5/16"(33.33mm)	1-7/16"(36.51mm)
920336	MEC 12	3/4"(19.05mm)		3/4"(19.05mm)	1-5/8"(41.27mm)	1-5/8"(41.27mm)

FEMALE THREADED BARBED HOSE FITTING

This fitting is also made of high strength glass-reinforced Marelon®.

Part No.	Model No.
901014	1/2"(12.7mm) FPT to 1/2"(12.7mm) HOSE BARB
901015	3/4"(19.05mm) FPT to 3/4"(19.05mm) HOSE BARB
905012	1-1/2"(38.1mm) FPT to 3/4"(19.85mm) HOSE BARB
905013	1-1/2"(38.1mm) FPT to 1"(24.4mm) HOSE BARB
905015	1-1/2"(38.1mm) FPT to 1-1/8"(28.57mm) HOSE BARB
905014	1-1/2"(38.1mm) FPT to 1-1/2"(38.1mm) HOSE BARB



VENTED LOOPS

Installing one of our vented loops will ensure that fluids will not siphon from tank to tank. Vented Loops are commonly used in the marine toilet system and engine cooling system. The simple valve system incorporated in the top of the loop allows air to enter the line when not in use, yet effectively seals as water or other fluid passes through. Molded in Marelon®, neither vent nor loop will corrode. The duckbill one way valve is designed to seal properly if particulate matter is present in fluids. The new MF-846 vent barb assembly option can be used in lieu of the standard MF-841 cap/duckbill. This option allows venting to the outside of the hull via a 1/4"(6.35mm) hose.

NEW White Color Available

Part No.	Model No.	Barb Size	Height	Width
903000	MF 840	1-1/2"(38.1mm)	5-1/4"(133.35mm)	7-3/4"(196.85mm)
903000W	MF 840 White	1-1/2"(38.1mm)	5-1/4"(133.35mm)	7-3/4"(196.85mm)
903001	MF 842	3/4"(19.05mm)	4-1/2"(114.3mm)	3-3/4"(95.25mm)
903001W	MF 842 White	3/4"(19.05mm)	4-1/2"(114.3mm)	3-3/4"(95.25mm)
903002	MF 841	Vent Cap Assembly		
903002W	MF 841 White	Vent Cap Assembly		
903003	MF-843	5/8"(15.87mm)	4-1/2"(114.3mm)	4"(101.6mm)
903004	MF-846	Vent Barb Assembly		
903007	MF-844	1"(25.4mm)	7"(177.8mm)	9"(228.6mm)
903007W	MF-844 White	1"(25.4mm)	7"(177.8mm)	9"(228.6mm)
903008	MF-845	1/2"(12.7mm)	5-1/4"(133.35mm)	4-1/4"(107.95mm)
903008W	MF-845 White	1/2"(12.7mm)	5-1/4"(133.35mm)	4-1/4"(107.95mm)
903009	MF-847	1-1/8"(28.57mm)	7"(177.8mm)	9"(228.6mm)
903009W	MF-847 White	1-1/8"(28.57mm)	7"(177.8mm)	9"(228.6mm)
903011	MF-839	1-1/4"(28.57mm)	7"(177.8mm)	9"(228.6mm)
903011W	MF-839 White	1-1/4"(28.57mm)	7"(177.8mm)	9"(228.6mm)

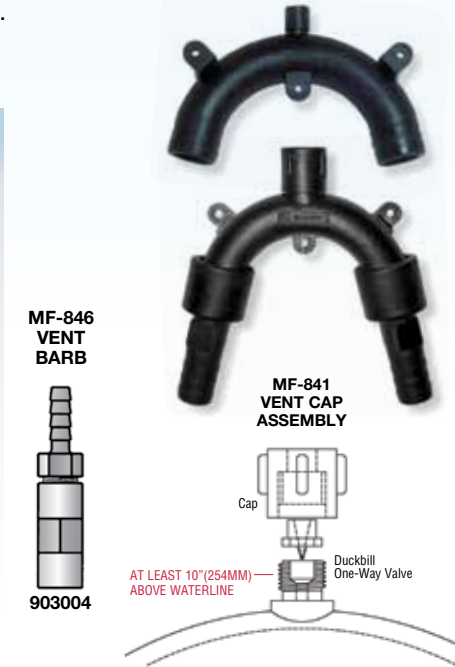

'Y' VALVES & CONNECTORS

Forespar® 'Y'-Valves and Connectors are molded from Marelon®. Offering an improved, stronger handle design, our valves are available in 1"(25.4mm) and 1-1/2"(38.1mm) barb size. 'Y'-Valves are an essential piece of equipment when the flow of water or other fluids are required to be conveniently diverted, as in a marine head application where a holding tank is utilized. They are easily mounted to a bulkhead. The valves are operated by a simple 120° movement. Positive stops are provided between positions. Replacement parts are available.

Our 'Y' Connectors can be used for connecting fluid lines. End plate may be removed for blockage relief etc. O-ring seal ensures leak free performance and is safe under pressure working conditions up to 40 P.S.I. Available with or without mounting flange.



'Y' CONNECTORS			
Part No.	Model No.	Flange	Barb Size
902002	HYCF 16	Yes	1"(25.4mm)
902003	HYC 16	No	1"(25.4mm)
902004	HYCF 24	Yes	1-1/2"(38.1mm)
902005	HYC 24	No	1-1/2"(38.1mm)

'Y' VALVES		
Part No.	Model No.	Barb Size
902000	MF 852	1-1/2"(38.1mm)
902001	MF 853	1"(25.4mm)
902006	'Y'-Valve Parts Kit (fits 1 & 1-1/2")	
902007	MF 854	3/4"(19.05mm)
902008	MF 855	1-1/8"(28.57mm)

IT IS NOT RECOMMENDED TO INSTALL Y-VALVES BELOW THE WATERLINE

FORESPAR'S® MARELON® INTEGRATED PLUMBING SYSTEM

Exceeding ABYC recommendations and meeting all UL standards; its unique design provides easy installation in a wide variety of valve configurations. It allows the OEM to design systems never before possible.

All Marelon® integrated valves are sold as a complete system. The assembly consists of thru-hull, valve body and tailpipe barb or female pipe thread end. The thru-hulls use a buttress style thread for exceptional strength and are not compatible with any other valves. Thru-hulls cannot be sold or used separately. All valves have one part number for the complete assembly. Each valve is factory assembled and pressure tested. Forespar® cannot be responsible for valves disassembled and modified or reassembled improperly.

In case of an emergency, all non-screened thru-hull style valves are supplied with a handle cap/bung that is designed to plug the thru-hull from the outside. This plug can be put in place while the vessel is in the water. The valve can then be removed from the king-nut and any blockage cleared. Warning – Never leave a boat unattended while bung is in place and valve is disassembled. This bung plug is for temporary use only. The bung can also be used during Winter storage to keep debris from collecting or insects from nesting inside thru-hull.

Per ABYC/UL requirements, a flat surface approximately the same diameter as the king-nut is needed inside the hull for proper installation. All valves are full port. The I.D. of the hose barb is carried thru the ball so there is no restriction of flow.

Temperature Range: -40° F to +176° F, -40° C to +80° C

ANTI-VENTURI T-HULL

Custom tooled by Forespar®, these new thru-hulls have been tested on boats at varying rpm's and turn rates up to 45 mph. On a 3/4" generator intake line with this thru hull fitted, 0" to ~5" of vacuum was noted. This did not present a pressure situation which could potentially push water past the vanes of an older impeller and flood the cylinders or starve it of cooling water. The unique notch and lowered ramp in the leading edge (photo #1-front) provides a force-feed effect. To keep this force from overwhelming equipment impellers, the exit slot (photo #2-back) allows water flow to exit at a controlled rate. Installed and tested by the Monterey Boats team of engineers.

The new Forespar® "Anti-Venturi" head thru hull for use with the 1/2" & 3/4" Marelon® Integrated Plumbing Systems seacocks ("93" series flange style valves) is available now in 3/4". These have the Integrated Plumbing Systems buttress style thread-form to fit the Integrated System flanged seacocks only. To order this option on any flanged style Marelon® integrated valve add a "V" after the valves 6 digit part number.



Part No.	Description
930171	Anti-Venturi T-Hull

ENGINE FLUSH OUT VALVE

Engines running in salt or brackish water need to be flushed with fresh water after use to prevent costly corrosion during Winter or off-season storage. Forespar® has designed a single valve system that makes this maintenance procedure simple.



This Seacock/Y Valve configuration includes a brass garden hose connection to facilitate regular fresh water engine flushing valve includes thru-hull that must be used. A quick and easy way to flush inboard engine systems... an often difficult maintenance task.

Diameter Screened	Mushroom	Mushroom
1"(25.14mm)	931274	937474
1-1/4"(31.75mm)	931275	937475
1-1/2"(38.1mm)	931276	937476
2"(50.8mm)	931278	937478

LOCKING HANDLE OPTION

Locking handle option for integrated Seacocks 1"(25.4mm) through 2"(50.8mm) sizes



Forespar offers an optional locking plate installed at the factory on any "93" series Integrated Seacocks. These new locking plates allow the handle to be set in the closed position and a pad-lock used to positively lock the valve closed. This new feature will satisfy the USCG requirements for locking overboard discharged head system seacocks in the closed, no discharge position.

Part No	Description
930136	Optional handle lock for 1"(25.4mm) & 1-1/4"(31.75mm)
930137	Optional handle lock for 1-1/2"(38.1mm) & 2"(50.8mm)
Note: - Forespar does not supply the padlock. Valve locks are not sold separately and are not a retrofit item.	

MARELON® INTEGRATED PLUMBING SYSTEMS HOSE BARB "93" SERIES

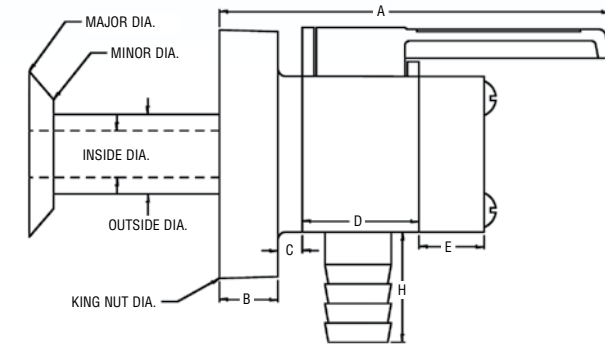
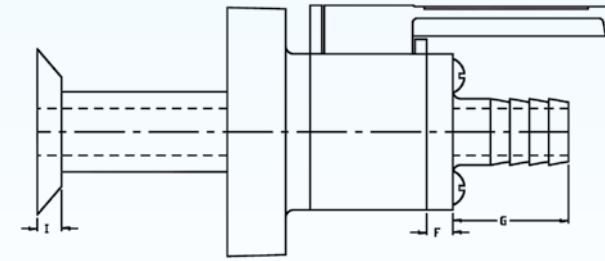

DIMENSION	1/2" & 3/4" (12.7mm)&(19.05mm)	1"25 & 1-1/4" (25.4mm)&(31.75mm)	1-1/2" & 2" (38.1mm)&(50.8mm)
MAJOR DIA.	1.73(43.94mm)	2.20(55.88mm)	2.79(70.86mm)
MINOR DIA.	1.28(32.51mm)	1.70(43.18mm)	2.18(55.37mm)
OUTSIDE DIA.	1.1(27.94mm)	1.6(40.64mm)	2.1(53.34mm)
INSIDE DIA.	.62(15.74mm)	1.05(26.67mm)	1.64(41.65mm)
KING NUT DIA.	3.13(79.50mm)	3.75(95.25mm)	4.21(106.93mm)
A	4.48(113.79mm)	6.19(157.22mm)	7.63(193.80mm)
B	.91(23.11mm)	.98(24.89mm)	1.10(27.94mm)
C	.48(12.19mm)	.31(7.84mm)	.23(5.84mm)
D	1.20(30.48mm)	1.87(47.49mm)	1.57(39.87mm)
E	.52(13.20mm)	.75(19.05mm)	1.35(34.29mm)
F	.53(13.46mm)	.75(19.05mm)	.78(34.29mm)
G	1.31(33.27mm)	1"=1.25 (25.4mm)=(31.75mm) 1-1/4"=1.50 (31.75mm)=(38.1mm)	1.50(38.1mm)
H	1.44(36.57mm)	1.50(38.1mm)	1.75(44.45mm)
I	.24(6.09mm)	.23(5.84mm)	.24(6.09mm)

ALL DIMENSIONS IN INCHES



Mushroom style thru-hull connectors also available with chrome plated head®

MARELON® THREADED VALVES

These valves are designed to meet the needs of builders and owners who require the benefits of the Marelon® integrated plumbing system, with female threads. This valve works great with A.N.P. Thru-Hulls. Forespar® offers this threaded valve in three of our most widely used configurations with N.P. T. or B.S.P threads.

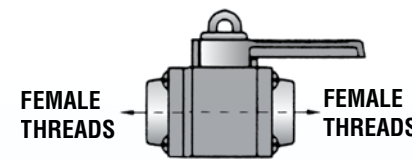

Valve P/N	Size
933332	1/2"(12.7mm)
933333	3/4"(19.05mm)
933334	1"(25.4mm)
933335	1-1/4"(31.75mm)
933336	1-1/2"(38.1mm)
933338	2"(50.8mm)

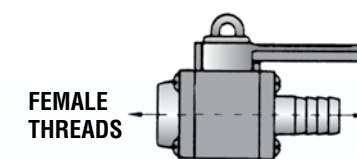

Valve P/N	Size
933342	1/2"(12.7mm)
933343	3/4"(19.05mm)
933344	1"(25.4mm)
933345	1-1/4"(31.75mm)
933346	1-1/2"(38.1mm)
933348	2"(50.8mm)

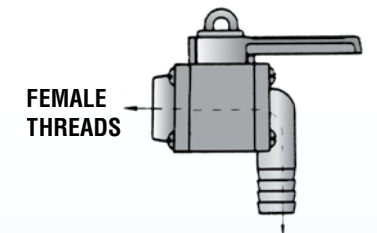

Valve P/N	Size
933352	1/2"(12.7mm)
933353	3/4"(19.05mm)
933354	1"(25.4mm)
933355	1-1/4"(31.75mm)
933356	1-1/2"(38.1mm)
933358	2"(50.8mm)

TECH TIPS FOR ONLINE TECH TIP ABOUT CHROME THRU-HULLS GO TO: www.forespar.com/techtips

MARELON® "93" SERIES OEM PLUMBING SYSTEMS

Original Equipment Manufacture - OEM SALES ONLY

FORESPAR® "93" SERIES OF VALVES AND THRU-HULL FITTINGS MEET ALL DESIGN CRITERIA AND EXCEED ALL MECHANICAL PROPERTY REQUIREMENTS SPECIFIED BY THE INTERNATIONAL STANDARDS ORGANIZATION (ISO 150/188) "SMALL CRAFT SEACOCKS AND THRU-HULL FITTINGS-PART 2: NON-METALLIC"



Arrows Indicate Water Flow Direction

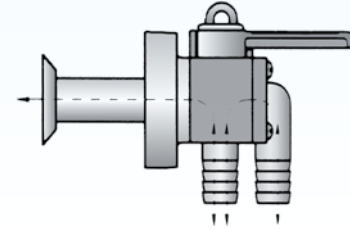

Mushroom Thru-Hull Size

931252 1/2"(12.7mm)
931253 3/4"(19.05mm)
931254 1"(25.4mm)
931255 1-1/4"(31.75mm)
931256 1-1/2"(38.1mm)
931258 2"(50.8mm)

Flush Thru-Hull Size

932252 1/2"(12.7mm)
932253 3/4"(19.05mm)
932254 1"(25.4mm)
932255 1-1/4"(31.75mm)
932256 1-1/2"(38.1mm)
932258 2"(50.8mm)

Mushroom Screened Thru-Hull Size

937452 1/2"(12.7mm)
937453 3/4"(19.05mm)
937454 1"(25.4mm)
937455 1-1/4"(31.75mm)
937456 1-1/2"(38.1mm)
937458 2"(50.8mm)

Flush Screened Thru-Hull Size

936452 1/2"(12.7mm)
936453 3/4"(19.05mm)
936454 1"(25.4mm)
936455 1-1/4"(31.75mm)
936456 1-1/2"(38.1mm)
936458 2"(50.8mm)

OEM SALES ONLY

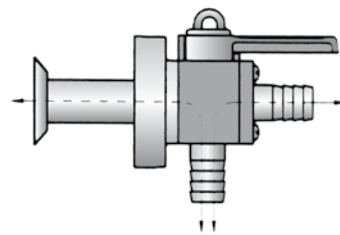

Mushroom Thru-Hull Size

931242 1/2"(12.7mm)
931243 3/4"(19.05mm)
931244 1"(25.4mm)
931245 1-1/4"(31.75mm)
931246 1-1/2"(38.1mm)
931248 2"(50.8mm)

Flush Thru-Hull Size

932242 1/2"(12.7mm)
932243 3/4"(19.05mm)
932244 1"(25.4mm)
932245 1-1/4"(31.75mm)
932246 1-1/2"(38.1mm)
932248 2"(50.8mm)

Mushroom Screened Thru-Hull Size

937442 1/2"(12.7mm)
937443 3/4"(19.05mm)
937444 1"(25.4mm)
937445 1-1/4"(31.75mm)
937446 1-1/2"(38.1mm)
937448 2"(50.8mm)

Flush Screened Thru-Hull Size

936442 1/2"(12.7mm)
936443 3/4"(19.05mm)
936444 1"(25.4mm)
936445 1-1/4"(31.75mm)
936446 1-1/2"(38.1mm)
936448 2"(50.8mm)

OEM SALES ONLY

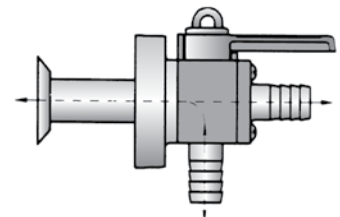

Mushroom Thru-Hull Size

931542 1/2"(12.7mm)
931543 3/4"(19.05mm)
931544 1"(25.4mm)
931545 1-1/4"(31.75mm)
931546 1-1/2"(38.1mm)
931548 2"(50.8mm)

Flush Thru-Hull Size

932542 1/2"(12.7mm)
932543 3/4"(19.05mm)
932544 1"(25.4mm)
932545 1-1/4"(31.75mm)
932546 1-1/2"(38.1mm)
932548 2"(50.8mm)

Mushroom Screened Thru-Hull Size

937642 1/2"(12.7mm)
937643 3/4"(19.05mm)
937644 1"(25.4mm)
937645 1-1/4"(31.75mm)
937646 1-1/2"(38.1mm)
937648 2"(50.8mm)

Flush Screened Thru-Hull Size

936642 1/2"(12.7mm)
936643 3/4"(19.05mm)
936644 1"(25.4mm)
936645 1-1/4"(31.75mm)
936646 1-1/2"(38.1mm)
936648 2"(50.8mm)

OEM SALES ONLY

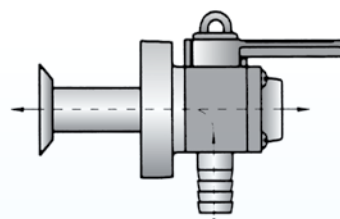

Mushroom Thru-Hull Size

931532 1/2"(12.7mm)
931533 3/4"(19.05mm)
931534 1"(25.4mm)
931535 1-1/4"(31.75mm)
931536 1-1/2"(38.1mm)
931538 2"(50.8mm)

Flush Thru-Hull Size

932532 1/2"(12.7mm)
932533 3/4"(19.05mm)
932534 1"(25.4mm)
932535 1-1/4"(31.75mm)
932536 1-1/2"(38.1mm)
932538 2"(50.8mm)

Mushroom Screened Thru-Hull Size

937632 1/2"(12.7mm)
937633 3/4"(19.05mm)
937634 1"(25.4mm)
937635 1-1/4"(31.75mm)
937636 1-1/2"(38.1mm)
937638 2"(50.8mm)

Flush Screened Thru-Hull Size

936632 1/2"(12.7mm)
936633 3/4"(19.05mm)
936634 1"(25.4mm)
936635 1-1/4"(31.75mm)
936636 1-1/2"(38.1mm)
936638 2"(50.8mm)

OEM SALES ONLY

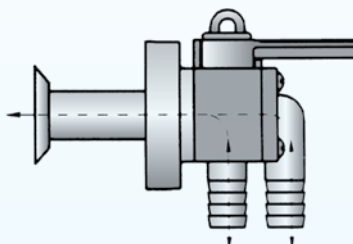

Mushroom Thru-Hull Size

931552 1/2"(12.7mm)
931553 3/4"(19.05mm)
931554 1"(25.4mm)
931555 1-1/4"(31.75mm)
931556 1-1/2"(38.1mm)
931558 2"(50.8mm)

Flush Thru-Hull Size

932552 1/2"(12.7mm)
932553 3/4"(19.05mm)
932554 1"(25.4mm)
932555 1-1/4"(31.75mm)
932556 1-1/2"(38.1mm)
932558 2"(50.8mm)

Mushroom Screened Thru-Hull Size

937652 1/2"(12.7mm)
937653 3/4"(19.05mm)
937654 1"(25.4mm)
937655 1-1/4"(31.75mm)
937656 1-1/2"(38.1mm)
937658 2"(50.8mm)

Flush Screened Thru-Hull Size

936652 1/2"(12.7mm)
936653 3/4"(19.05mm)
936654 1"(25.4mm)
936655 1-1/4"(31.75mm)
936656 1-1/2"(38.1mm)
936658 2"(50.8mm)

NOTE: All "93" Series Seacocks come standard with buttress thread thru-hulls

OPTIONAL THREADING - NPT or BSP Threaded Bases are available 3/4" to 2" for use with existing thru-hulls



Arrows Indicate Water Flow Direction

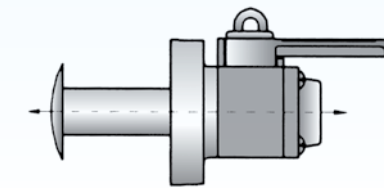

Mushroom Thru-Hull Size

931132 1/2"(12.7mm)
931133 3/4"(19.05mm)
931134 1"(25.4mm)
931135 1-1/4"(31.75mm)
931136 1-1/2"(38.1mm)
931138 2"(50.8mm)

Flush Thru-Hull Size

932132 1/2"(12.7mm)
932133 3/4"(19.05mm)
932134 1"(25.4mm)
932135 1-1/4"(31.75mm)
932136 1-1/2"(38.1mm)
932138 2"(50.8mm)

Mushroom Screened Thru-Hull Size

937332 1/2"(12.7mm)
937333 3/4"(19.05mm)
937334 1"(25.4mm)
937335 1-1/4"(31.75mm)
937336 1-1/2"(38.1mm)
937338 2"(50.8mm)

Flush Screened Thru-Hull Size

936332 1/2"(12.7mm)
936333 3/4"(19.05mm)
936334 1"(25.4mm)
936335 1-1/4"(31.75mm)
936336 1-1/2"(38.1mm)
936338 2"(50.8mm)

OEM SALES ONLY

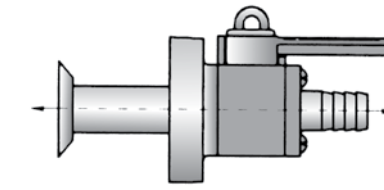

Mushroom Thru-Hull Size

931142 1/2"(12.7mm)
931143 3/4"(19.05mm)
931144 1"(25.4mm)
931145 1-1/4"(31.75mm)
931146 1-1/2"(38.1mm)
931148 2"(50.8mm)

Flush Thru-Hull Size

932142 1/2"(12.7mm)
932143 3/4"(19.05mm)
932144 1"(25.4mm)
932145 1-1/4"(31.75mm)
932146 1-1/2"(38.1mm)
932148 2"(50.8mm)

Mushroom Screened Thru-Hull Size

937342 1/2"(12.7mm)
937343 3/4"(19.05mm)
937344 1"(25.4mm)
937345 1-1/4"(31.75mm)
937346 1-1/2"(38.1mm)
937348 2"(50.8mm)

Flush Screened Thru-Hull Size

936342 1/2"(12.7mm)
936343 3/4"(19.05mm)
936344 1"(25.4mm)
936345 1-1/4"(31.75mm)
936346 1-1/2"(38.1mm)
936348 2"(50.8mm)

OEM SALES ONLY

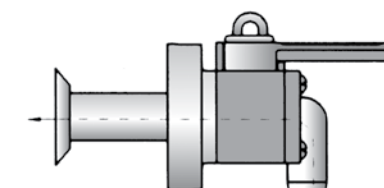

Mushroom Thru-Hull Size

931152 1/2"(12.7mm)
931153 3/4"(19.05mm)
931154 1"(25.4mm)
931155 1-1/4"(31.75mm)
931156 1-1/2"(38.1mm)
931158 2"(50.8mm)

Flush Thru-Hull Size

932152 1/2"(12.7mm)
932153 3/4"(19.05mm)
932154 1"(25.4mm)
932155 1-1/4"(31.75mm)
932156 1-1/2"(38.1mm)
932158 2"(50.8mm)

Mushroom Screened Thru-Hull Size

937352 1/2"(12.7mm)
937353 3/4"(19.05mm)
937354 1"(25.4mm)
937355 1-1/4"(31.75mm)
937356 1-1/2"(38.1mm)
937358 2"(50.8mm)

Flush Screened Thru-Hull Size

936352 1/2"(12.7mm)
936353 3/4"(19.05mm)
936354 1"(25.4mm)
936355 1-1/4"(31.75mm)
936356 1-1/2"(38.1mm)
936358 2"(50.8mm)

OEM SALES ONLY

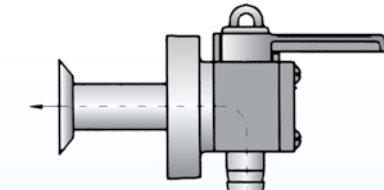

Mushroom Thru-Hull Size

931262 1/2"(12.7mm)
931263 3/4"(19.05mm)
931264 1"(25.4mm)
931265 1-1/4"(31.75mm)
931266 1-1/2"(38.1mm)
931268 2"(50.8mm)

Flush Thru-Hull Size

932262 1/2"(12.7mm)
932263 3/4"(19.05mm)
932264 1"(25.4mm)
932265 1-1/4"(31.75mm)
932266 1-1/2"(38.1mm)
932268 2"(50.8mm)

Mushroom Screened Thru-Hull Size

937462 1/2"(12.7mm)
937463 3/4"(19.05mm)
937464 1"(25.4mm)
937465 1-1/4"(31.75mm)
937466 1-1/2"(38.1mm)
937468 2"(50.8mm)

Flush Screened Thru-Hull Size

936462 1/2"(12.7mm)
936463 3/4"(19.05mm)
936464 1"(25.4mm)
936465 1-1/4"(31.75mm)
936466 1-1/2"(38.1mm)
936468 2"(50.8mm)

OEM SALES ONLY

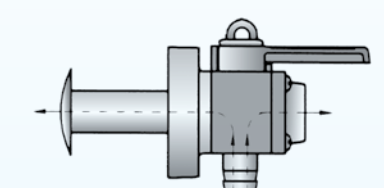

Mushroom Thru-Hull Size

931232 1/2"(12.7mm)
931233 3/4"(19.05mm)
931234 1"(25.4mm)
931235 1-1/4"(31.75mm)
931236 1-1/2"(38.1mm)
931238 2"(50.8mm)

Flush Thru-Hull Size

932232 1/2"(12.7mm)
932233 3/4"(19.05mm)
932234 1"(25.4mm)
932235 1-1/4"(31.75mm)
932236 1-1/2"(38.1mm)
932238 2"(50.8mm)

Mushroom Screened Thru-Hull Size

937432 1/2"(12.7mm)
937433 3/4"(19.05mm)
937434 1"(25.4mm)
937435 1-1/4"(31.75mm)
937436 1-1/2"(38.1mm)
937438 2"(50.8mm)

Flush Screened Thru-Hull Size

936432 1/2"(12.7mm)
936433 3/4"(19.05mm)
936434 1"(25.4mm)
936435 1-1/4"(31.75mm)
936436 1-1/2"(38.1mm)
936438 2"(50.8mm)

SINK WASTES

Available in straight and 90° configurations, these drains are designed for 1" and 3/4" tubing. Models SW-3, SW-4 and SW-6 are bright chrome plated, non-corrosive plastic.



SW-1



SW-2



SW-3



SW-4



SW-6

Part No.	Model No.	Tail	Flange	Cut-Out
907000	SW-1	Straight—For 1"(25.14mm) I.D.	1-3/4"(44.45mm)	1-5/16"(33.33mm)
907014	SW-2	90°—For 1"(25.14mm)I.D.	1-3/4"(44.45mm)	1-5/16"(33.33mm)
907015	SW-3	Straight—1-1/2"(38.11mm) screw	2-7/8"(73.02mm)	2"(50.8mm)
907016		Replacement Sink Stopper		
907017	SW-4	90° - For 1"(25.14mm) I.D.	2-7/8"(73.02mm)	2"(50.8mm)
907013	SW-5	(same as SW-1, for 3/4"(19.05mm)I.D.)	1-3/4"(44.45mm)	1-5/16"(33.33mm)
907022	SW-6	Straight—For 1"(25.14mm)I.D.	2-7/8"(73.02mm)	2"(50.8mm)
907027	SW-7	(same as SW-6, for 3/4"(19.05mm) I.D.)	2-7/8"(73.02mm)	2"(50.8mm)

TANK VENT

A new idea in fuel tank vents. For hulls with solid cores only. Unit press-fits into 3/4"(19.5mm) hole without the need of a nut. The stainless steel screen will not corrode and has no plating to chip.

Part No.	Model No.
907029	MF 610

Tank Vent Installation

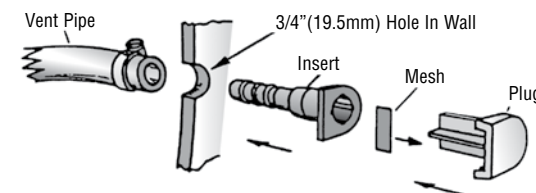

For 5/8"(15.87mm) hose.



UTILITY DRAIN D-1

Fully threaded acetal utility drain.
Thread length: 1-3/8"(34.92mm)
Thread size: 1"(25.14mm)

Part No.	Model No.
907028	D-1

DECK FILLS

Molded in Marelon® for lifetime durability, Forespar® Deck fills are available in three color-coded models. Each clearly marked for use with either water, fuel or waste. Easy-open cap is fitted with nylon retainer cord and rubber 'O'-ring to ensure a safe and efficient seal. Suitable for 1-1/2"(38.1mm) I.D. hose.

Part No.	Model No.	For use with:
907002	MF 830 F	Fuel
907003	MF 830 W	Water
907004	MF 830 WST	Waste
153000		Waste Adapter for 1.5"(38.1mm) threads



Deck Flange is 4"(101.6mm) dia.
Cutout: 2-1/8"(53.97mm).
Hose Barb Length: 3"(76.2mm).

GARBOARD DRAINS

For newer, thicker transoms, Forespar® designed a drain & plug assembly to fit up to 1-3/4"(44.45mm) thick transoms. Our Marelon® female 3/4"(19.05mm) elbows or female threaded barbed hose fitting (see page 40) can be screwed onto the end for hose attachment if needed. All Marelon® construction insures years of corrosion free use.

Part No.	Description
906081	GARBOARD DRAIN
906075	GARBOARD DRAIN (Short)
906076	GARBOARD DRAIN (Long)
906091	NEW GARBOARD DRAIN Black 2" dia.
906092	NEW GARBOARD DRAIN White 2" dia.



- GD-S #906075 (short) Usable length with 5 threads engaged is 2-1/2" (63.5mm) maximum, 1-7/16" (36.51mm) minimum.
- GD-L #906076 (long) Usable length with 5 threads engaged is 3-1/4" (82.55mm) maximum, 2-1/2" (63.5mm) minimum.
- Diameter of the flange (both ends) is 2" (50.8mm). Diameter of the body (female threaded unit) is 1-3/16" (30.16mm). This is the diameter of the hole needed to install the unit through the transom.
- The screw style plug with gasket comes with it standard. Color of the Marelon material is white (like all our T-hulls).

SAFE-T-PLUG™ GARBOARD DRAIN

If you have ever forgotten to put the drain plug in when launching your boat, you'll appreciate the new Forespar Safe-T-Plug™. Using a flotation ball system, it automatically seals itself when the transom hits the water preventing accidental flooding. The ball seal cartridge can also be easily removed to clean the stainless screen by unthreading the seal insert using the head of the plug cap.

Head Flange 2" (50.8 mm) round x 1-1/2" (38.1 mm) oval
Depth of Bury 2" (50.8 mm)
Diameter of Bury 15/16" (23.81 mm)

Part No.	Model No.
920095	Plastic Oval
920096	Plastic Round
920097	Brass Round
920098	Brass/Chrome Round



OUTBOARD WELL DRAIN

The Forespar® outboard well drain offers a corrosion proof, easy-to-install replacement for the old fashioned brass fitting. Can also be used as a chafe guard to lead hose, wiring, steering cables, etc. through bulkheads, floor timbers and fiberglass panels. Barbs on O.D. ensure positive locking action. Designed to fit 1"(25.14mm) diameter hole.

Flange is 1-1/4"(31.75mm) dia.

Part No.	Model No.
907006	MF 795



DRAIN PLUG

Molded from Forespar's Marelon® and fitted with a neoprene seal; the Forespar® Drain Plug is carefully designed to not deteriorate and crack with age.

Part No.	Model No.
907001	MF 790



WATER STRAINER

This water strainer is made of Marelon® (same material as our valves). It features a new universal mounting bracket and clear polycarbonate lid for ready inspection. The stainless steel strainer basket can be easily removed for cleaning. Intake and exit ports are 1-1/2"(38.1mm) ANP threads standard. Reducers for 3/4"(19.05mm) I.D. hose are available separately. Diameter: 6.3"(160.02mm) Height: 6.1"(154.94mm). The flow rate is 40 GPM(151.41l/m) with 1-1/2"(38.1mm) ports.

(SEE REDUCERS AND ADAPTERS SHOWN ON THIS PAGE)

The new mounting bracket allows the strainer exit port to be positioned in the proper direction by simply loosening the bracket clamp and rotating the entire housing. This will allow the OEM or aftermarket customer greater flexibility in installation.



Part No.	Model No./Description
906066	MF 810 Water Strainer
906067	MF 811 Gasket Set
906065	s/s Basket only
920178	Clear Cover only

WATER STRAINER REDUCERS/ADAPTERS



Part No.	Model No.	Thread
901045	FTC 8	1/2"(12.7mm) female
901046	FTC 12	3/4"(19.05mm) female
901042	FTC 16	1"(25.14mm) female
901044	FTC 20	1-1/4"(31.75mm) female
901043	FTC 24	1-1/2"(38.1mm) female
901040	MTC 12-8	3/4"(19.05mm)-1/2"(12.7mm) male
901050	MTC 12-12	3/4"(19.05mm)-3/4"(19.05mm) male
901051	MTC 16-12	1"(25.14mm)-3/4"(19.05mm) male
901047	MTC 24-16	1-1/2"(38.1mm)-1"(25.14mm) male
901048	MTC 24-20	1-1/2"(38.1mm)-1-1/4"(31.75mm) male
901049	MTC 24-24	1-1/2"(38.1mm)-1-1/2"(38.1mm) male
910062	RB 24-16	1-1/2"(38.1mm) male- 1"(25.14mm) female
910063	RB 24-12	1-1/2"(38.1mm) male -3/4"(19.05mm) female

FLOWTECH™ PERFORMANCE VALVE THE RACER'S CHOICE

Flowtech™ free flow sea valves incorporate the valve body, thru-hull and the choice of all three sizes of hose pipe connections all in one set. These high performance valves are available for 3/4"(19.05mm), 1"(25.14mm) & 1-1/2"(38.1mm) hose sizes. The Flowtech™ valve pipe can be faired smooth to the boat's outer skin so that when the valve is closed, the internal plunger and valve pipe creates a flush, fair & fast outer surface. Made of Marelon®

(Original Equipment Manufacturer SALES ONLY)

VALVE COMPONENTS ARE NOT COMPATIBLE WITH ANY OTHER MANUFACTURERS' PRODUCT

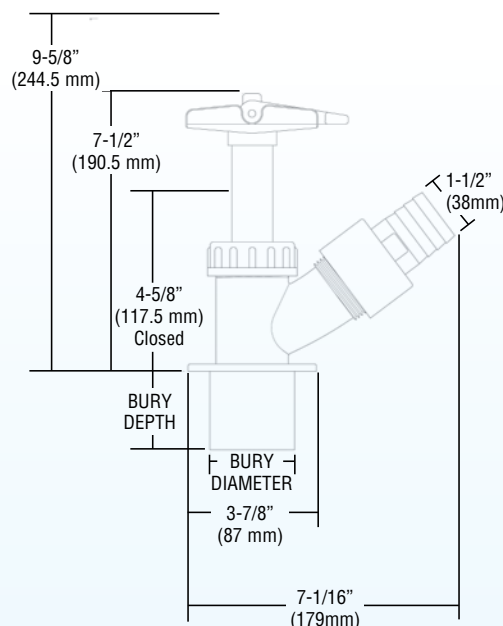

Volvo 60 Flowtech™ Installation



Description	P/N	Wt
Folwtech™ Valve Mark I	905106	1.502 oz
Folwtech™ Valve Mark II	905109	1.702 oz

Bury Info	Depth	Dia.
Folwtech™ Valve Mark I	1 3/8" (35 mm)	1 7/8" (47.6 mm)
Folwtech™ Valve Mark II	2 1/16" (52 mm)	2 1/4" (57 mm)

REPLACEMENT PARTS

AWNING POLES

For TAP 3-6, TAP 4-8, 6-12, 5-10 HD and 6-12 HD
Part No. Model No./Description
 504003 End Kit

MAST CARS

AT-125-S/T-125-S
Part No. Model No./Description
 333010 Toggle/Knuckle assembly
 331013 Plastic Runners
 333000 Shackles

FC-125/FC-125-SP

Part No. Model No./Description
 332003 FC Flange only
 332005 Hinge Pin
 331013 Plastic Runners

DECK CHOCKS

Part No. Model No./Description
 332007 DC-2 Spool replacement spool only
 300005 DC-TS Post replacement post only

DECK FILLS

Part No. Model No./Description
 907024 Red Fuel Cap
 907025 Blue Water Cap
 907026 Black Waste Cap

SPINNAKER POLES

For EL-150 thru EL-300-EF
Part No. Model No./Description
 408025 Repair Kit

For XP-200 thru XP-450-EF

Part No. Model No./Description
 309080 Repair Kit

For TR-200 thru TR-450-EF

Part No. Model No./Description
 309049 Repair Kit

For TS-300 thru TS-450

Part No. Model No./Description
 309050 Repair Kit

MAST LIGHTS

ML-1
Part No. Description
 132009 Replacement Lens ring (new)
 132035 Bottom Bulb Assy.

ML-2

Part No. Description
 132009 Replacement Lens ring (new)
 132025 WN 211 Top Bulb
 132035 Bottom Bulb Assy.
 132041 Top Lens and Cap Assy.

RAILFAST®

Part No. Description
 002066 Screw 3/8"
 156050 Base-Fiberglass
 156052 Bracket strap
 156053 Pin-square
 156055 Bracket shim-7/8"
 156056 Allen wrench
 156058 Boss cover

WHISKER POLES

ADJ 4-8
Part No. Model No./Description
 300026 Repair Kit
 400006 Lock Repair Kit
 404010 7/8" inner tube w/ lock
 504002 1" outer tube

ADJ 6-12

Part No. Model No./Description
 300027 Repair Kit
 400008 Lock Repair Kit
 406015 1 1/8" inner tube w/ lock
 406001 1 1/4" outer tube

HD 6-12 DL

Part No. Model No./Description
 304015 UEF-3 special inboard end
 304018 UEF-5 outboard end
 400009 Lock Repair Kit
 406211 1 3/4" inner tube w/ lock
 406202 1 7/8" outer tube

ADJ 7-17 DL

Part No. Model No./Description
 304018 UEF-5 outboard end
 304057 UEF-3 inboard end
 400010 Lock Repair Kit
 407007 1 3/4" inner tube w/ lock
 407008 1 7/8" middle tube w/ lock
 406210 2" outer tube

CARGO MATE™

Part No. Description
 153230 Deck Flange
 153204 Base Mount
 153207 33" extension
 153232 Plug for Deck Mount
 153233 Transom Ring Mount (Power)
 153209 Storage Bag

MOTOR MATE™

Part No. Description
 153104 Base Mount
 153105 Rail Mount
 153107 Bottom Tube only
 153109 Vinyl Bag

Nova Lift™

Part No. Description
 153366A Upper Arm Assembly
 152250A Lower Mount Tube Assembly

THRU-HULL PARTS

Part No. Description
 907007 CF 249 1/2" nut only
 907008 CF 249 3/4" nut only
 907009 CF 249 1" nut only
 907010 CF 249 1 1/4" nut only
 907011 CF 249 1 1/2" nut only
 907012 CF 249 2" nut only
 403125 Small Mold Plug (OEM only)
 403135 Large Mold Plug (OEM only)

MARELON® PLUMBING SYSTEM PARTS

Part No. Description
 930072 Cap/Plug/Bung
 930073 Cap/Plug/Bung
 930074 Cap/Plug/Bung

LINE CONTROL™ WHISKER POLES

Replacement Inboard Ends
 LC 8-14
Part No. Model No./Description
 408041 EL-200-LC EF
 LC 10-18
Part No. Model No./Description
 401035 EL-250-LC EF
 LC 12-22
Part No. Model No./Description
 402037 EL-300-LC EF
 304038 Ultra Collar

LC 13-24
Part No. Model No./Description
 403104 LCC-1 Collar

LC 15-27
Part No. Model No./Description
 405102 LCC-2 Collar

TILLER EXTENSIONS

Part No. Description
 104004 TFP - Assembly Complete w/ Socket
 104006 TFP - Socket (Receptacle) Only

ULTRA END FITTINGS

Part No. Description
 304029 UXP - Repair Kit
 304030 UTR 200 & 250- Repair Kit
 304031 UTR 300 & 350- Repair Kit

SAFETY GEAR

OP-120, OPST-120 Overboard Poles
Part No. Model No./Description
 202026 Flag
 202132 Stainless Steel Clip
 202020 Replacement Top Half With Flag



FORESPAR®

MARINE PRODUCTS THAT PERFORM

OVERSEAS AGENTS AND DEALERS

AUSTRALIA

DeckHardware Marine Solutions
F5 122-126 Old Pittwater Rd
Brookvale NSW 2100
Tel: 61 (0) 2 9905 9400
Fax: 61 (0) 2 9905 9455
www.deckhardware.com.au
email: sales@deckhardware.com.au

AUSTRIA

ALLTECKNIK-ALLROUNDMARIN
Griesfeldstrasse 1
A-2351 Wiener Neudorf, Austria
Ph: (43) 02236-64676
Fax: (43) 02236-63135
email: a.rigal@allroundmarin.com

BRAZIL

REGATTA
R. Alvarenga, 2121
Butanta, Sao Paulo-SP
Brazil
Ph: (55) 1130303400
Fax: (55) 1138147015
email: thalita@regatta.com.br

CARIBBEAN

F.K.G. MARINE RIGGING
Box 5011 Phillipsburg
37 Wellington Road, Cole Bay
St. Maarten, Netherland Antilles
Ph: (5995) 44732
Fax: (5995) 42171
email: kevin@fkg-marine-rigging.com

BUDGET MARINE - N.A. (Main Office)

25 B Waterfront Road, Cole Bay
St. Maarten, Netherland Antilles
Ph: 599-544-3134
Fax: 599-544-4409
email: sales@budmar.an

BUDGET MARINE - ANTIGUA

Jolly Harbour Boatyard
Bolans, Antigua, West Indies
Ph: 268-462-8753
Fax: 268-462-7727
email: sales@budmar.ag

BUDGET MARINE - BONAIRE

Kaya Carlos A. Nicolaas 4
Kralendijk, Bonaire, Netherland Antilles
Ph: 599-717-3710
Fax: 599-717-3523
email: peter@budgetmarinebonaire.com

BUDGET MARINE - GRENADA

L'Anse aux Epines
Prickly Bay, St. Georges, Granada
Ph: 473-439-1983
Fax: 473-439-2037
email: budmarGD@caribsurf.com

BUDGET MARINE - ST. MARTIN

L'ile Marine
Sandy Ground Bridge
Rue Lady Fish
Saint Martin, F.W.I.
Ph: 590-290860
Fax: 590-290896
email: l.ile.marine@wanadoo.fr

BUDGET MARINE - ST. THOMAS, U.S.V.I.

Vitraco Park P.O. Box 7937
St. Thomas, U.S.V.I. 00801
Ph: 340-774-2667
Fax: 340-774-2667
email: budmarsl@islands.vi

BUDGET MARINE - TRINIDAD

Western Main Road
Chaguaramas, Trinidad, West Indies
Ph: 868-634-2006
Fax: 868-634-4382
email: sales@budmar.co.tt

CHINA

Aegis Marine International Inc.
W501, No. 4 Cheng Kung 2nd Road
Kaohsiung, Taiwan
Ph: (07) 823-2398
Fax: (07) 823-1258
email: info@mmimarine.com

Aegis Marine International Inc.

898 West 16th Street
Newport Beach, Ca. 92663
Ph: 949-631-3014
Fax: 949-631-0313
email: info@mmimarine.com

ENGLAND

AQUAFAX
14 Dencora Way
Sunson Park, Luton, Beds, LU3-3HP
United Kingdom
Ph: (44) 0582-581222
Fax: (44) 0582-580558
email: sales@aquafax.co.uk

AQUAFAX LTD.

14 Dencora Way
Sundon Business Park
Luton
Beds. LU3 3HP
Tel: 01582 568700
Fax: 01582 568720
email: sales@aquafax.co.uk

AQUAFAX LTD. (HAMBLE)

12 -13 Mitchell Point
Ensign Business Park
Hamble
Hants. SO31 4RF
Tel: 023 8045 7206
Fax: 023 8045 7208

AQUAFAX LTD. (MIDDLEWICH)

11 Valley Court, Sanderson Way
Midpoint 18, Pochin Way
Middlewich
Cheshire. CW10 0GF
Tel: 01606 841111
Fax: 01606 841188

AQUAFAX LTD. (WROXHAM)

Unit 31, Littlewood Lane
Stalham Road Industrial Estate
Hoveton
Norfolk. NR12 8DZ
Tel: 01603 781881
Fax: 01603 781981

AQUAFAX LTD. (PLYMOUTH)

Unit 5 Plymouth Trade Park
22 Macadam Rd
Plymouth. PL4 0RU
Tel: 01752 669944
Fax: 01752 667764
e-mail: sales@aquafax.co.uk
website: www.aquafax.co.uk

INTERNATIONAL MARINE PRODUCTS

RO24 3-4 Jarman Way
Royston Hertfordshire SG8 5FE
United Kingdom
Ph: (44) 01763 241300
Fax: (44) 01763 241770
email: sales@improducts.co.uk
DDI: 01763 252402
Skype: Susannah Ralston
Web Site: www.improducts.co.uk

EGYPT

MAPSO
P.O. Box 2643
44 Industrial Zone,
Cairo-Ismaillia Desert Rd
Cairo, 11769 Egypt
Ph: +202 2698 4777
Fax: +202 2699 0780
Email: aymanraafat@mapso.com
Web Site: www.mapso.com

FRANCE

SVENDEN'S INTERNATIONAL DIST.
C/O Jean-Michel Bernasconi
2029 Route du Bouchet
74400 Chamonix-Mont-Blanc
France
Ph: (33) 04 50 55 80 41
Fax: (33) 04 50 55 80 41
email: export@svendsens.com

GERMANY

SAILTEC VERTRIEBS GmbH
Hasselbinnen 28
D-22869 Schenefeld Bei
Hamburg
Germany
Ph: +49 40 8229940
Fax: +49 40 8304279
email: info@sailtec.de

GREECE

TECREP
38 Akti Moutsopoulou 185
36 Piraeus
Greece
Ph: +39 (0)10 9761106
Fax: (30) 1-418-4280
email: tecrep@acropolis.net

ITALY

TOMASONI FITTINGS SRL
Via G. Marconi 59
16010 Savignone (GE)
Italy
Ph: +39 (0)10 9761106
Fax: +39 (0)10 9769470
email: info@tomasoni.it

JAPAN

INDUSTRIAL SUPPLIERS CO., LTD.
NAC Minato Building 2F,
2-1-24 Kaigan, Minato ku,
Tokyo, Japan 105-0022
Tel: 81 3 5443 8231
Fax: 81 3 5443-8240
sales@isco.co.jp

NETHERLANDS

BELSHIP
Krommewetering 61A
3543 AM - Utrecht
Netherlands
Ph: 0031 (0)30 240 8040
Fax: 0031 (0)30 240 8041
email: team@belship.nl

NEW ZEALAND

KZ MARINE (SAIL)
39 Vesty Drive
Mt. Wellington, Auckland
New Zealand
Ph: (64) 9 573-1939
Fax: (64) 9 573-1959
email: rick@kzmarine.co.nz

NEW ZEALAND

Lighthouse Marine Equipment Ltd.
8c Tawa Drive
Albany Auckland, 0632
New Zealand
Ph: (64) 9 448-2761
Email: Mike@lhmarine.co.nz
Website: www.lhmarine.co.nz

NORWAY

NORWAY MARINE SUPPLY
Aasbievein 11
N488 Arendal
Norway
Ph: +47 37000370
Fax: +47 38701274
Email: supply@maritim.no
Web Site: www.maritim.no

SO. AFRICA

CENTRAL BOATING
85 Bree Street
Cape Town 8001
South Africa
Ph: (27) 021-24-8026
Fax: (27) 021-24-2564
email: david@centralboating.co.za

SPAIN

TACK-VELAS
Pg. Joan de Borbo, 92 Local 9
08003 Barcelona
Spain
Ph: (34) 93-221-8212
Fax: (34) 93-221-8950
email: tackvelas@telefonica.net

SWEDEN

BENN'S MAST & RIGGING
Prastkragens Vag 20
13245 Saltjo-Boo
Sweden
Ph: (46) 8 668-6853
Fax: (46) 8 663-9894
email: pia@benns.se

EGNELL TRADING AB

Ulrikagatan 5
SE-115 23 Stockholm
Tel: +46 8 6639370;
Cell ph: +46 707 525155
email: pia@egnelltrading.se

TAIWAN

ING-HAI
Room 508 # 9, Lane 83
Chung Shan North Road, Sec. 1
Taipei, Taiwan, R.O.C.
Ph: (886) 2 25312088
Fax: (886) 2 25236531
email: inghai@tpts6.seed.net.tw

TURKEY

MARINE EFFECTS
Postane Mh.Belde 2 Sit. Hulya Sk.
No:20/7
Tuzla 34940, Istanbul
Turkey
Ph: +90 216 447 0962
Fax: +90 216 447 3363
email: alkingulcan@marineeffects.com
Web site www.marineeffects.com

Forespar, forespar.com, Cargo Mate, Hoyt Boom, Hoyt Jib Boom, LanoCote, Leisure Furl, Lightning Master, Line Control, Marelon, MareLube, Mini-Galley, Motor Mate, Nash Labels, Nova Davit, Nova EZ-Board, Nova Lift, OceanRacer, Radar Spar, Railfast, ReFresh, Roll-X, Safe-T-Plug, Sail Saver, Smart Valve, Smart Valve ROV, Spectra, StaFAST, TEF 45, Tri-Reacher, Ultra Series, Yacht Rod and words marked with a © or ™ symbol and other Forespar.com graphics, logos, page headers, button icons, scripts, and service names are trademarks, registered trademarks or trade dress of Forespar in the U.S. and/or other countries. Forespar's trademarks and trade dress may not be used in connection with any product or service that is not Forespar's, in any manner that is likely to cause confusion among customers, or in any manner that disparages or discredits Forespar. All other trademarks not owned by Forespar that appear in this catalog are the property of their respective owners, who may or may not be affiliated with, connected to, or sponsored by Forespar.

FORESPAR® PRODUCTS POLICIES & CONTACTS

QUALITY COMPONENTS

Whatever you order, you'll receive more for your money from Forespar®. For example, we only use Spectron 12® composite line on our bridles and heavy duty vinyl on our lanyard wire, not the thin coated type for sailmakers. Our castings are prime type 356 aluminum alloy, heat treated to T-6 condition for strength and a higher coefficient of elongation. This means a reduction in brittleness without reducing the heat treated strength.

SUPERIOR ANODIZING

The clear anodizing used on our tubing meets military specifications, which means approximately three times the coating thickness of "commercial" grade anodizing. Our end fittings, where corrosion resistance is particularly important, are carefully machined, extensively deburred and then finished with a high quality, hard coat finish of 2 mil. minimum thickness anodizing. Our fittings are not dyed painted or stained to cover up lesser quality, and we invite you to compare Forespar® fittings with those of any other manufacturer.

ORDERING OPTIONS

IMPORTANT - There are three distinct ways to order our spinnaker poles, reaching struts and jib booms.

1. CUSTOMIZED: Poles may be ordered to the specific length required for your boat. Simply specify our Model No. and the exact overall length required.

2. "KIT" FORM: Everything for a complete pole job is included in our "Kit" packages. The tubing is supplied in the maximum length recommended for the particular diameter ordered. One end fitting is left unfastened so that the tubing can be cut to length, before final customizing. By keeping an inventory of kit poles, you can quickly and easily customize them to whatever length your customer requires. This eliminates "single item" freight costs and keeps your customer happy with fast immediate service.

3. FITTINGS AND TUBING: If you have the know how, and the simple tools necessary, you can order the component parts and save money by doing the assembly yourself. Simply specify the model numbers of the end fittings and tubing sizes required.

PACKING

Every boom or strut is individually packed in its own shipping container for maximum protection and a "new" look when it arrives at its destination. Multi-packed items are protected by individual polyethylene bags.

CONTACTS

PHONE: 949.858-8820
FAX: 949.858-0505
WEBSITE: www.forespar.com
EMAILS

Customer Service: sales@forespar.com
Spar Division: alanm@forespar.com
Spar Engineering: schetelat@forespar.com
peterh@forespar.com

Forespar® is a registered trademark of Forespar Products Corporation.
Product pricing, design and specifications subject to change without notice.

Catalog Design by Broad Reach Marketing (414) 719-5368

RETURNED MERCHANDISE

No returns will be accepted without prior agreement from Forespar® including instructions on method of shipment and return authorization number. Customized merchandise is not returnable. Any unused, undamaged merchandise accepted for return will be subject to a 20% return and handling charge.

REPAIRS

Repairs necessary due to accident, misuse or normal wear and tear, will be made at customers request. Charges for such repairs will include published price of replacement parts and reasonable labor costs. All merchandise being returned for repair must be shipped prepaid and include return address and repair instructions.

A Return Authorization Number from our Customer Service department is required.

LIMITED WARRANTY

1 Forespar Products Corp. warrants all products manufactured by it to be free from defects in material and workmanship under normal use and with normal maintenance for a period of thirty six (36) months from the date of initial retail sale*. The Limited Warranty is extended only to the original retail purchaser and does not run to any subsequent purchaser. Proof of purchase is required.

2 It is a condition of this Limited Warranty that the product has been given reasonable care, and that damage has not resulted from improper installation, accident, negligence, misuse including undersized for performance required or from unauthorized alterations.

3 All claims under this Limited Warranty must be made directly to Forespar Products Corp. at the address set forth within thirty (30) days after discovery of the defect. Forespar Products Corp. may require any product to be returned to its factory for examination, transportation charges prepaid.

4 The obligations of Forespar Products Corp. under this Limited Warranty are limited to repairing or replacing such products which shall be determined by Forespar Products Corp. to have been defective in materials or workmanship. Forespar Products Corp. does not under any circumstances assume responsibility for any incidental or consequential damages incurred in connection with the use of its products.

5 Forespar Products Corp. reserves the right to improve its products through changes in design and material without incurring any obligation to incorporate such changes in products already completed or in the hands of purchasers.

6 **EXCLUSION OF WARRANTIES:** This Limited Warranty is in lieu of all other express Warranties, and shall expire thirty six (36) months from the date of initial retail sale. Any implied Warranty, including the Warranty of Merchantability and fitness for a particular purpose, is limited to the duration of this Limited Warranty.

7 Some states do allow limitations on how long an implied Warranty lasts or the exclusion of incidental or consequential damages, so the above limitations or exclusion may not apply to you. This Warranty gives you specific legal rights and you may also have other rights which vary from state to state.

8 The following items are excluded from this warranty: Spar Systems and Electrical Bulbs (mast lights & strobe lights).

*Some products are subject to limitation of warranty duration and/are so identified in the product description.



Forespar Corporate Headquarters



FORESPAR®

MARINE PRODUCTS THAT PERFORM

22322 Gilberto, Rancho Santa Margarita, CA 92688 - USA
Ph: 949.858.8820 • www.forespars.com

Catalog Price
\$2.00